

This document is not an API Standard; it is under consideration within an API technical committee but has not received all approvals required to become an API Standard. It shall not be reproduced or circulated or quoted, in whole or in part, outside of API committee activities except with the approval of the Chairman of the committee having jurisdiction and staff of the API Standards Dept. Copyright API. All rights reserved.

Instructions to Voters/Comments on API 520 Part II Ballot – “Shoulds and Shalls”

- Your comments should be limited to the **red-lines portions of the ballot only.**
- This ballot covers the API 520 TF action item 2015-12
- If you are voting negative, please indicate which of your comment or comments are the reason for your negative vote. API’s Balloting system will categorize all of your comments as Negative.

Thanks to John Burgess and his team for development on this ballot.

Phil Henry
TF520 Chairman

This document is not an API Standard; it is under consideration within an API technical committee but has not received all approvals required to become an API Standard. It shall not be reproduced or circulated or quoted, in whole or in part, outside of API committee activities except with the approval of the Chairman of the committee having jurisdiction and staff of the API Standards Dept. Copyright API. All rights reserved.

Sizing, Selection, and Installation of Pressure-relieving Devices

Part II—Installation

API STANDARD 520, PART II
SEVENTH EDITION, OCTOBER 2020



This document is not an API Standard; it is under consideration within an API technical committee but has not received all approvals required to become an API Standard. It shall not be reproduced or circulated or quoted, in whole or in part, outside of API committee activities except with the approval of the Chairman of the committee having jurisdiction and staff of the API Standards Dept. Copyright API. All rights reserved.

Contents

	Page
1 Scope	1
2 Normative References	1
3 Terms and Definitions	1
4 PRD Location	1
4.1 General	1
4.2 Proximity to Protected Equipment	1
4.3 Pressure Fluctuations	1
4.4 Vibration	3
4.5 Operating Environment	3
4.6 Free-draining	3
4.7 Maintainability	3
5 Inlet Piping Requirements	3
5.1 General	3
5.2 Inlet Piping Diameter Requirements	4
5.3 Layout	4
5.4 Isolation Valves in Inlet Piping	6
5.5 Process Laterals Connected to Inlet Piping of PRVs	7
5.6 PRV Inlet Line Length and Pressure Loss	7
5.7 Inlet Stresses that Originate from Static Loads in the Discharge Piping	8
5.8 Inlet Stresses that Originate from Discharge Reaction Forces	8
6 Discharge Piping	11
6.1 General	11
6.2 Safe Disposal of Relieving Fluids	12
6.3 Backpressure Limitations and Sizing of Pipe	12
6.4 Considerations for Pilot-Operated PRVs	12
6.5 Stresses in Discharge Piping During Release	13
6.6 Isolation Valves in the Discharge Piping	13
6.7 Rupture Disks Installed at the Outlet of a PRV	13
7 PRV Stability	13
7.1 General	13
7.2 Potential Causes of PRV Instability	14
7.3 PRV Inlet Pressure Drop Limitations	16
8 PRD Isolation (Stop) Valves	25
8.1 General	25
8.2 Application	25
8.3 Isolation Valve Requirements	25
8.4 Examples of Isolation Valve Installations	32
8.5 Administrative Controls Related to Isolation Valves	33
9 Rupture Disk Installations	35
9.1 Rupture Disk Devices in Combination with PRVs	35
9.2 Rupture Disks In Series	37
10 Bonnet or Pilot Vent Piping	37
10.1 General	37
10.2 Conventional Valves	37

Contents

	Page
10.3 Balanced Bellows Valves	37
10.4 Balanced Piston Valves.....	42
10.5 Pilot-Operated Valves	42
11 Drain Piping	43
11.1 Installation Conditions that Require Drain Piping	43
11.2 Safe Practice for Installation of Drain Piping.....	43
12 Pre-installation Handling and Inspection	43
12.1 General	43
12.2 Storage and Handling of PRDs	43
12.3 Inspection and Cleaning of Systems Before Installation	44
13 Pressure-relief Device Installation and Maintenance	44
13.1 Mounting Position	44
13.2 Care in Installation.....	44
13.3 PRVs	44
13.4 Rupture Disk Devices	44
13.5 Pin-actuated Devices	45
13.6 Proper Gasketing and Bolting for Service Requirements	45
13.7 Inspection and Maintenance	45
13.8 Test or Lifting Levers.....	45
13.9 Heat Tracing and Insulation	45
Annex A (informative) Rupture Disk Installation Guidelines	46
Annex B (informative) Installation and Maintenance of Pin-actuated Non-reclosing PRDs.....	52
Annex C (informative) PRV Acoustic Interaction.....	54
Bibliography	57
Figures	
1 Typical Installation Avoiding Unstable Flow Patterns at PRV Inlet.....	2
2 Typical Pressure-relief Valve Installation: Atmospheric (Open) Discharge	4
3 Typical Pressure-relief Valve Installation: Closed System Discharge	5
4a Typical Rupture Disk Device Installation: Atmospheric (Open) Discharge.....	6
4b Typical Rupture Disk Device Installation: Atmospheric (Open) Discharge.....	6
5 Avoiding Process Laterals Connected to Pressure-relief Valve Inlet Piping	7
6 Typical Pressure-relief Valve Installation with Vent Pipe	9
7 Typical Pressure-relief Valve Mounted on Process Line.	21
8 Typical Pressure-relief Valve Mounted on Long Inlet Pipe	22
9 Typical Pilot-Operated Pressure-relief Valve Installation	24
10 Typical PRD Installation with an Isolation Valve	28
11 Typical PRD Installation for 100 % Spare Relieving Capacity	29
12 Alternate PRD Installation for 100 % Spare Relieving Capacity.....	30
13 Three-Way Changeover Valve—Shuttle Type.....	31
14 Three-Way Changeover Valve—Rotor Type.....	31
15 Three-Way Changeover Valve—Ball Types.....	33
16 Typical Flare Header Block Valves	34
17 Typical Isolation Block Valves for Spare Compressor	35

This document is not an API Standard; it is under consideration within an API technical committee but has not received all approvals required to become an API Standard. It shall not be reproduced or circulated or quoted, in whole or in part, outside of API committee activities except with the approval of the Chairman of the committee having jurisdiction and staff of the API Standards Dept. Copyright API. All rights reserved.

18 Typical Rupture Disk Device in Combination With Relief Valve: Inlet Side Installation36

BALLOT DRAFT

This document is not an API Standard; it is under consideration within an API technical committee but has not received all approvals required to become an API Standard. It shall not be reproduced or circulated or quoted, in whole or in part, outside of API committee activities except with the approval of the Chairman of the committee having jurisdiction and staff of the API Standards Dept. Copyright API. All rights reserved.

Contents

	Page
19 Bonnet Vent for Bellows Valves with Vent Located at the PRV	39
20 Bonnet Vent for Bellows Valves Handling Vapor with Remote Vent Location	40
21 Bonnet Vent for Bellows Valves Handling Liquids Where a Leak Needs to Be Routed Away from the PRV	41
22 Bonnet Vent for Bellows Valves Handling Liquids or Flashing Liquid and Vapor with Remote Vent Location	42
A.1 Typical Configuration of Companion Flanges, Gaskets, and Rupture Disk Assembly	47
A.2 Proper Handling of a Rupture Disk	49
A.3 Improper Handling of a Rupture Disk	49
A.4 Proper Alignment of Rupture Disk Indicated by Tag Arrows	50

Sizing, Selection, and Installation of Pressure-relieving Devices

Part II—Installation

1 Scope

This standard covers methods of installation for pressure-relief devices (PRDs) for equipment that has a maximum allowable working pressure (MAWP) of 15 psig (1.03 barg or 103 kPAg) or greater. Pressure-relief valves (PRVs) or rupture disks (RDs) may be used independently or in combination with each other to provide the required protection against excessive pressure accumulation. As used in this standard, the term pressure-relief valve includes safety-relief valves used in either compressible or incompressible fluid service, and relief valves used in incompressible fluid service. This standard covers gas, vapor, steam, two-phase, and incompressible fluid service; it does not cover special applications that require unusual installation considerations.

2 Normative References

The following referenced documents are indispensable for the application of this document. For dated references, only the edition cited applies. For undated references, the latest edition of the referenced document (including any amendments) applies.

API Standard 520, *Sizing, Selection, and Installation of Pressure-relieving Devices, Part I—Sizing and Selection*

3 Terms and Definitions

The terminology for PRDs that is used in this standard is in general agreement with the definitions given in API 520, Part I.

4 PRD Location

4.1 General

~~There are a number of design factors to be considered when determining the location of the PRD. There are a number of design factors that should be considered when determining the location of the PRD.~~

4.2 Proximity to Protected Equipment

~~Where possible, the PRD should be connected directly to the protected equipment or system of equipment. If the PRD is placed remotely, the connecting system shall be designed so that the pressure in the protected equipment stays within code allowable limits and to avoid PRV instability. (see Section 7) If other factors permit, the PRD should normally be placed close to the protected equipment or system of equipment so that the pressure in the protected equipment stays within code allowable limits and to avoid PRV instability (see Section 7).~~

~~See 7.3.3 for establishing set pressures for PRDs remotely located from protected equipment. See 7.3.3 for guidance on establishing set pressure if PRD will be remote from the protected equipment.~~

4.3 Pressure Fluctuations

The PRD should not be located where there are pressure fluctuations large enough to result in relief valve simmering/activation or rupture disk fatigue. On installations that have pressure fluctuations that peak close to the set pressure of the PRV or burst pressure of a rupture disk, the PRD should be located farther from the source and in a more stable pressure region.

This document is not an API Standard; it is under consideration within an API technical committee but has not received all approvals required to become an API Standard. It shall not be reproduced or circulated or quoted, in whole or in part, outside of API committee activities except with the approval of the Chairman of the committee having jurisdiction and staff of the API Standards Dept. Copyright API. All rights reserved.

Examples of areas that may have pressure fluctuations include:

- locations close to control valves, other valves, and other appurtenances;
- locations close to orifice plates and flow nozzles;
- locations close to other fittings, such as short radius elbows;
- locations close to the discharge of positive displacement pumps or compressors.

The potential effect of pressure fluctuations on the relief device may be reduced by the following (see Figure 1):

- locating the PRD 10 or more pipe diameters from any areas as described above;
- providing a well-rounded, smooth branch connection where the relief device inlet piping joins the main piping run;
- providing a larger branch connection (relative to the size of the PRV inlet).

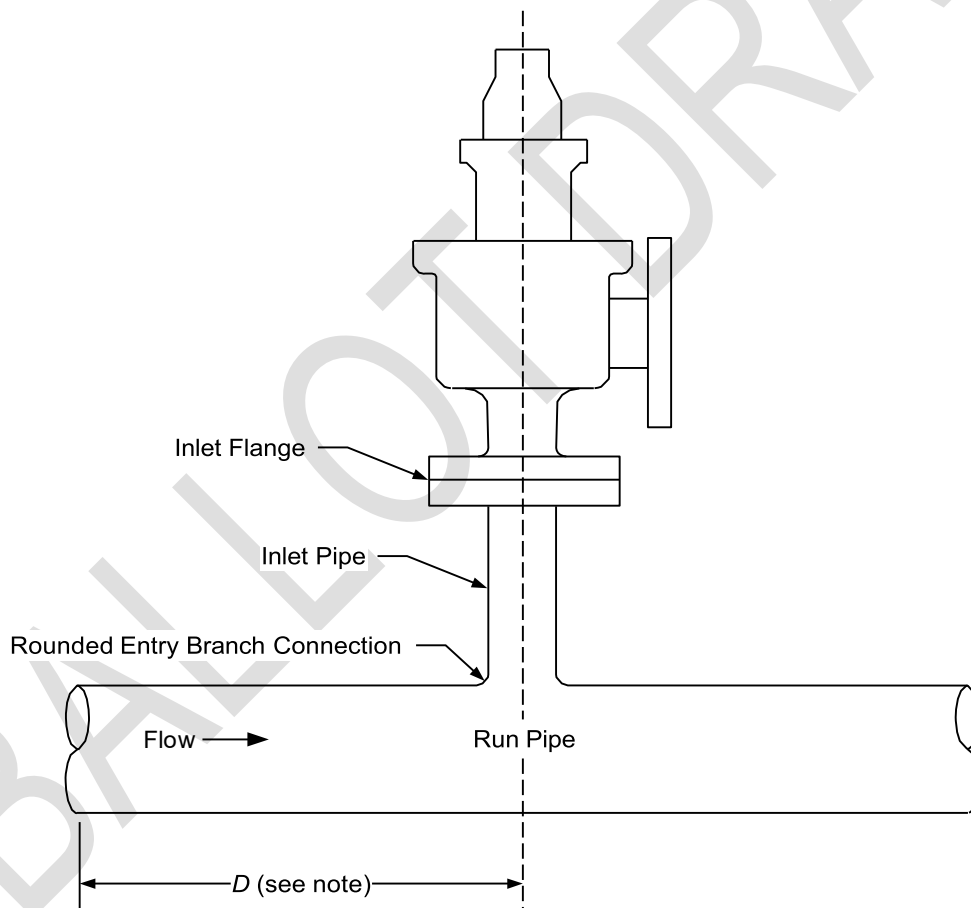

NOTE D is typically not less than 10 pipe diameters from any source that causes unstable flow.

Figure 1—Typical Installation Avoiding Unstable Flow Patterns at PRV Inlet

This document is not an API Standard; it is under consideration within an API technical committee but has not received all approvals required to become an API Standard. It shall not be reproduced or circulated or quoted, in whole or in part, outside of API committee activities except with the approval of the Chairman of the committee having jurisdiction and staff of the API Standards Dept. Copyright API. All rights reserved.

4.4 Vibration

Most vibrations that occur in piping systems are random and complex. These vibrations may cause leakage at the seat of a PRV, premature opening, or premature fatigue failure of certain valve parts or piping. Vibration in rupture disk piping may adversely affect the burst pressure and life of the rupture disk.

Detrimental effects of vibrations on the PRD can be reduced by addressing the cause of vibrations, by additional piping support, by use of either pilot-operated relief valves or soft-seated PRVs, or by providing greater PRD operating margins.

4.5 Operating Environment

~~PRDs should not be located where process conditions negatively impacts PRD reliability. When locating PRDs, consideration should be given to process conditions that could affect PRD reliability.~~ Locating a PRD in a cleaner or cooler portion of the process may be preferable.

4.6 Free-draining

The PRD inlet and outlet piping should be free-draining (no pockets) away from the PRD. See Section 11.

4.7 Maintainability

The PRD should be installed in a location that facilitates access and maintenance.

5 Inlet Piping Requirements

5.1 General

For general requirements for inlet piping, see Figure 2, Figure 3, Figure 4a, and Figure 4b.

This document is not an API Standard; it is under consideration within an API technical committee but has not received all approvals required to become an API Standard. It shall not be reproduced or circulated or quoted, in whole or in part, outside of API committee activities except with the approval of the Chairman of the committee having jurisdiction and staff of the API Standards Dept. Copyright API. All rights reserved.

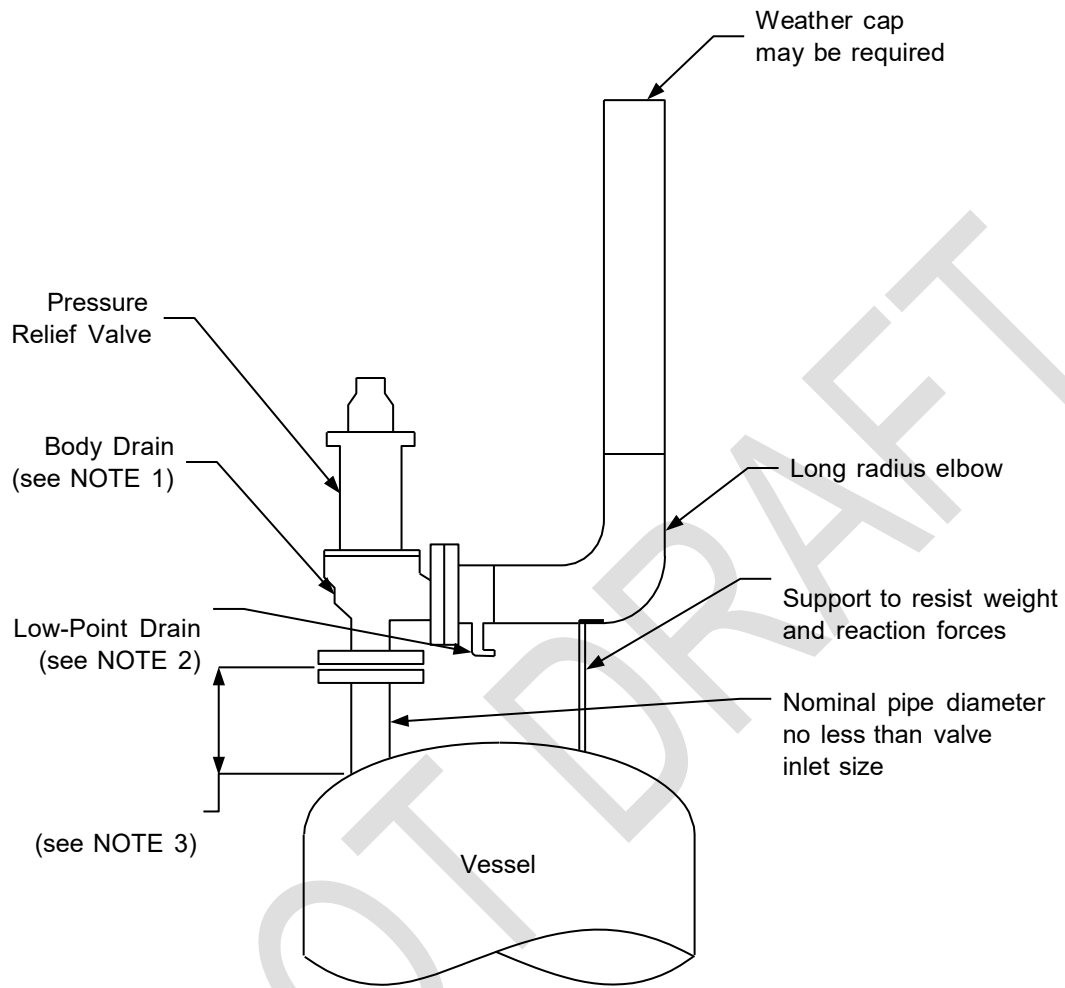

NOTE 1 See Section 11 for a discussion on the use of the valve body drain.

NOTE 2 Orient low point drain—or weep hole—away from relief valve, structural steel, and operating area.

NOTE 3 See 7.3 for PRV inlet pressure drop limitations.

Figure 2—Typical Pressure-relief Valve Installation: Atmospheric (Open) Discharge

5.2 Inlet Piping Diameter Requirements

The nominal size of the inlet piping and fittings shall be the same as or larger than the nominal size of the pressure-relief valve inlet connection as shown in Figure 2 and Figure 3.

When two or more active pressure-relief valves are placed on one connection, the inlet internal cross-sectional area of this connection shall be sized to avoid restricting flow to the pressure-relief devices or made at least equal to the combined inlet areas of the in-service pressure-relief devices connected to it. The flow characteristics of this upstream system shall be such that the pressure drop will not reduce the relieving capacity below that required, or adversely affect the proper operation, of the pressure-relief valve.

5.3 Layout

The inlet piping system to PRDs should be free-draining to prevent accumulation of liquid or foreign matter in

This document is not an API Standard; it is under consideration within an API technical committee but has not received all approvals required to become an API Standard. It shall not be reproduced or circulated or quoted, in whole or in part, outside of API committee activities except with the approval of the Chairman of the committee having jurisdiction and staff of the API Standards Dept. Copyright API. All rights reserved.

the piping.

BALLOT DRAFT

This document is not an API Standard; it is under consideration within an API technical committee but has not received all approvals required to become an API Standard. It shall not be reproduced or circulated or quoted, in whole or in part, outside of API committee activities except with the approval of the Chairman of the committee having jurisdiction and staff of the API Standards Dept. Copyright API. All rights reserved.

Horizontal lines are generally regarded as self-draining. However, avoid the installation of a PRV at the end of a long horizontal inlet pipe through which there is normally no flow. Solids, such as rust or scale, may accumulate, or liquid may be trapped, creating interference with the valve's operation or requiring more frequent valve maintenance.

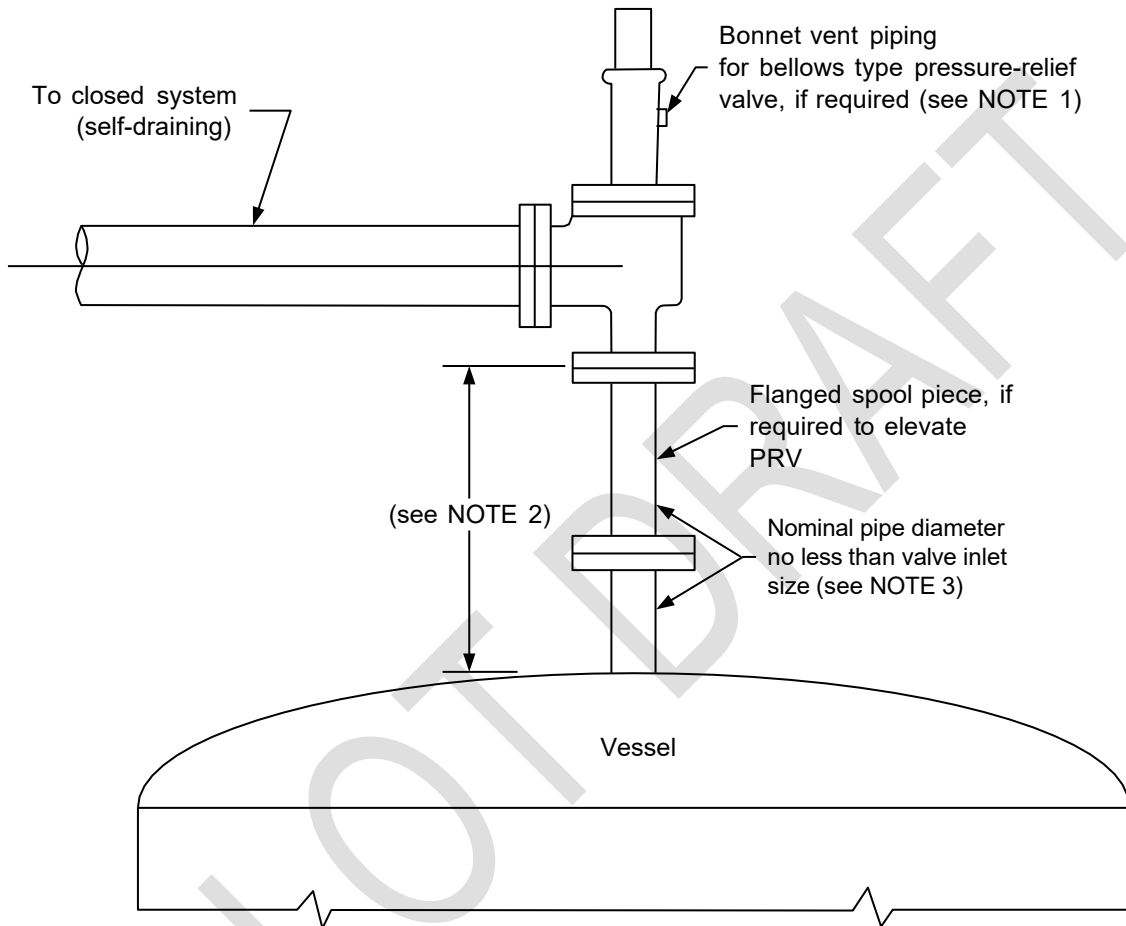

NOTE 1 See Section 10 for a discussion on bonnet venting.

NOTE 2 See 7.3 for PRV inlet pressure drop limitations.

NOTE 3 See 5.2 for inlet piping area requirements.

Figure 3—Typical Pressure-relief Valve Installation: Closed System Discharge

This document is not an API Standard; it is under consideration within an API technical committee but has not received all approvals required to become an API Standard. It shall not be reproduced or circulated or quoted, in whole or in part, outside of API committee activities except with the approval of the Chairman of the committee having jurisdiction and staff of the API Standards Dept. Copyright API. All rights reserved.

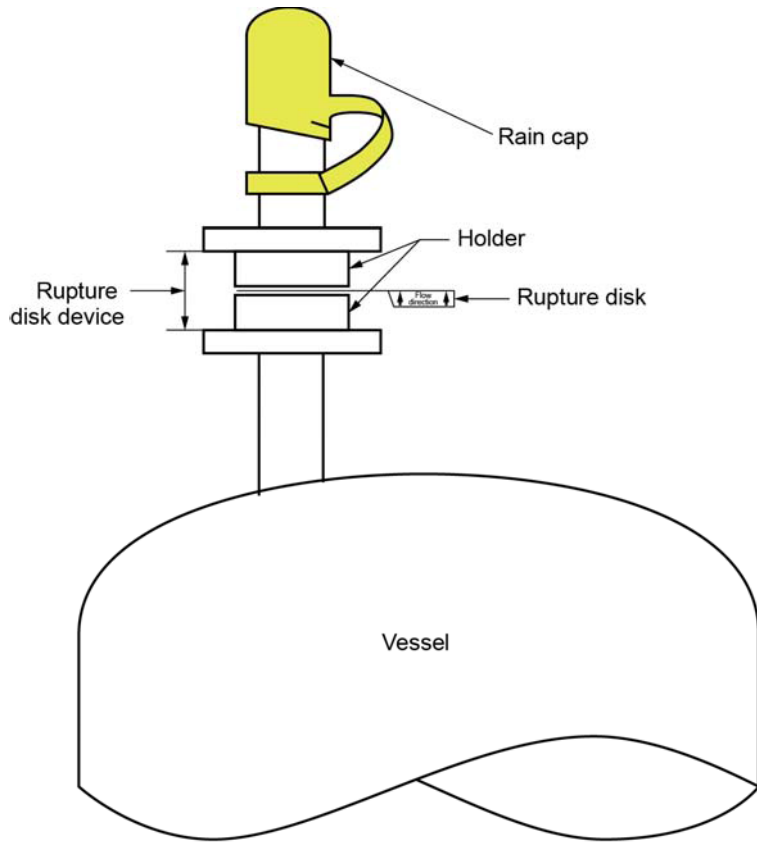

Figure 4a—Typical Rupture Disk Device Installation: Atmospheric (Open) Discharge

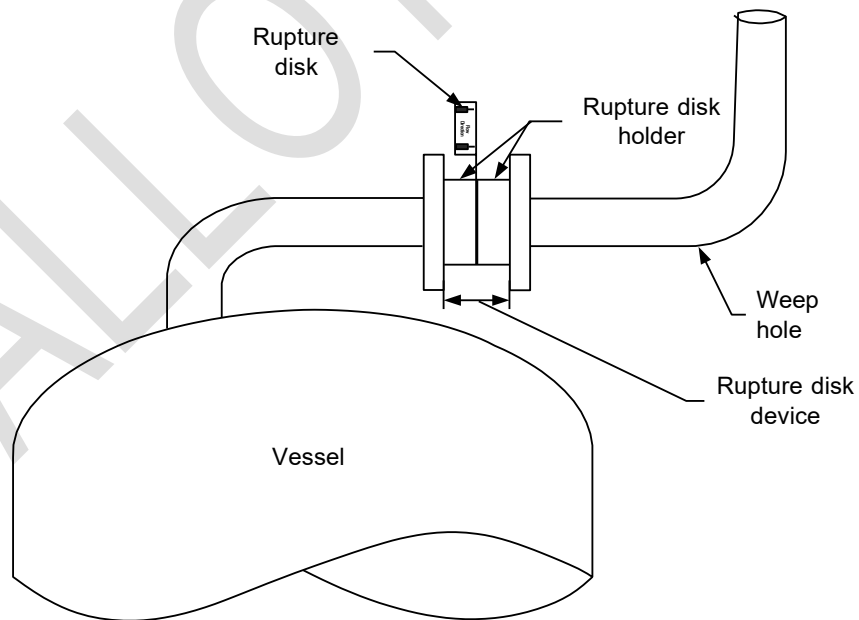

Figure 4b—Typical Rupture Disk Device Installation: Atmospheric (Open) Discharge

5.4 Isolation Valves in Inlet Piping

This document is not an API Standard; it is under consideration within an API technical committee but has not received all approvals required to become an API Standard. It shall not be reproduced or circulated or quoted, in whole or in part, outside of API committee activities except with the approval of the Chairman of the committee having jurisdiction and staff of the API Standards Dept. Copyright API. All rights reserved.

~~See Section 8 for guidelines for isolation valves in relief device piping. Isolation valves located in the inlet piping to PRDs shall be in accordance with the guidelines in Section 8.~~

BALLOT DRAFT

This document is not an API Standard; it is under consideration within an API technical committee but has not received all approvals required to become an API Standard. It shall not be reproduced or circulated or quoted, in whole or in part, outside of API committee activities except with the approval of the Chairman of the committee having jurisdiction and staff of the API Standards Dept. Copyright API. All rights reserved.

5.5 PRVs Connected to Process Piping~~Process Laterals Connected to Inlet Piping of PRVs~~

The pressure drop for PRVs installed on process piping should be analyzed to ensure that the allowable pressure drop at the inlet of the PRV is not exceeded with simultaneous flow through the PRV and flow through the process piping.~~Process laterals should generally not be connected to the inlet piping of PRVs (see Figure 5). Exceptions should be analyzed carefully to ensure that the allowable pressure drop at the inlet of the PRV is not exceeded with simultaneous flow through the PRV and flow through the process lateral.~~

5.6 PRV Inlet Line Length and Pressure Loss

The length of the PRV inlet line and its pressure drop can be factors in whether the PRV will cycle, chatter, or flutter. See 7.3 for guidance.

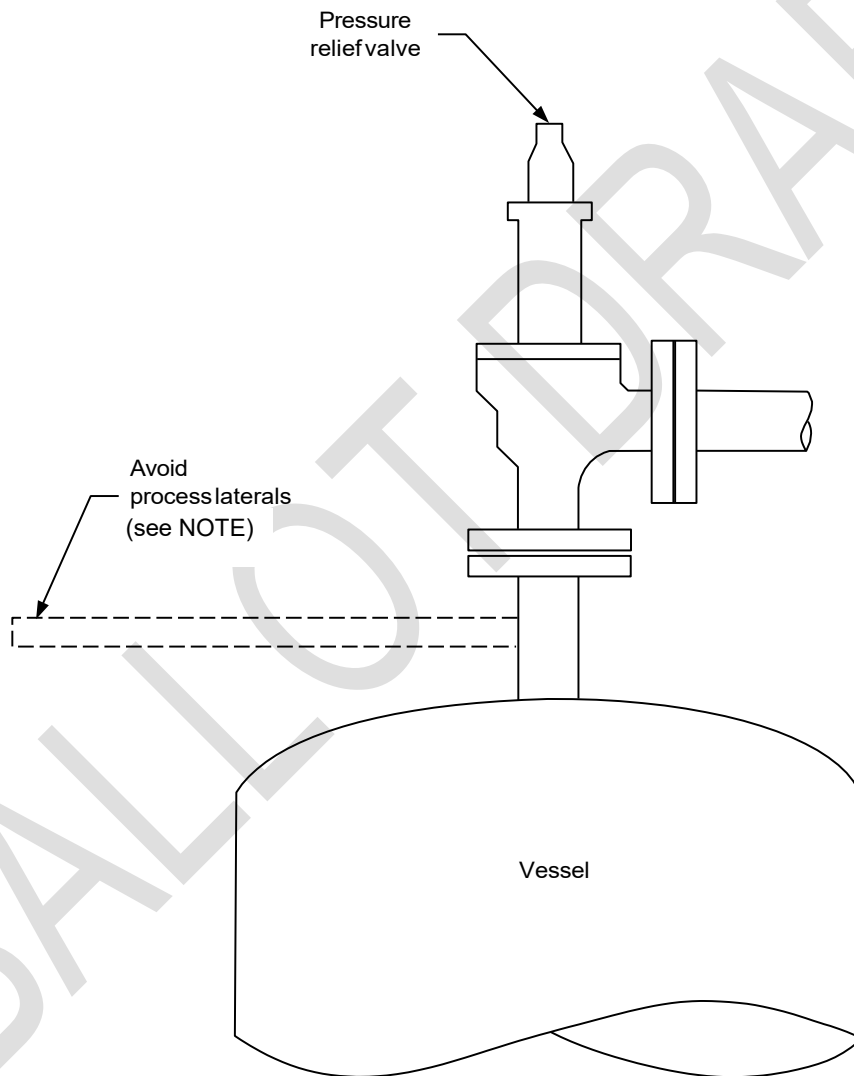

NOTE See 5.5 for cautions related to process laterals installed on pressure-relief inlet piping.

Figure 5—Avoiding Process Laterals Connected to Pressure-relief Valve Inlet Piping

This document is not an API Standard; it is under consideration within an API technical committee but has not received all approvals required to become an API Standard. It shall not be reproduced or circulated or quoted, in whole or in part, outside of API committee activities except with the approval of the Chairman of the committee having jurisdiction and staff of the API Standards Dept. Copyright API. All rights reserved.

5.7 Inlet Stresses that Originate from Static Loads in the Discharge Piping

5.7.1 General

Improper design or construction of the discharge piping from a PRD can set up stresses that will be transferred to the PRD and its inlet piping. Static loads are stresses that occur during normal operation while the relief device remains closed. These stresses may cause a PRV to leak or malfunction, may change the burst pressure of a rupture disk, or may cause connected equipment flanges to leak. Consult manufacturer's documentation for maximum allowable nozzle loads.~~The PRD manufacturer should be consulted about permissible loads.~~

5.7.2 Thermal Stresses

Fluid flowing from the discharge of a PRD may cause a change in the temperature of the discharge piping. A change in temperature may also be caused by prolonged exposure to the sun or to heat radiated from nearby equipment. Any change in the temperature of the discharge piping will cause a change in the length of the piping and may cause stresses that will be transmitted to the PRD and its inlet piping. PRD discharge nozzle loads should be less than the manufacturer's maximum allowable loads through proper supports, anchors, or flexibility of the discharge piping.~~The PRD should be isolated from piping stresses through proper support, anchoring, or flexibility of the discharge piping.~~

5.7.3 Mechanical Stresses

Discharge piping should be independently supported and aligned. Discharge piping that is supported by only the PRD will induce stresses in the PRD and the inlet piping. Forced alignment of the discharge piping will also induce such stresses.

5.8 Inlet Stresses that Originate from Discharge Reaction Forces

5.8.1 General

The discharge of a PRD will impose a reaction force (F) as a result of the flowing fluid (see Figure 6). This force will be transmitted into the PRD and into the mounting nozzle and adjacent supporting vessel shell unless designed otherwise. The precise magnitude of the loading and resulting stresses will depend on the reaction force and the configuration of the piping system. The user is cautioned that terminating the PRV discharge piping to any angle other than vertical with a perpendicular cut may increase the system stresses. The designer is responsible for analyzing the discharge system in compliance with the code of construction (e.g. ASME B31.3 ^[6]) to determine if the reaction forces and the associated bending moments will cause excessive stresses on any of the components in the system. A method for the design of piping systems to withstand reaction forces from PRDs is given in Appendix II of ASME B31.1 ^[5].

The magnitude of the reaction force will differ substantially depending on whether the installation is open or closed discharge. When an elbow is installed in the discharge system to direct the fluid up into a vent pipe, the location of the elbow and any supports is an important consideration in the analysis of the bending moments. The support should be located close to the centerline of the vertical vent pipe.

This document is not an API Standard; it is under consideration within an API technical committee but has not received all approvals required to become an API Standard. It shall not be reproduced or circulated or quoted, in whole or in part, outside of API committee activities except with the approval of the Chairman of the committee having jurisdiction and staff of the API Standards Dept. Copyright API. All rights reserved.

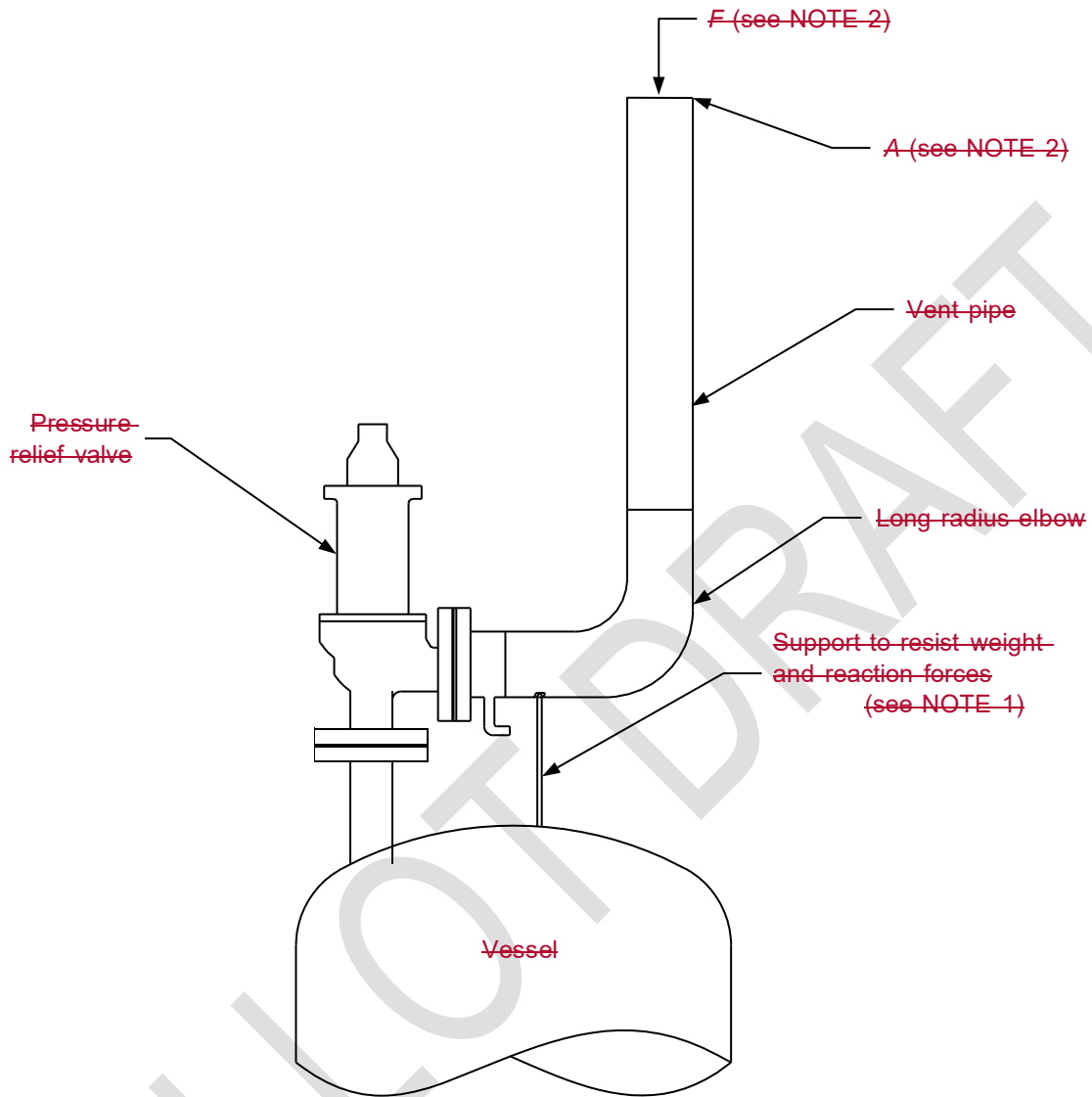

This document is not an API Standard; it is under consideration within an API technical committee but has not received all approvals required to become an API Standard. It shall not be reproduced or circulated or quoted, in whole or in part, outside of API committee activities except with the approval of the Chairman of the committee having jurisdiction and staff of the API Standards Dept. Copyright API. All rights reserved.

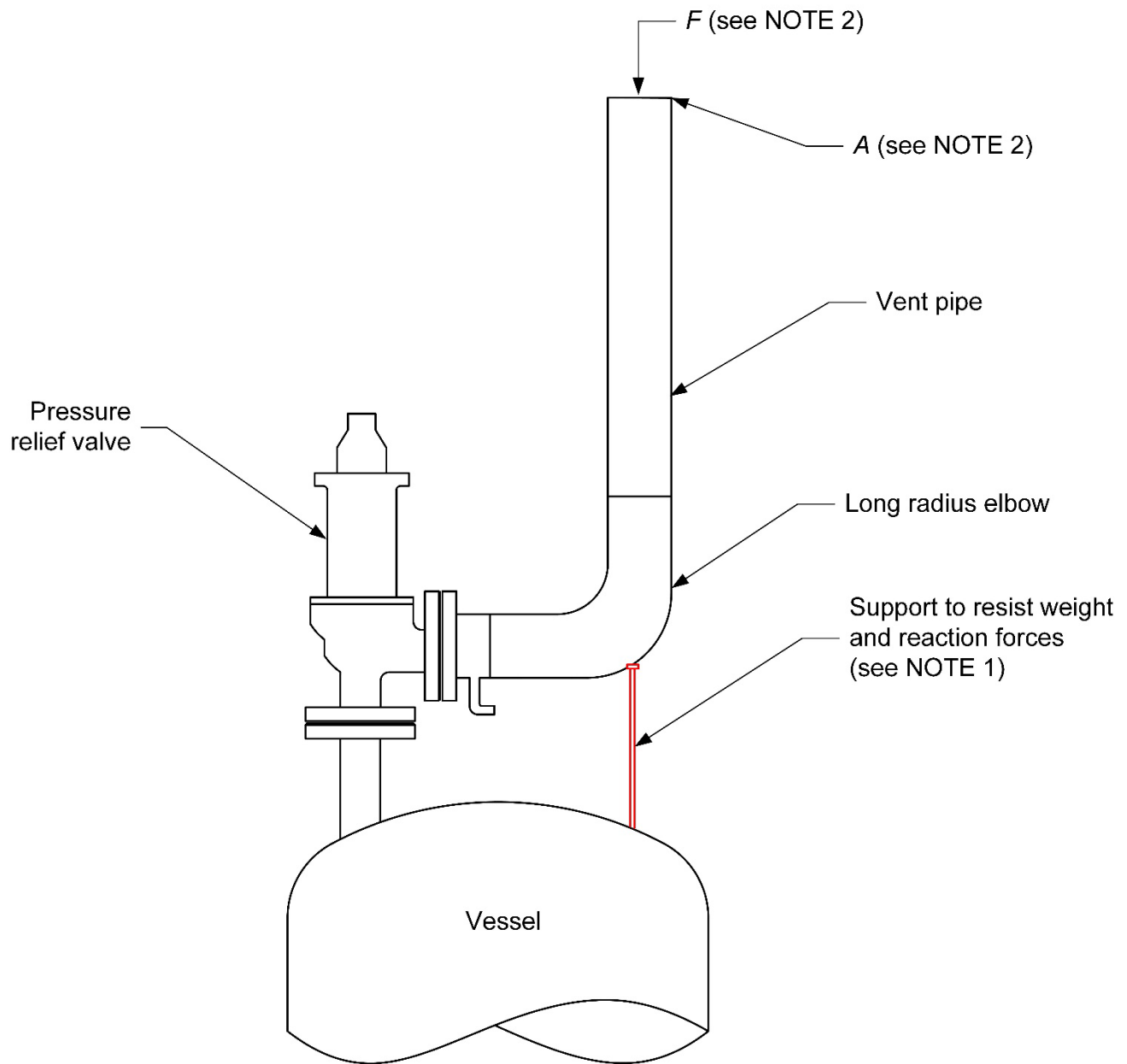

NOTE 1 The support should be located as close as possible to the centerline of the vertical vent pipe.

NOTE 2 F = reaction force; A = cross-sectional area.

Figure 6—Typical Pressure-relief Valve Installation with Vent Pipe

5.8.2 Determining Reaction Forces in an Open Discharge System

5.8.2.1 Vapor Discharge

The following formula is based on a condition of critical steady state flow of a compressible fluid that discharges to the atmosphere through an elbow and a vertical discharge pipe. The reaction force (F) includes the effects of both momentum and static pressure; thus, for any gas, vapor, or steam:

in USC units:

$$F = \frac{W}{366} \sqrt{\frac{kT}{(k+1)M}} + (AP) \quad (1)$$

in SI units:

$$F = 129W \sqrt{\frac{kT}{(k+1)M}} + \frac{(AP)}{1000}$$

where

F is the reaction force at the point of discharge to the atmosphere, in lbf [N];

W is the flow of any gas or vapor, in lb_m/hr [kg/s];

k is the ratio of specific heats (C_p/C_v) at the outlet conditions;

C_p is the specific heat at constant pressure;

C_v is the specific heat at constant volume;

T is the stagnation temperature at the pipe outlet, in °R [K]. Note that the stagnation temperature is often not available. If this is the case, a suitable approximation is the relieving temperature. ~~The user is cautioned that while this approximation is conservative for determination of reaction forces, the relieving temperature shall not be used for other discharge piping design aspects as this does not consider auto-refrigeration or Joule-Thompson cooling effects.~~

M is the molecular weight of the process fluid;

A is the area of the outlet at the point of discharge, in in.² [mm²];

P is the static pressure within the outlet pipe immediately before terminal expansion to atmosphere, in psig [kPa (gauge)].

5.8.2.2 Two-Phase Discharge

Although this paragraph provides a formula for the calculation of reaction forces for a two-phase release to atmosphere, the reader is cautioned to carefully consider the decision for atmospheric discharge. ~~Directing flammable or hazardous liquids to atmosphere should be avoided. Due consideration should be given to the potential for liquid portions of the release to cause a hazardous condition.~~ Consult API 521^[3] for additional guidance on atmospheric discharge.

The following formula can be used to determine the reaction force on inlet piping from an open discharge of

This document is not an API Standard; it is under consideration within an API technical committee but has not received all approvals required to become an API Standard. It shall not be reproduced or circulated or quoted, in whole or in part, outside of API committee activities except with the approval of the Chairman of the committee having jurisdiction and staff of the API Standards Dept. Copyright API. All rights reserved.

a two-phase fluid. The formula assumes that the two-phase mixture is in homogeneous flow condition (no-slip).

BALLOT DRAFT

This document is not an API Standard; it is under consideration within an API technical committee but has not received all approvals required to become an API Standard. It shall not be reproduced or circulated or quoted, in whole or in part, outside of API committee activities except with the approval of the Chairman of the committee having jurisdiction and staff of the API Standards Dept. Copyright API. All rights reserved.

in USC units:

$$F = \frac{W^2}{2.898 \times 10^6 A} \left[\frac{x}{\rho_g} + \frac{(1-x)}{\rho_l} \right] + AP \quad (2)$$

in SI units:

$$F = \frac{1 \times 10^6 \times W^2}{A} \left[\frac{x}{\rho_g} + \frac{(1-x)}{\rho_l} \right] + \frac{AP}{100}$$

where

- F is the reaction force at the point of discharge to the atmosphere, in lbf [N];
- W is the flow rate, in lb_m/hr [kg/s];
- x is the weight fraction vapor at exit conditions;
- ρ_g is the vapor density at exit conditions, in lb_m/ft³ [kg/m³];
- ρ_l is the liquid density at exit conditions, in lb_m/ft³ [kg/m³];
- A is the area of the outlet at the point of discharge, in in.² [mm²];
- P is the static pressure within the outlet pipe immediately before terminal expansion to atmosphere, in psig [kPa (gauge)].

An example showing the reaction force calculation can be found in CCPS.^[35]

5.8.3 Determining Reaction Forces in a Closed Discharge System

PRDs that relieve under steady state flow conditions into a closed system usually do not transfer large forces and bending moments to the inlet system because changes in pressure and velocity within the closed system components are small.

Only at points of sudden expansion in the discharge piping will there be any significant inlet piping reaction forces to be calculated. Closed discharge systems, however, do not lend themselves to simplified analytical techniques. A complex time history analysis of the piping system may be required to obtain the reaction forces and associated moments that are transferred to the inlet piping system.

6 Discharge Piping

6.1 General

For general requirements for discharge piping, see Figure 2, Figure 3, Figure 6, and Figure 10.

The discharge piping installation shall provide for proper PRD performance and adequate drainage. Free-draining systems are preferred; when free-draining is not possible see Section 11. (~~free—draining systems are preferred; see Section 11~~). ~~Consideration should be given to the type of discharge system used, the backpressure on the PRD, and the set pressure relationship of the PRDs in the system.~~

All aspects of the discharge piping, including material selection, shall be designed for the expected discharge piping temperature. The fluid temperature can be used as a conservative estimate of the piping temperature

This document is not an API Standard; it is under consideration within an API technical committee but has not received all approvals required to become an API Standard. It shall not be reproduced or circulated or quoted, in whole or in part, outside of API committee activities except with the approval of the Chairman of the committee having jurisdiction and staff of the API Standards Dept. Copyright API. All rights reserved.

Auto-refrigeration during discharge can cool the outlet of the PRD and the discharge piping to the point that brittle fracture can occur. ~~Piping design, including material selection, shall consider the expected discharge temperature.~~

6.2 Safe Disposal of Relieving Fluids

For a comprehensive source of information about the safe disposal of various relieving fluids, see API 521^[3].

6.3 Backpressure Limitations and Sizing of Pipe

6.3.1 General

~~The discharge piping design shall ensure the superimposed and built-up backpressure do not adversely affect the operating characteristics of the PRDs. When discharge piping is designed, consideration should be given to the combined effect of superimposed and built-up backpressure on the operating characteristics of the PRDs. The discharge piping system should be designed so that the backpressure does not exceed an acceptable value for any PRD in the system.~~ See API 520, Part I for limitations on backpressure.

The rated capacity corrected for the actual overpressure of a conventional spring-loaded, balanced spring-loaded, or pop-action pilot-operated PRV should typically be used to size the atmospheric vent piping or the discharge line from the PRV to the relief header. Note that the rated capacity corrected for the actual overpressure can vary depending on the overpressure scenario. Common relief header piping in closed discharge systems can be sized using the protected system's required relieving capacity (see API 521).

For a modulating pilot-operated PRV, the discharge piping can be sized using the required relieving capacity of the system that the valve is protecting.

Whenever the atmospheric vent, discharge piping, or common relief header piping is sized using the system's required relieving capacity instead of the rated capacity of the valve corrected for the actual overpressure, the backpressure should be re-checked whenever changes are made to the process that affect the required relieving capacity of the system the valve is protecting.

For pressure drop calculations, when discharging incompressible or subsonic compressible flow to either a closed reservoir or the atmosphere, the static pressure within the exit of the pipe is numerically equal to the reservoir or atmospheric pressure, respectively. When discharging sonic compressible flow, the pressure within the exit of the pipe is the calculated choking pressure.^[8] Additional information on sizing of discharge piping systems for vapor or gas service is covered in API 521^[3].

6.3.2 Thermal Relief Valves

The discharge piping from thermal relief valves designed solely to protect against liquid hydraulic expansion due to ambient heating (including solar radiation) typically does not need to be sized to meet the built-up backpressure limits provided in API 520, Part I and as discussed in 6.3.1. The reason for this is that the capacity of these PRVs is typically larger by an order of magnitude (>10 times) than the required relief rate and the flow in the discharge line never reaches a steady state flow at the capacity. See 7.3.8 for additional discussion and cautions with thermal relief valves.

Examples where outlet pressure drop calculations for thermal expansion generated by ambient heating would be considered applicable are for a long pipeline or large liquid-filled vessel, where the required flow rate due to thermal expansion approaches the rated capacity of the valve corrected for the actual overpressure. The user is cautioned that for liquids (e.g. refrigerated liquids, LPG, or LNG) where blocking in with ambient heating may lead to vaporization and possible overpressure (not thermal relief), required relief rates may be large enough to warrant outlet pressure drop calculations.

Discharge piping for thermal relief valves in applications where pressure inside the protected equipment can be generated by process heat ~~should~~ shall be sized to meet the built-up backpressure limits provided in API 520, Part I. See 7.3.8 for inlet loss criteria for thermal relief valves.

This document is not an API Standard; it is under consideration within an API technical committee but has not received all approvals required to become an API Standard. It shall not be reproduced or circulated or quoted, in whole or in part, outside of API committee activities except with the approval of the Chairman of the committee having jurisdiction and staff of the API Standards Dept. Copyright API. All rights reserved.

6.4 Considerations for Pilot-Operated PRVs

Superimposed backpressure that exceeds the inlet pressure of a pilot-operated PRV can cause the main valve to open, allowing reverse flow through the main valve. For example, backflow can occur if several

BALLOT DRAFT

This document is not an API Standard; it is under consideration within an API technical committee but has not received all approvals required to become an API Standard. It shall not be reproduced or circulated or quoted, in whole or in part, outside of API committee activities except with the approval of the Chairman of the committee having jurisdiction and staff of the API Standards Dept. Copyright API. All rights reserved.

PRVs have their outlets manifolded into a common discharge header, and one or more of these valves is discharging while another is connected to a system with a lower inlet pressure. A backflow preventor should be specified that would prevent such backflow.

6.5 Stresses in Discharge Piping During Release

The reaction forces and stresses that originate in the downstream piping as a result of the release of a PRD are typically not significant once flow is established and has reached steady state conditions, due to small changes in pressure and velocity within the closed system components. However, large forces may result if there are sudden pipe expansions within the system or as a result of unsteady flow conditions during the initial activation of the relief device. Additionally, large reaction forces can be created at elbows as a result of two-phase fluid flow in the slug flow regime. The mechanical installation design shall include mechanical loads from the initial flow from a rupture disk (both steady state and transient loads). ~~Mechanical loads from the initial flow from a rupture disk (both steady state and transient loads) shall be included in the mechanical installation design.~~^[9]

The design of flare header piping in closed discharge systems ~~should~~ shall be in accordance with an applicable design code such as ASME B31.3^[6] or other applicable piping design code. The design of flare header piping is not amenable to simplified analytical techniques; consequently, assistance by individuals knowledgeable in pipe stress analysis is recommended. A complex dynamic analysis of the system may be required. API 521^[3] gives additional guidance on the design of flare header piping.

6.6 Isolation Valves in the Discharge Piping

See Section 8 for guidelines for isolation valves in relief device piping. ~~Isolation valves located in the discharge piping system shall be in accordance with the guidelines provided in Section 8.~~

6.7 Rupture Disks Installed at the Outlet of a PRV

A rupture disk device may be installed on the outlet of a PRV to protect the valve from downstream fluids. Selection of the relief valve and the installation of the system shall address the potential accumulation of pressure between the relief valve and the rupture disk. ~~Consideration shall be given to the PRV design so that it will open at its proper pressure setting regardless of any backpressure that may accumulate between the valve and rupture disk.~~ The pressure drop due to the rupture disk in the discharge piping shall be included in the hydraulic calculations. ~~The pressure drop due to the rupture disk in the discharge piping should be included in the hydraulic calculations.~~ See ASME BPCV XIII Part 8.3UG-127 of the ASME Boiler and Pressure Vessel Code, Section VIII [7] for other requirements and considerations.

7 PRV Stability

7.1 General

The flow rate through a PRV can readily change with changes in inlet and/or outlet pressures. The flow through PRVs is rarely steady state since the pressure at the PRV inlet is often dynamic throughout the duration of the overpressure scenario. A PRV may experience three types of dynamic responses to variable flow conditions: cycling, flutter, and chatter.

7.1.1 PRV Cycling

Cycling is the relatively low-frequency (e.g. a few cycles per second to a few seconds per cycle) opening and closing of a relief valve. This most often occurs when the relief requirement is small when compared to the capacity of the valve. In this case, when the PRV opens, the valve may flow more than what the system can provide, causing the pressure to drop to the PRV's reseating pressure. Once the PRV is closed, the system pressure rebuilds to the PRV set pressure and the cycle repeats. Cycling frequency is a function of the upstream system's ability to keep the valve open and is much lower than the natural frequency of the valve. In general, cycling does not cause detrimental valve damage. However, the valve's ability to reseat tightly

This document is not an API Standard; it is under consideration within an API technical committee but has not received all approvals required to become an API Standard. It shall not be reproduced or circulated or quoted, in whole or in part, outside of API committee activities except with the approval of the Chairman of the committee having jurisdiction and staff of the API Standards Dept. Copyright API. All rights reserved.

may be affected and it may cause some wear over time.

When capacity variations are frequently encountered in normal operation, one alternative is the use of multiple, smaller PRVs with staggered settings. With this arrangement, the PRV with the lowest setting will be capable of handling minor upsets, and additional PRVs will open as the capacity requirement increases.

BALLOT DRAFT

This document is not an API Standard; it is under consideration within an API technical committee but has not received all approvals required to become an API Standard. It shall not be reproduced or circulated or quoted, in whole or in part, outside of API committee activities except with the approval of the Chairman of the committee having jurisdiction and staff of the API Standards Dept. Copyright API. All rights reserved.

Refer to API 520, Part I, to determine set pressure of the PRVs based on maximum allowable pressure accumulation for multiple valve installations.

An alternative to the use of multiple PRVs with staggered settings is the use of a modulating pilot-operated relief valve.

7.1.2 PRV Flutter

Flutter is where the PRV is open, but the dynamics of the system cause abnormal, rapid reciprocating motion of the moveable parts of the PRV. During fluttering, the disk does not contact the seat but reciprocates near the natural frequency of the valve. Flutter may lead to rapid wear of any movable member that is in contact with a stationary member of the PRV and has a higher probability of causing the PRV to become stuck in a full or partially open position. Flutter can also lead to a reduction in capacity. Spring/mass systems that are used in spring-loaded PRVs create a higher potential for flutter than pilot-operated PRVs.

7.1.3 PRV Chatter

Chattering is where the PRV opens and closes at a very high frequency (on the order of the natural frequency of the valve's spring/mass system). Spring-loaded PRVs are spring/mass devices and consequently are susceptible to dynamic interaction with the system. The primary concern is loss of containment (loosening of flange bolts or failure of piping components due to fatigue) caused by pressure pulsation or impact loading from rapid hammering of the valve disk onto the valve seat. Chattering may lead to significantly reduced PRV flow capacity. As a secondary effect, the chattering can cause valve seat damage and mechanical failure of valve internals (galling and bellows failure). Spring-loaded PRVs and pop-action pilot valves can experience chatter (modulating pilot-operated or remote sensing pop-action pilot PRVs are less likely to chatter).

The damaging forces on piping associated with fluid pressure and velocity changes associated with chatter are much more severe in liquid service as compared to vapor service due to the higher densities associated with liquids. This is supported by analysis that shows that the pressure change as a result of fluid acceleration is typically small in inlet piping applications in vapor service^[18]. This is also supported by operating experience^[21], which shows that loss-of-containment incidents due to chatter are primarily in liquid service.

7.2 Potential Causes of PRV Instability

7.2.1 General

Research and experience show that PRV instability is complex and cannot be attributed to just one issue. Below is a list of potential operating/design issues that can contribute to PRV instability. There may be other phenomena that can lead to valve instability. Additionally, the user is cautioned that interactions among these phenomena and other factors may affect valve stability.

7.2.2 Excessive PRV Inlet Pressure Loss

A PRV will start to open at its set pressure, but under flowing conditions, the pressure acting on the valve disk will be reduced by an amount equal to the pressure drop through the inlet piping and fittings. If this pressure drop is sufficiently large, the valve inlet pressure may fall below reseating pressure, causing it to close, only to reopen immediately since the static pressure will be above the set pressure. Research and testing^{[14] [18] [29]} indicate that the instability associated with excessive inlet losses relative to the blowdown may lead to cycling, flutter, or chatter.

See 7.3 for guidance on limiting PRV inlet pressure drop.

This document is not an API Standard; it is under consideration within an API technical committee but has not received all approvals required to become an API Standard. It shall not be reproduced or circulated or quoted, in whole or in part, outside of API committee activities except with the approval of the Chairman of the committee having jurisdiction and staff of the API Standards Dept. Copyright API. All rights reserved.

7.2.3 Excessive Built-up Backpressure

Built-up backpressure resulting from discharge flow through the outlet system of a conventional PRV results in a force on the valve disc that tends to return it to the closed position. If this returning force is sufficiently large, it may cause the valve to close completely, only to reopen immediately when the discharge flow has stopped and built-up backpressure has dissipated. Instability results from the rapid repetition of this cycle.

To prevent instability from this mechanism, historical design practices for conventional PRV discharge systems have been to limit the built-up backpressure to the valve's allowable overpressure. Allowable valve overpressures are described in API 520, Part I. Where built-up backpressure exceeds these criteria, decreasing the flow resistance of the discharge system or using a balanced PRV, restricted lift PRV, or pilot-operated PRV are alternatives.

Several of the larger API 526 valves have multiple orifice sizes for the same inlet and outlet flange sizes. Using the rated capacity for the largest orifice size for a specific discharge flange size (e.g. 4P6, 6R8, etc.) can result in an excessive built-up backpressure for conventional valves even with a very short discharge line. In some cases, increasing the discharge line diameter to reduce the flow resistance will not reduce the built-up backpressure to acceptable levels due to choked flow in the expansion fitting ^{[11] [13] [15] [34]}. As mentioned above, a balanced PRV, restricted lift PRV, or pilot-operated PRV should be considered in such cases.

7.2.4 Acoustic Interaction

PRV instability due to acoustic interaction is complex and is an area of active research. A simple acoustic interaction model for a direct spring-loaded PRV is described below.

When the PRV opens rapidly, the pressure just upstream of the valve disc drops and a rarefaction pressure wave travels upstream at the speed of sound in the fluid. The pressure reduction at the PRV inlet will tend to return the valve disc to its closed position. When the pressure reduction wave reaches a large reservoir (a hydraulic boundary), a pressure wave reflection occurs. If the pressure wave returns quickly, then the PRV will stay open and is expected to flow in a stable manner or may flutter. ~~If the pressure wave returns quickly, the PRV will stay open and should flow in a stable manner or may flutter.~~ If, on the other hand, the PRV closes before the pressure wave returns, the PRV may cycle or chatter. The acoustic pressure waves are recoverable, so the PRV inlet pressure would rapidly build back up and the process would repeat. This phenomenon may contribute to instability in all fluid regimes; however, the effects of acoustic interaction are more pronounced with liquid reliefs as described in 7.1.3 ^{[19] [24] [25]}. See Annex C.

There is a separate acoustic phenomenon that may lead to PRV chatter in which the PRV inlet pipe acoustic quarter wave couples with the PRV disk motion. This is supported by recent test data and one-dimensional fluid dynamics modeling for gases and liquids ^{[14] [15] [20] [30] [33]}. PRV chatter is most severe where the PRV natural frequency matches or approaches the inlet piping acoustic quarter wave frequency.

7.2.5 Retrograde Condensation

Retrograde condensation can occur if the pressure of a supercritical process is dropped and the process conditions change from supercritical to two-phase (e.g. CO₂). The shift from supercritical to two-phase can result in a volumetric contraction and pressure reduction. When the PRV inlet pressure reaches set pressure, the PRV will rapidly open, which will result in a pressure reduction at the PRV inlet. If the process is supercritical and the reduced pressure causes retrograde condensation that results in significant amounts of liquid, the volumetric contraction and accompanying pressure reduction could cause the PRV to close. The pressure increase upon PRV closure causes a return to supercritical conditions (i.e. the condensed liquid returns to a supercritical fluid), which then causes the cycle to repeat. The effect can be PRV chatter. This can be avoided by process design (increasing operating pressures so that retrograde condensation occurs downstream of the PRV instead of in the PRV inlet) or possibly by using a remote sensing pilot-operated PRV ^[23].

This document is not an API Standard; it is under consideration within an API technical committee but has not received all approvals required to become an API Standard. It shall not be reproduced or circulated or quoted, in whole or in part, outside of API committee activities except with the approval of the Chairman of the committee having jurisdiction and staff of the API Standards Dept. Copyright API. All rights reserved.

7.2.6 Improper Valve Selection

Vapor certified PRVs are significantly more likely to chatter when relieving liquid than liquid certified PRVs. This is because liquid trim valves are designed to operate in a stable manner in liquid service. The user should review the applicable relief scenarios and select a PRV design that reduces the potential for this cause of chatter. ~~The user should understand the various relief scenarios and select a PRV design that reduces the potential for this cause of chatter.~~ See API 520, Part I, 4.2.1.4 for discussion.

7.2.7 Oversized PRVs

Oversized PRVs may lead to cycling (see 7.1.1). Oversizing of pressure-relief devices is frequently unavoidable. This is because the sizing case for a given relief device is often significantly larger than other relief cases. This is partly due to the conservative assumptions used in determining relief loads. For example, credit is not allowed for control system response that would reduce the relief load.

7.3 PRV Inlet Pressure Drop Limitations

7.3.1 General

The objectives for the evaluation of the changes in pressure en route to the PRV inlet are the following Evaluation of the pressure drop on the PRV inlet shall include the following:

- Confirm the inlet pressure losses do not ~~significantly affect~~ reduce the available ~~the~~ capacity of the PRV below that which is required (see 7.3.2).
- Confirm the PRV is set to open at or below the maximum allowable working pressure for all equipment being protected, except where permissible by applicable codes.
- Limit the pressure to the maximum allowable accumulation for all equipment being protected (see 7.3.3).
- Provide reasonable assurance that the inlet pressure losses are unlikely to result in destructive instability of the PRV (see 7.3.5).

7.3.2 PRV Capacity

The PRV sizing equations presented in API 520, Part I are based on nozzle flow equations that use the stagnation pressure at the inlet to the nozzle as a fundamental input variable. Any nonrecoverable pressure losses that occur from the protected equipment to the inlet flange of the PRV reduce the stagnation pressure at the inlet nozzle. This reduction in pressure directly reduces the capacity of the PRV. In typical installations where the 3 % criterion as detailed in 7.3.5 is satisfied, the magnitude of the nonrecoverable pressure losses is not expected to be significant and the effects of those pressure losses are typically neglected when determining the valve capacity. If the inlet loss exceeds 3 %, the capacity reduction due to the inlet losses cannot be neglected (see API 520, Part I, 5.4.1.1).

7.3.3 Adjustments to Set Pressures Based on Upstream System

The set pressure of a PRV is typically based on the MAWP or design pressure of the protected equipment, although other limiting pressures may become the basis for selecting the set pressure. The set pressure shall be adjusted so that the opening pressure does not exceed the maximum allowable per code and the maximum allowable accumulation is not exceeded while relieving. This adjustment includes the pressure drop between protected equipment and the PRV. Example installations where this can be a concern include the following. ~~The set pressure of a PRV is typically based on the MAWP or design pressure of the protected equipment, although other limiting pressures may become the basis for selecting the set pressure. The changes in the pressure between the protected equipment and the PRV should be evaluated to ensure that the opening pressure does not exceed the maximum allowed per code and to ensure that the maximum allowable accumulated pressure is not exceeded while relieving. Example installations where this can be a concern~~

This document is not an API Standard; it is under consideration within an API technical committee but has not received all approvals required to become an API Standard. It shall not be reproduced or circulated or quoted, in whole or in part, outside of API committee activities except with the approval of the Chairman of the committee having jurisdiction and staff of the API Standards Dept. Copyright API. All rights reserved.

~~include the following.~~

a) **Static liquid head between the protected equipment and the relief valve:** For liquid-filled systems, the liquid static head is taken into account by adjusting the set pressure of the PRV up or down by the equivalent static liquid head.

b) **Interconnected process equipment protected by a common PRV (such as a tower system or reactor train):** The set pressure of the common PRV ~~may need to shall~~ be adjusted downward ~~based on if~~ the pressure profile at the time of the upset ~~to ensure that the valve opens before pressure at any protected equipment in the system exceeds that results in either:~~

- ~~1. exceeding the MAWP prior to opening, except where permissible by code, or~~
- ~~2. exceeding the maximum allowable accumulation of any of the protected equipment during the relief event.~~

~~allowed by the design code. Further, any change in the pressure profile after the valve opens needs to be evaluated to ensure that the maximum allowable accumulated pressure is not exceeded on any of the protected equipment. See API 521, Annex B^[3] for an example.~~

~~e) **PRV located on process piping away from the protected equipment:** An example is where a PRV is located on a tower's overhead piping. The set pressure of the PRV may need to be adjusted downward based on the pressure profile at the time of the upset to ensure that the valve opens before pressure at any protected equipment in the system exceeds that allowed by the design code. Further, any change in the pressure profile after the valve opens needs to be evaluated to ensure that the maximum allowable accumulated pressure is not exceeded in any of the protected equipment. See API 521, Annex B^[3] for an example.~~

When the PRV set pressure is based on a pressure profile as discussed in 7.3.3 b) ~~and 7.3.3 c)~~, during low-throughput operation, the pressure at the PRV may increase, resulting in a smaller PRV operating margin and potential for nuisance PRV activation. Thus, the potential for turndown operation should be **considered evaluated** in the design of such installations.

7.3.4 PRV Inlet Pressure Loss Criteria

The total nonrecoverable pressure loss between the protected equipment and the pressure-relief valve should not exceed 3 % of the PRV set pressure, except as noted below:

- thermal relief valves (see 7.3.8);
- remotely sensed pilot-operated relief valves (see 7.3.9);
- an engineering analysis is performed for the specific installation (see 7.3.6).

Note that keeping the pressure loss below 3 % becomes progressively more difficult at low pressures and/or as the orifice size of a PRV increases. In certain applications, it is difficult to meet the 3 % criterion for the largest API 526^[2] orifice size for a given inlet flange diameter (e.g. 2J3, 4P6, 6R8, etc.). There are some non-API 526 valves that also exhibit this behavior.

7.3.5 Background on PRV Inlet Pressure Loss Criteria

Over the years, PRV inlet pressure loss criteria have evolved. The concept of limiting PRV inlet losses was first discussed in an API-sponsored report published by the University of Michigan^[27]. In 1963, API 520, Part II adopted an inlet pressure loss limit of 3 % of the PRV set pressure for installations having a less-than-full-bore inlet stop valve. In 1988, the 3 % inlet pressure loss criterion was extended to all PRVs, and in 1994, it was revised again, allowing inlet pressure losses greater than 3 % with an engineering analysis. For decades, many user companies have accepted PRV inlet losses up to 5 % when determining whether modifications to existing installations were warranted.

This document is not an API Standard; it is under consideration within an API technical committee but has not received all approvals required to become an API Standard. It shall not be reproduced or circulated or quoted, in whole or in part, outside of API committee activities except with the approval of the Chairman of the committee having jurisdiction and staff of the API Standards Dept. Copyright API. All rights reserved.

Limiting the inlet pressure drop to a specific value may not be sufficient to guarantee PRV stability. Recent research and experience indicate that PRV instability is complex and cannot be attributed to just pressure loss in the PRV inlet piping. Limited testing has shown that, in many cases, PRVs did not chatter when inlet losses exceeded 3 % of set pressure, while in some tests, PRVs chattered when inlet pressure losses were less than 3 %. Industry experience has shown PRV failures due to chatter are rare. Many existing PRVs in vapor service with inlet losses greater than 3 % of set pressure have not resulted in loss of containment while performing their function^[21]. Inlet pressure loss criteria alone are not sufficient to predict PRV stability. There are additional factors that also need to be considered, as shown in literature^{[15][20][29][30]}. Consequently, due to the complex nature of PRV instability behavior, further research is needed before changes to the inlet loss criteria in 7.3.4 can be justified.

7.3.6 Engineering Analysis

Experience has shown that many PRV installations with calculated inlet pressure drop greater than 3 % of set pressure have not resulted in failures due to relieving events. Because the relationship between inlet pressure loss and PRV chatter is not definitively understood, detailed requirements for an engineering analysis are the responsibility of the user. The user's engineering analysis may be qualitative or quantitative; in either case it shall be documented.~~quantitative and shall be documented.~~ Note: An engineering analysis shall not be used to accept a PRV installation that has experienced chatter.

The following is a list of topics that users may consider for their engineering analysis. Users may adjust their requirements in the engineering analysis of PRV instability based on the specific installation and service conditions.

- a) Use the applicable flowrate (rated or required) in the calculation of inlet pressure loss and built-up backpressure (see 7.3.7.3).
- b) Use the capacity that has been corrected based on the inlet pressure and outlet pressure drop, and determine if the valve is properly sized (as required in 7.3.2).
- c) Review available history to identify evidence of chatter. For example:
 - 1) Review process and process safety data to identify the history of PRV lifts.
 - 2) Compare the historical lifting events to inspection, testing, and repair records to determine if events are coincident with damage due to chatter.
 - 3) Review historical PRV inspection, testing, and repair records.
- d) Perform a force balance assessment.
 - 1) One simple method is provided here. This method adequately predicts valve stability when compared to published data^{[10][20][24][29]}. Note that the method is limited to piping systems with constant-diameter inlet lines. Valve characteristics, such as valve opening and closing times, are critical input parameters. Other more complex methods are available^{[12][20][30]}.
 - 2) The force balance uses the total inlet pressure loss, built-up backpressure, overpressure, and valve characteristics. A 10 % overpressure value is recommended for this simple force balance assessment.

The following can be used as an approximation.

- i) Conventional valves
 - If the opening pressure minus the total inlet pressure loss minus the built-up backpressure is greater than closing pressure, the PRV passes the force balance assessment. Where the blowdown value is unknown, methods exist to approximate blowdown as a function of valve characteristics^{[12][20][33]}. The total inlet pressure loss includes both the wave component (ΔP_{wave})^[20] and the frictional (non-recoverable) wave component ($\Delta P_{f,wave}$) of pressure loss.

This document is not an API Standard; it is under consideration within an API technical committee but has not received all approvals required to become an API Standard. It shall not be reproduced or circulated or quoted, in whole or in part, outside of API committee activities except with the approval of the Chairman of the committee having jurisdiction and staff of the API Standards Dept. Copyright API. All rights reserved.

The wave frictional pressure loss component is not necessarily the same in value as the non-recoverable frictional pressure loss used for applying the criteria in Section 7.3.4. Also, the non-recoverable pressure loss is expressed as a percentage of set pressure while the value used in the Equation (3) is in pressure units.

- If the inequality of Equation (3) is true, the installation passes the force balance assessment.

$P_{OPEN} - \Delta P_{f,wave} - \Delta P_{wave} - \Delta P_{built-up} > P_{CLOSE}$	(3)
--	-----

$P_{OPEN} = P_{SET} \left(1 + \frac{P_{OP}}{100} \right)$	(4)
$P_{CLOSE} = \left(1 - \frac{P_{BD}}{100} \right) P_{SET}$	(5)

where:

- P_{SET} is the set pressure of the PRV (psig);
- P_{OPEN} is the relief valve inlet pressure when open, equal to set pressure plus overpressure (psig);
- P_{CLOSE} is the closing pressure of the relief valve based on blowdown and set pressure (psig);
- ΔP_{wave} is the differential inlet wave pressure loss at 10 % overpressure (psi);
- $\Delta P_{f,wave}$ is the differential frictional wave pressure loss at 10 % overpressure (psi);
- $\Delta P_{built-up}$ is the differential built-up backpressure at 10 % overpressure (psi);
- P_{OP} is the overpressure as percentage of PRV set pressure (%) = 10 %;
- P_{BD} is the blowdown as a percentage of the PRV's set pressure (%).

ii) Balanced bellows valves

- If the total inlet pressure loss + 0.1 times built-up backpressure \leq overpressure + blowdown, the PRV passes the force balance assessment. In other words, if the inequality of Equation (6) is true, the force balance passes.

$$P_{OPEN} - \Delta P_{f,wave} - \Delta P_{wave} - 0.1 \Delta P_{built-up} > P_{CLOSE} \tag{6}$$

- The total inlet pressure loss includes both the wave component ^[20] and the frictional (non-recoverable) component of pressure loss.
- The adjustment to the built-up backpressure term recognizes the fact that the bellows area isolates a large percentage (conservatively chosen as 90 %) of the disk area from the back pressure. Note that this 0.1 multiplier is not validated by PRV stability testing, but it is a conservative and reasonable estimate.

e) Check for acoustic interaction (see 7.2.4 and Annex C).

This document is not an API Standard; it is under consideration within an API technical committee but has not received all approvals required to become an API Standard. It shall not be reproduced or circulated or quoted, in whole or in part, outside of API committee activities except with the approval of the Chairman of the committee having jurisdiction and staff of the API Standards Dept. Copyright API. All rights reserved.

7.3.7 Calculating Non-recoverable PRV Inlet Losses

7.3.7.1 General

Calculating the non-recoverable PRV inlet losses requires understanding the estimated flow rates, the fluid properties, and pipe/fitting details.

7.3.7.2 Non-recoverable Pressure Losses

Non-recoverable pressure losses are described below:

BALLOT DRAFT

This document is not an API Standard; it is under consideration within an API technical committee but has not received all approvals required to become an API Standard. It shall not be reproduced or circulated or quoted, in whole or in part, outside of API committee activities except with the approval of the Chairman of the committee having jurisdiction and staff of the API Standards Dept. Copyright API. All rights reserved.

- a) Friction losses are “non-recoverable.” Friction losses include both wall friction and turbulent dissipation for pipe and fittings (valves, reducers, expanders, etc.). Calculated friction losses shall include the entrance loss from the protected equipment. ~~The entrance loss from the protected equipment to the inlet line shall be included, as well. Consider using increased pipe roughness factors in inlet piping systems that are expected to degrade over time. Consideration should be given to using increased pipe roughness factors in inlet piping systems that are expected to degrade over time.~~
- b) When a rupture disk device is used in combination with a pressure-relief valve, the pressure-drop calculation shall include the additional pressure drop developed by the disk (see 9.1 for additional information on rupture disk devices).
- c) Kinetic energy losses are considered recoverable and do not need to be included in the pressure drop calculations.
- d) Liquid static head is recoverable and is not included in the pressure loss calculation because it is separate from the flowing pressure drop. See 7.3.3 a) for the effect of static head on set pressure.

7.3.7.3 Flow Rates for Hydraulic Calculations

A good design practice is to use the PRV rated capacity (e.g., at 10 % overpressure) for inlet pressure drop calculations, since doing so does not constrain future operations and knowledge of the valve’s modulating behavior is not required.

In applying the criteria given in 7.3.4, it is not necessary to calculate the inlet pressure drop for overpressures greater than the capacity certification overpressure. This is independent of the pressure at which the PRV provides adequate capacity. Where the allowable overpressure exceeds the capacity certification overpressure, the additional inlet pressure loss caused by the increased flow capacity due to the increased internal pressure is not expected to result in PRV instability.

The required relief rate may be used where the PRV has modulating characteristics. Modulating pilot-operated PRVs are considered to have these characteristics; pop-acting pilot-operated PRVs do not have these characteristics. Some direct spring-loaded PRVs may exhibit modulating characteristics; the valve manufacturer should be consulted for guidance on this question. The user is cautioned that valves that exhibit modulating characteristics relieving liquids may not exhibit those same characteristics relieving vapors and vice versa.

For a relief device downstream of a positive displacement pump, the required relief rate may be used provided the system is liquid full and only the pump flow will be relieved.

There are pressure-relief valve designs that can be provided with orifice areas that exceed those found in API 526^[2]. These are called full bore orifices and their area is often close to the inside diameter area of the equivalent nominal pipe size that may be used for the inlet piping. When using these types of PRVs, it is important to consider mitigation options discussed in 7.3.7.5, as 3 % loss can easily be exceeded. A modulating pilot, where required capacity may be used to calculate the pressure loss, or a remote sensing pilot as described in 7.3.9 may be used for full bore designs in order to meet 3% inlet pressure loss criterion. ~~The use of a modulating pilot, where required capacity may be used to calculate the pressure loss, or using a remote pilot sensing line as described in 7.3.9, should be considered for full bore designs.~~

When a pressure-relief valve is installed on a normally flowing process line, the 3 % limit should be applied to the sum of the loss in the normally nonflowing PRV inlet pipe and the incremental pressure loss in the process line caused by the flow through the PRV (see Figure 7).

7.3.7.4 Fluid Properties

The pressure loss calculations should consider not just the fluid properties associated with the PRV sizing case but other scenarios, as well. In particular, vapor certified PRVs sized for vapor relief, but with a liquid relief scenario, should have inlet pressure loss calculations performed for the liquid relief scenario.

This document is not an API Standard; it is under consideration within an API technical committee but has not received all approvals required to become an API Standard. It shall not be reproduced or circulated or quoted, in whole or in part, outside of API committee activities except with the approval of the Chairman of the committee having jurisdiction and staff of the API Standards Dept. Copyright API. All rights reserved.

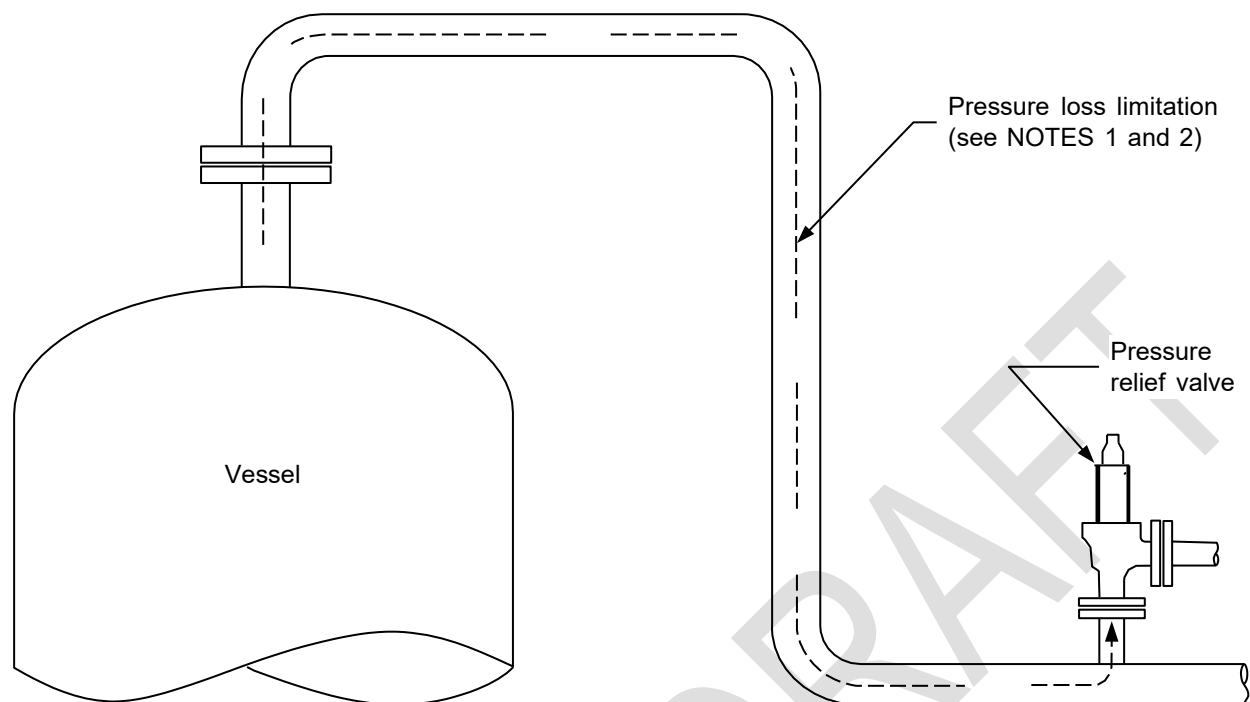

NOTE 1 See 7.3 for PRV inlet pressure drop limitations.

NOTE 2 See 7.3.7.3 for pressure loss limitations when the PRV is installed on normally flowing process piping.

Figure 7—Typical Pressure-relief Valve Mounted on Process Line

7.3.7.5 Design Options to Address High Inlet Pressure Drop

Pressure losses can be reduced by making modifications to the system design, including but not limited to the following:

- rounding the entrance to the inlet piping;
- reducing the inlet line length;
- reducing the number of fittings;
- installing a different type of fitting (i.e. lower equivalent length);
- increasing the diameter of the inlet piping (see Figure 8);
- ensuring that the relief capacity is well-matched to the required rate; one option is to use a restricted lift PRV (consult manufacturer) to reduce rated capacity of the valve^[26]; or
- using multiple PRVs; provide one smaller valve with independent inlet piping for low-flow contingencies.

An option for mitigating excessive inlet losses is to use a pilot-operated relief valve with remote sensing (see 7.3.9) if the application permits.

This document is not an API Standard; it is under consideration within an API technical committee but has not received all approvals required to become an API Standard. It shall not be reproduced or circulated or quoted, in whole or in part, outside of API committee activities except with the approval of the Chairman of the committee having jurisdiction and staff of the API Standards Dept. Copyright API. All rights reserved.

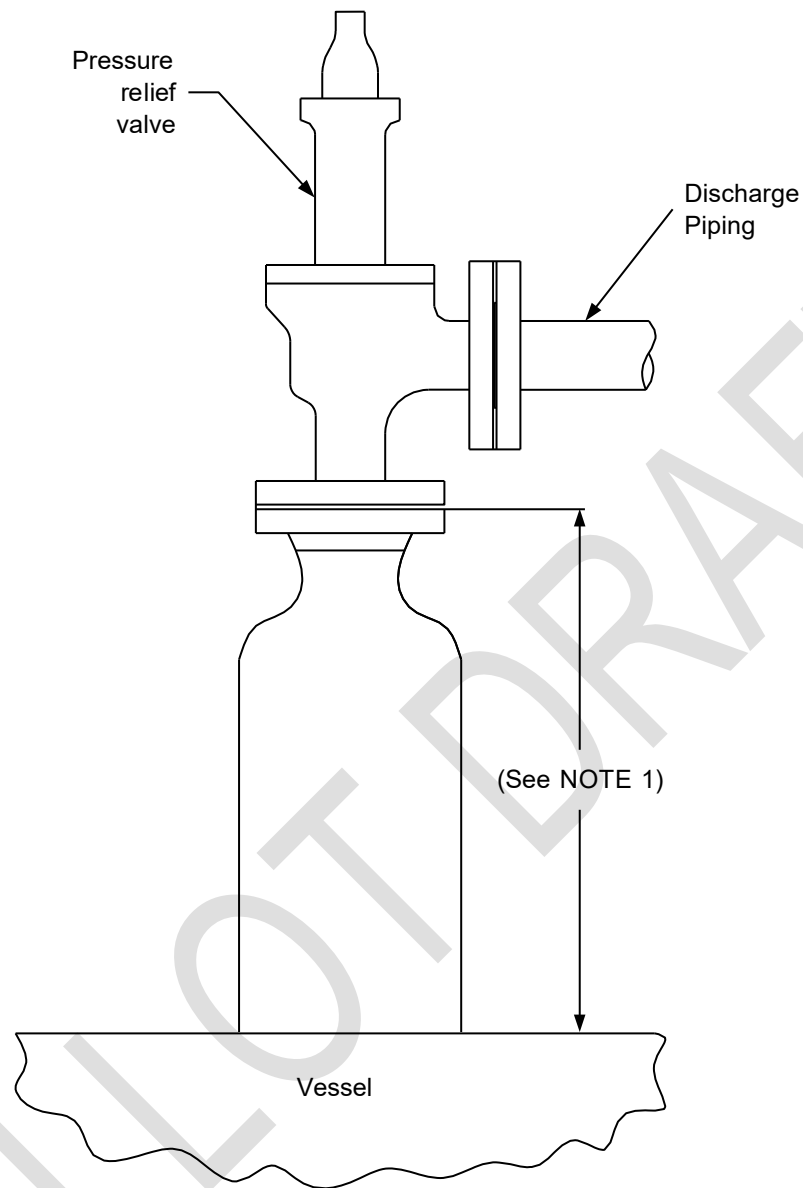

NOTE 1 See 7.3 for PRV inlet pressure drop limitations.

Figure 8—Typical Pressure-relief Valve Mounted on Long Inlet Pipe

7.3.8 Inlet Loss Criteria for Thermal Relief Valves

The inlet piping for thermal relief valves designed solely to protect against liquid hydraulic expansion due to ambient heating (including solar radiation) typically does not need to be sized to meet the inlet loss requirements of 7.3.4. The reason for this is that the rated capacity of these pressure-relief valves is larger by an order of magnitude (>10 times) than the required relief rate and the flow in the inlet line never reaches a steady state flow at the rated capacity.

Some examples where inlet pressure drop calculations for thermal expansion generated by ambient heating should be evaluated are applications (e.g., long pipelines or large liquid-filled vessels) where the required flow rate due to thermal expansion approaches the rated capacity of the valve. An example where inlet pressure drop calculations for thermal expansion generated by ambient heating should be considered is applications

This document is not an API Standard; it is under consideration within an API technical committee but has not received all approvals required to become an API Standard. It shall not be reproduced or circulated or quoted, in whole or in part, outside of API committee activities except with the approval of the Chairman of the committee having jurisdiction and staff of the API Standards Dept. Copyright API. All rights reserved.

~~(e.g. long pipelines or large liquid-filled vessels) where the required flow rate due to thermal expansion approaches the rated capacity of the valve.~~ The user is cautioned that for liquids (e.g. refrigerated liquids, LPG, or LNG) where blocking in with ambient heating may lead to vaporization within the protected system and possible overpressure (not solely liquid expansion), required relief rates may be large enough to warrant inlet pressure drop calculations.

BALLOT DRAFT

This document is not an API Standard; it is under consideration within an API technical committee but has not received all approvals required to become an API Standard. It shall not be reproduced or circulated or quoted, in whole or in part, outside of API committee activities except with the approval of the Chairman of the committee having jurisdiction and staff of the API Standards Dept. Copyright API. All rights reserved.

The user is cautioned that some applications of thermal expansion due to process heating, such as heat exchangers or equipment that is exposed to heat tracing, can have significantly more heat transfer, and the inlet pressure drop should be evaluated (see 7.3.4).

~~For thermal relief valves that can open as a result of being connected to a system that has other credible overpressure scenarios, the inlet piping to the valve should meet the inlet loss requirements of 7.3.4 for those scenarios. For thermal relief valves that can open as a result of being connected to a system that has other credible overpressure scenarios, the user is cautioned that the inlet piping to the valve should be designed to meet the inlet loss requirements of 7.3.4 for those scenarios.~~

Note that inlet piping for thermal relief devices shall **always** be sized to meet the inlet loss requirements of 7.3.4 for applications where pressure inside the protected equipment can be generated by process heat.

Examples of these applications include:

- a) cold side of heat exchangers when blocked in and exposed to hot side fluid temperature;
- b) heat-traced piping or vessels where the tracing can vaporize blocked-in liquid at relieving conditions.

7.3.9 Inlet Loss Criteria for Remote Sensing for Pilot-Operated Pressure-Relief Valves

Remote sensing permits the pilot to sense system pressure at a location that most accurately reflects the actual pressure of the protected system. Remote sensing will mitigate the effect of excessive inlet pressure losses due to the inlet piping configuration (see Figure 9). The addition of a remote sensing line allows the pilot to correctly sense system pressure and to keep the valve from rapid cycling or chattering due to high inlet piping pressure losses.

This document is not an API Standard; it is under consideration within an API technical committee but has not received all approvals required to become an API Standard. It shall not be reproduced or circulated or quoted, in whole or in part, outside of API committee activities except with the approval of the Chairman of the committee having jurisdiction and staff of the API Standards Dept. Copyright API. All rights reserved.

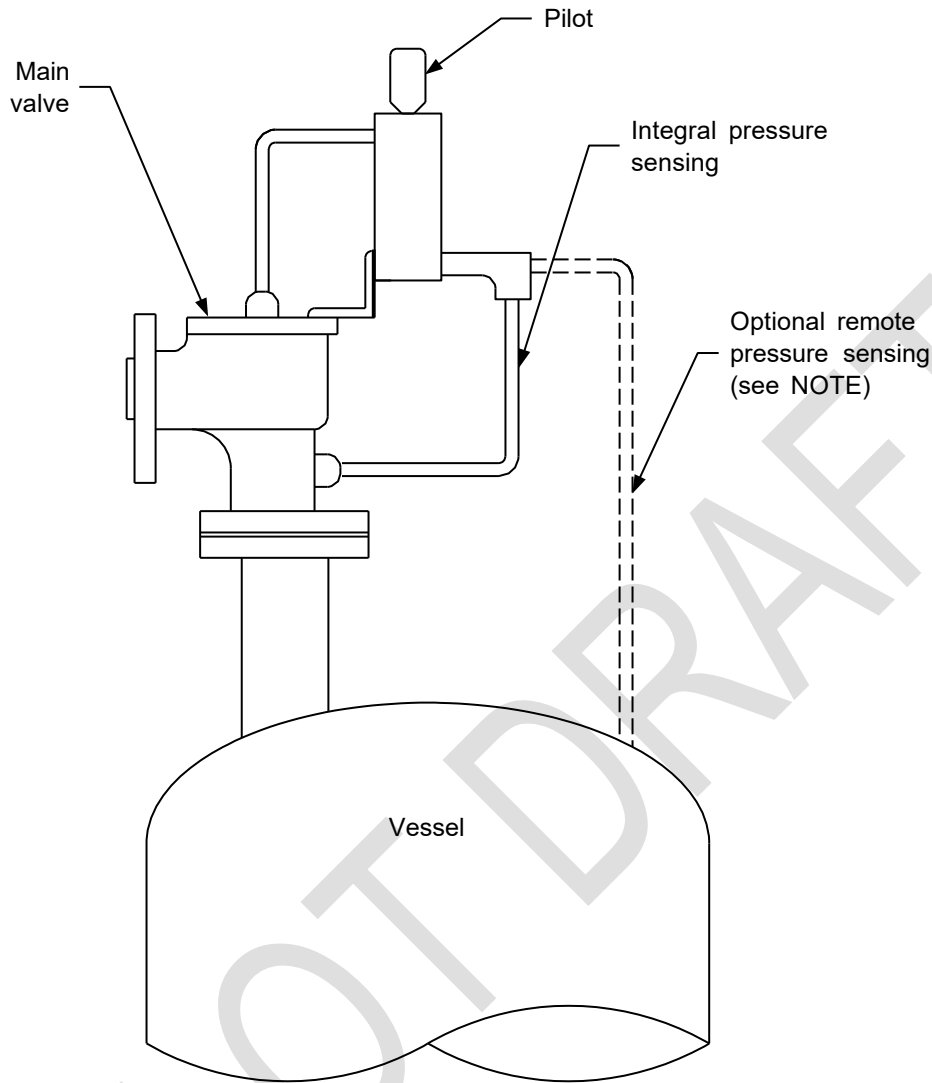

NOTE See 7.3.9.

Figure 9—Typical Pilot-Operated Pressure-relief Valve Installation

Although remote sensing may eliminate valve chatter or permit a modulating pilot-operated pressure-relief valve to achieve full lift at the required overpressure, any pressure drop in the inlet pipe will reduce the relieving capacity (see 7.3.2).

Installation guidelines for remote sensing lines are as follows.

- Remote sensing lines should measure static pressure where the velocity is low. Otherwise, the pilot will sense an artificially low pressure due to the effect of velocity.
- Ensure that the pilot sensing point is within the system protected by the main valve.
- For flowing pilots, remote sensing lines shall be sized to limit the pressure loss to 3 % of the set pressure based on the maximum flow rate of the pilot at 110 % of set pressure. Consult the manufacturer for the flow rate of the pilot. Consult the manufacturer for size recommendations for the remote sensing line.

This document is not an API Standard; it is under consideration within an API technical committee but has not received all approvals required to become an API Standard. It shall not be reproduced or circulated or quoted, in whole or in part, outside of API committee activities except with the approval of the Chairman of the committee having jurisdiction and staff of the API Standards Dept. Copyright API. All rights reserved.

- d) For nonflowing pilots, remote sensing lines with a flow area of 0.070 in.² (45 mm²) ~~should be~~ are typically sufficient since no system medium flows through this type of pilot when the main valve is open and relieving. Consult the manufacturer for size recommendations for the remote sensing line.
- e) Consider using pipe for remote sensing lines to ensure mechanical integrity. Additionally, The user should select materials compatible with the process fluid when selecting material of construction for the sensing line. ~~corrosion resistance should be considered when selecting material of construction for the sensing line.~~
- f) If a block valve is installed in the remote sensing line, the guidelines in Section 8 should be followed. A closed block valve in a remote sensing line renders the pilot valve inoperative and may allow the main valve to open.
- g) Purge systems for remote and integral sensing lines may be required for certain applications prone to plugging. Special considerations are required if purge systems are used. In particular, the ~~reliability of~~ the purge flow should be from a reliable source ensured. The manufacturer should be consulted for additional recommendations.

8 PRD Isolation (Stop) Valves

8.1 General

Isolation block valves may be used for maintenance purposes to isolate a PRD from the equipment it protects or from its downstream disposal system. Since improper use of an isolation valve may render a PRD inoperative, the design, installation, and administrative controls placed on these isolation block valves are important. Detailed requirements are discussed below. ~~Since improper use of an isolation valve may render a PRD inoperative, the design, installation, and administrative controls placed on these isolation block valves should be carefully evaluated to ensure that plant safety is not compromised.~~

A PRD shall not be used as a block valve to provide positive isolation.

8.2 Application

If a PRD has a service history of leakage, plugging, or other severe problems that affect its performance, isolation and sparing of the PRD may be provided. The use of isolation valves and/or sparing permits the PRD to be inspected, maintained, or repaired without shutting down the process unit. However, there are potential hazards associated with the use of isolation valves. The ASME *Boiler and Pressure Vessel Code*, Section ~~VIII-XIII~~ [7], Nonmandatory Appendix MB, Section MB-5, B-6, B-7 and B-8-5.6 discusses proper application of these valves and the administrative controls that shall be in place when isolation block valves are used. Local jurisdictions may have other requirements.

Additional examples of isolation valve installations are given in 8.4.

8.3 Isolation Valve Requirements

8.3.1 General

Isolation (stop) valves are allowed upstream and/or downstream of the pressure-relieving device for the purpose of inspection, testing, and repair of the pressure-relieving device or discharge header isolation.

~~In addition to previously noted inlet and outlet pressure drop restrictions, isolation valves located in relief system piping shall meet the requirements specified below.~~

The opening through ~~all pipe and fittings (including stop valves)~~ between a pressure vessel and its PRV shall have at least the area of the PRV inlet connection (see 5.2).

For outlet isolation valves, to help minimize the built-up backpressure, the flow area in the outlet isolation

This document is not an API Standard; it is under consideration within an API technical committee but has not received all approvals required to become an API Standard. It shall not be reproduced or circulated or quoted, in whole or in part, outside of API committee activities except with the approval of the Chairman of the committee having jurisdiction and staff of the API Standards Dept. Copyright API. All rights reserved.

valve should be equal to or greater than the outlet area of the PRV.

BALLOT DRAFT

This document is not an API Standard; it is under consideration within an API technical committee but has not received all approvals required to become an API Standard. It shall not be reproduced or circulated or quoted, in whole or in part, outside of API committee activities except with the approval of the Chairman of the committee having jurisdiction and staff of the API Standards Dept. Copyright API. All rights reserved.

Butterfly valves and globe valves are not full area due to the presence of internal elements, and typically are not designed for tight shut-off. In addition, there is the potential for internal failure of the butterfly valve, causing an obstruction in the PRD inlet line. For these reasons, butterfly valves and globe valves should not be used as PRD isolation valves.

While butterfly valves are not recommended for usage as PRD isolation valves, high-performance butterfly valves can be suitable for isolating large relief headers. Butterfly valves used for these applications should be specified to ensure that the disk will not fail in a position that will restrict flow and that provides a tight shut-off. ~~Butterfly valves used for these applications should be specified to a rigorous set of standards that ensure that the disk will not fail in a position that will restrict flow and that provides a tight shut-off.~~

Check valves shall not be installed in PRD inlet or outlet lines since these devices are normally closed and the check valve can become stuck in the closed position or fail in a manner causing an obstruction in the PRD path.

8.3.2 Inlet and Outlet Isolation Valves

For PRD inlet and outlet isolation valves:

- a) Valves shall be suitable for the line service classification.
- b) Valves shall have the capability of being locked or car-sealed in the appropriate position.
- c) When gate valves are used, they shall be installed with stems oriented horizontally or, if this is not feasible, the stem shall be oriented downward to a maximum of 45° from the horizontal to keep the gate from falling off and blocking the flow.
- d) A bleed valve shall be installed between the isolation valve and the PRD to enable the system to be safely depressurized prior to performing maintenance. This bleed valve can also be used to prevent pressure buildup between the PRD and the closed outlet isolation valve.
- e) The outlet isolation valve should ~~never-not~~ be closed while the vessel is in operation without using an inlet isolation valve that has first been closed with the space between the inlet isolation valve and the PRV adequately depressurized. If the PRV inlet pressure is higher than the design pressure of the PRV body or bellows, closure of the discharge valve could lead to PRV component overpressure. Procedures or work practices can be used to facilitate proper sequencing; however, consideration might also be given to using an interlocking system between the inlet and outlet isolation valves to assist with proper sequencing. These work practices or procedures can apply to relief device isolation valves in general.
- f) ~~Consideration should be given to painting the isolation valve a special color or providing other identification.~~

When placing the PRD into service, any outlet valve should be opened fully before beginning to open the inlet valve. Isolation valves should be opened gradually to help prevent unwanted opening of a PRD due to the momentum of the fluid. The inlet and outlet isolation valves shall be open fully whenever the PRV is in service. A typical installation of inlet and outlet isolation valves for PRVs is shown in Figure 10. A typical installation of inlet and outlet isolation valves for 100 % sparing applications is shown in Figure 11, with an alternate installation shown in Figure 12 (see 8.3.3 for discussion on 100 % spare relief capacity).

8.3.3 Installation of Spare Relief Capacity

In corrosive and fouling services, or other services which may require frequent PRD inspection and testing, an additional relief device should be installed, so that 100 % design relieving capacity is available while any PRD is out of service. Examples of this type of installation are shown in Figure 11, Figure 12, and Figure 13. The spare PRVs may be stored until needed, to preserve their integrity and allow bench testing just prior to installation. ~~In corrosive and fouling services, or other services that may require frequent PRD inspection and testing, consideration should be given to the installation of an additional relief device, so that 100 %~~

This document is not an API Standard; it is under consideration within an API technical committee but has not received all approvals required to become an API Standard. It shall not be reproduced or circulated or quoted, in whole or in part, outside of API committee activities except with the approval of the Chairman of the committee having jurisdiction and staff of the API Standards Dept. Copyright API. All rights reserved.

~~design relieving capacity is available while any PRD is out of service. An example of a typical installation is shown in Figure 11, and Figure 12 provides an example of an alternate installation. Typical examples of the types of isolation valves used for sparing applications are provided in Figure 13, Figure 14, and Figure 15. Consideration should be given to storing the spare PRVs until needed, to preserve their integrity and allow bench testing just prior to installation.~~

BALLOT DRAFT

This document is not an API Standard; it is under consideration within an API technical committee but has not received all approvals required to become an API Standard. It shall not be reproduced or circulated or quoted, in whole or in part, outside of API committee activities except with the approval of the Chairman of the committee having jurisdiction and staff of the API Standards Dept. Copyright API. All rights reserved.

When spare relief devices are provided, a mechanical interlock or administrative controls shall be provided to manage proper opening and closing sequences of the isolation valves to ensure that overpressure protection of the vessel or equipment is not compromised.

Typically, the inlet isolation valves for spare relief devices are closed and the outlet isolation valves are open. The outlet isolation valve for spare relief devices can be closed during operation if exposure to the fluid is a concern; however, the pressure temperature rating of the PRD outlet, the outlet isolation valve, and intervening piping should be suitable for the conditions upstream of the relief device in case of leakage. Protection of the PRD from discharge system fluids without closing the outlet isolation valve can also be achieved either by providing a purge or by installing a discharge rupture disk.

Three-way changeover valves are acceptable in spare relief capacity applications provided the installation meets the size and inlet pressure drop requirements (see 8.3.4).

BALLOT DRAFT

This document is not an API Standard; it is under consideration within an API technical committee but has not received all approvals required to become an API Standard. It shall not be reproduced or circulated or quoted, in whole or in part, outside of API committee activities except with the approval of the Chairman of the committee having jurisdiction and staff of the API Standards Dept. Copyright API. All rights reserved.

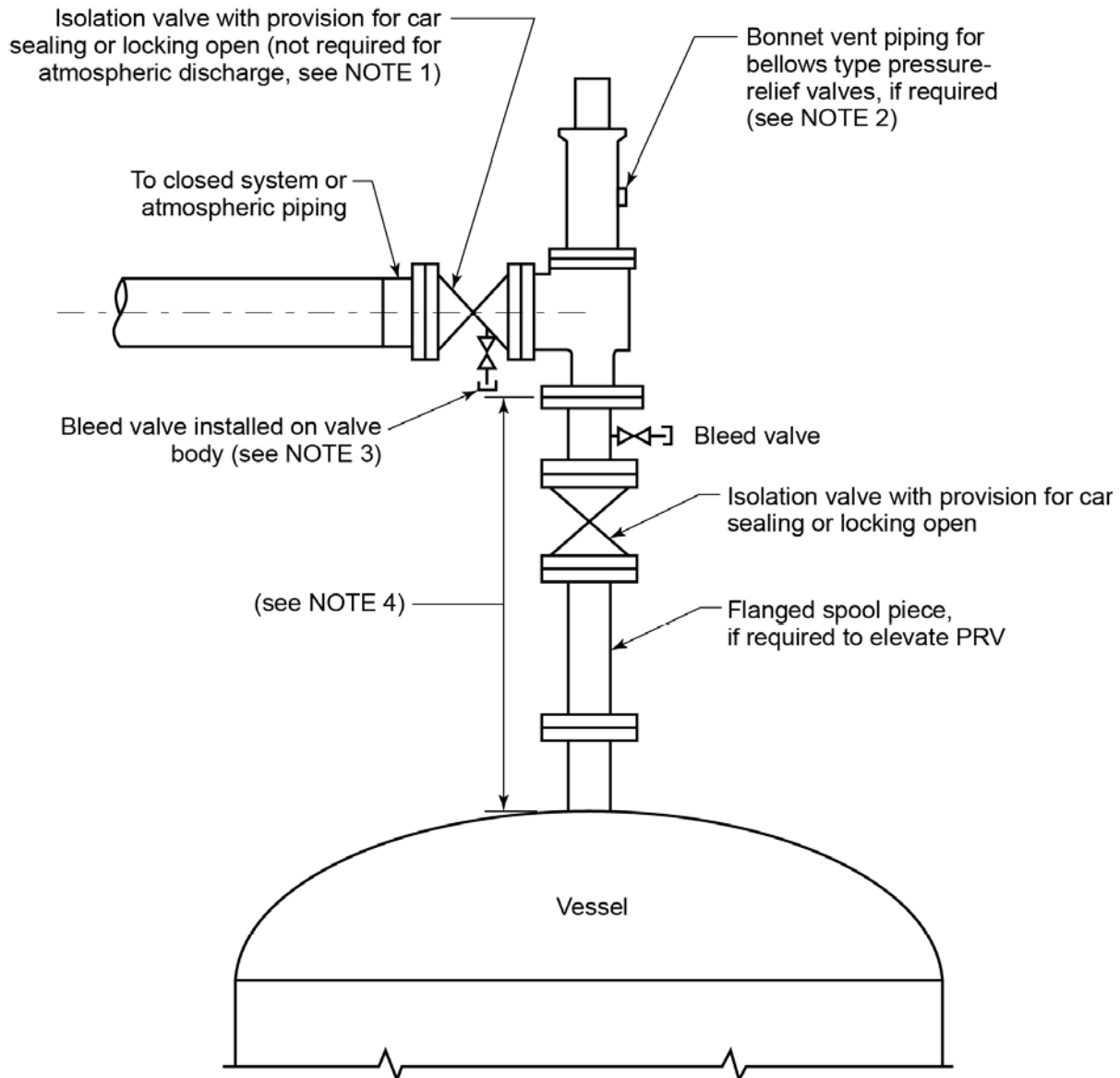

NOTE 1 See Section 8 for the use of isolation valves in pressure-relief system piping.

NOTE 2 See Section 10.

NOTE 3 Alternatively, a pipe spool with bleed may be provided.

NOTE 4 See 7.3 for PRV inlet pressure drop limitations.

Figure 10—Typical PRD Installation with an Isolation Valve

This document is not an API Standard; it is under consideration within an API technical committee but has not received all approvals required to become an API Standard. It shall not be reproduced or circulated or quoted, in whole or in part, outside of API committee activities except with the approval of the Chairman of the committee having jurisdiction and staff of the API Standards Dept. Copyright API. All rights reserved.

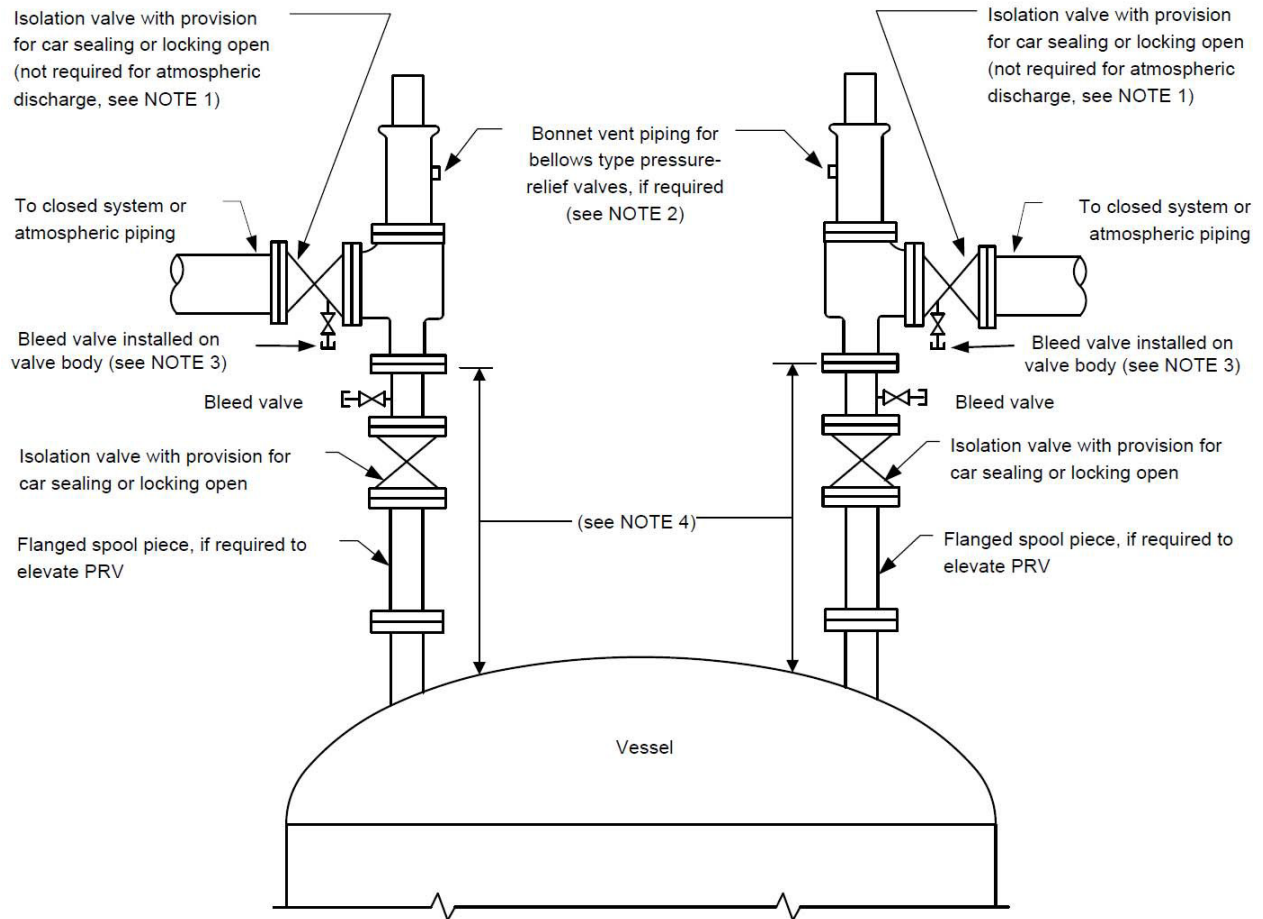

- NOTE 1 See Section 8 for the use of isolation valves in pressure-relief system piping.
- NOTE 2 See Section 10.
- NOTE 3 Alternatively, a pipe spool with bleed may be provided.
- NOTE 4 See 7.3 for detailed discussion on inlet pressure drop.

Figure 11—Typical PRD Installation for 100% Spare Relieving Capacity

This document is not an API Standard; it is under consideration within an API technical committee but has not received all approvals required to become an API Standard. It shall not be reproduced or circulated or quoted, in whole or in part, outside of API committee activities except with the approval of the Chairman of the committee having jurisdiction and staff of the API Standards Dept. Copyright API. All rights reserved.

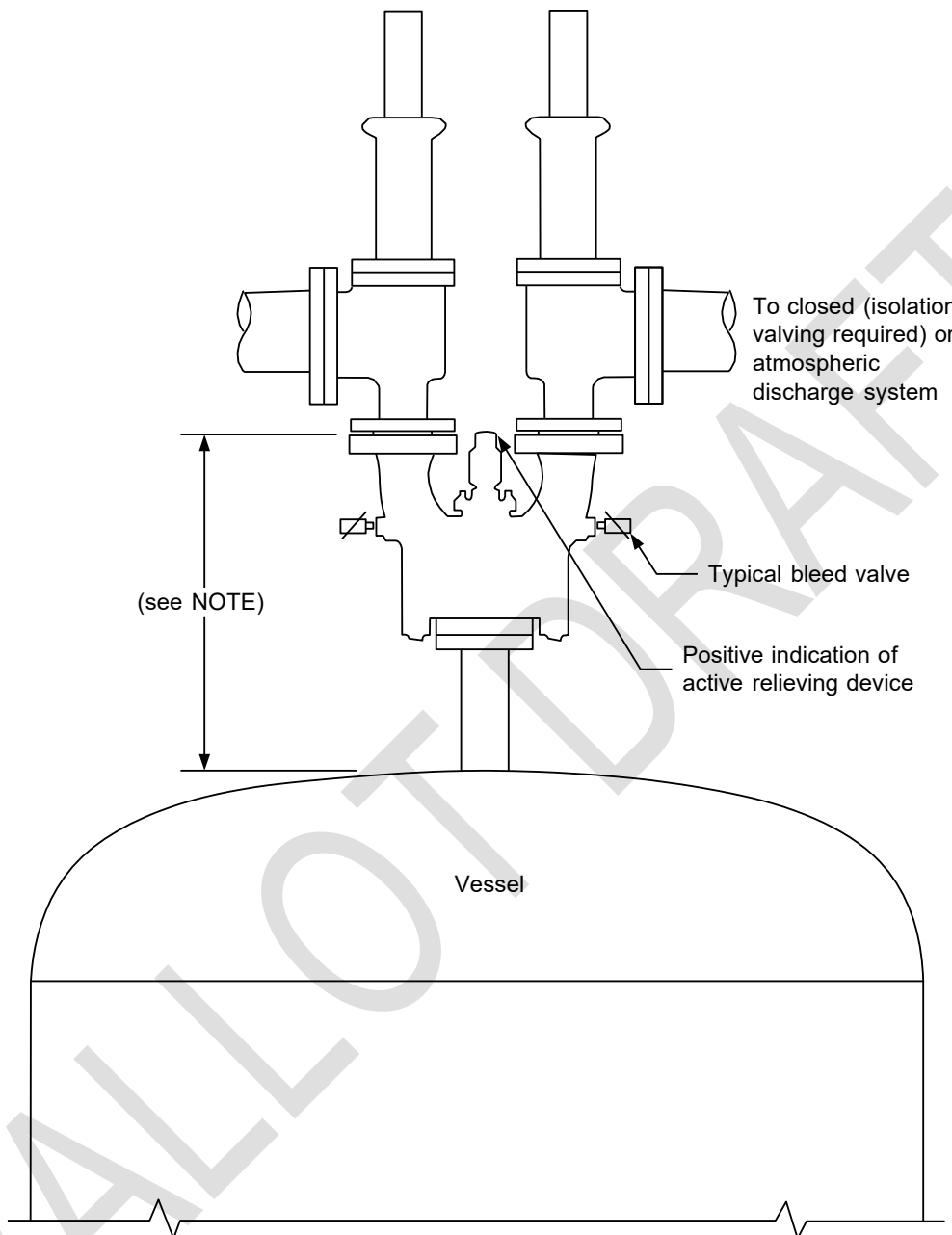

NOTE See 7.3 for PRV inlet pressure drop limitations.

Figure 12—Alternate PRD Installation for 100 % Spare Relieving Capacity

8.3.4 Three-Way Changeover Valves for Dual PRD Installations

Three-way changeover valves are available that are designed specifically for isolation valve service of dual PRD installations. Such installations provide 100 % of the design relieving capacity with one PRD while a relief device is out of service. The second PRD may be permanently mounted on the three-way changeover valve or may be stored until needed to preserve its integrity and allow bench testing just prior to installation. Three types of changeover valves are available: the shuttle type (see Figure 13), the rotor type (see Figure 14), and a three-way ball valve combined with piping on the inlet and outlet (see Figure 15).

This document is not an API Standard; it is under consideration within an API technical committee but has not received all approvals required to become an API Standard. It shall not be reproduced or circulated or quoted, in whole or in part, outside of API committee activities except with the approval of the Chairman of the committee having jurisdiction and staff of the API Standards Dept. Copyright API. All rights reserved.

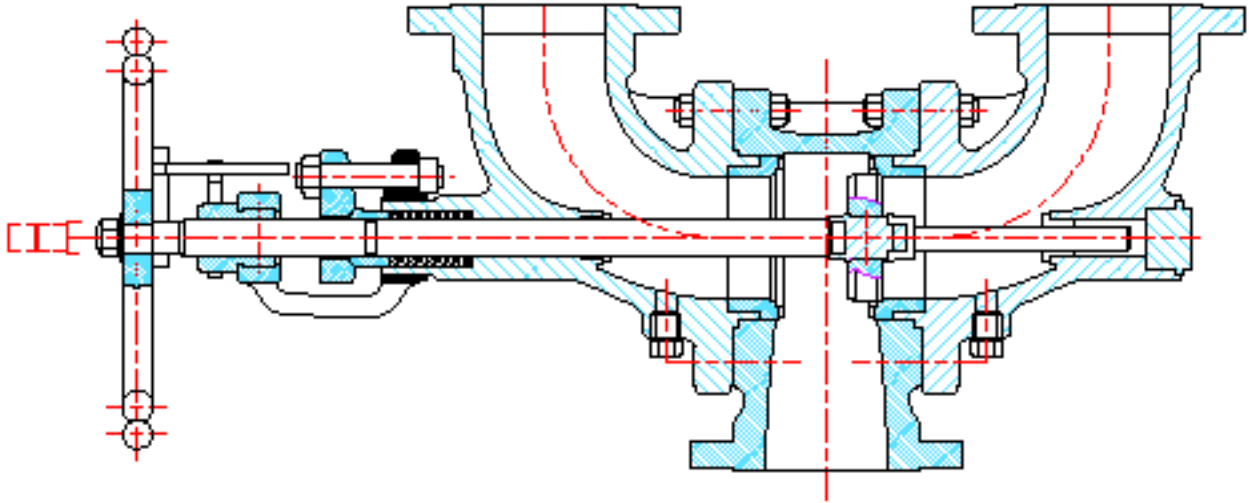

Figure 13—Three-Way Changeover Valve—Shuttle Type

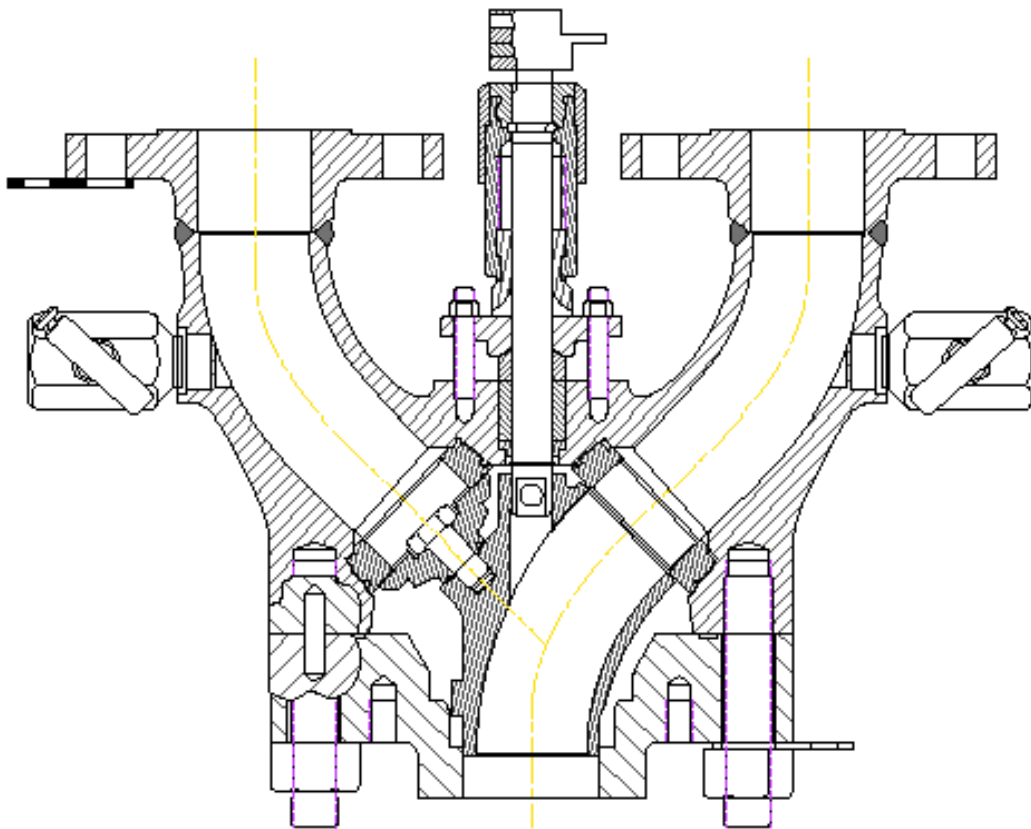

Figure 14—Three-Way Changeover Valve—Rotor Type

- a) Three-way changeover valves, used for PRV installations, shall be sized to ensure compliance with the inlet loss requirements of 7.3.4. Some three-way changeover valves are designed with minimum flow areas equal to or greater than the inlet area of a PRV designed for that line size. Other designs, however, may have to be specified one line size larger than the PRV to minimize inlet pressure losses.
- b) The three-way changeover valve should be designed to prevent both PRDs from being isolated at any time during its switchover operation.
- c) A positive indication of which PRD is active ~~should~~ shall be a required accessory for the three-way changeover valve.
- d) A bleed valve shall be installed between the inlet isolation valve and ~~an isolated~~ the PRD to enable the inlet to the isolated PRV to be safely depressurized prior to performing maintenance.
- e) Individual isolation valves may be used on the outlet side of PRDs that are mounted on an inlet three-way changeover. ~~When using individual outlet isolation valves, the recommendations of See 8.3.2 should be followed for guidance on outlet isolation valves.~~
- f) Three-way valves may also be used for outlet isolation. Designs are available that will minimize the effects of built-up backpressure when using the same pipe size as the outlet of the pressure-relieving device. ~~All other recommendations of 8.3.2 should be followed~~ See 8.3.2 for guidance on outlet isolation valves.
- g) Isolation valves shall have the capability of being locked or car-sealed in position. Only an authorized person may break the seal and operate the valve; see 8.5. Mechanical interlocks and/or ~~management~~ administrative control procedures shall be provided that will ensure the proper opening and closing sequences of the inlet and outlet isolation valves.

8.3.5 Use of Ball Valves as Three-Way Changeover Valve

Ball valves are available in a variety of configurations, as shown in Figure 15. The two seat L-port configuration is the most commonly used configuration for relief device selector service. Due to the variety of configurations, caution should be taken so that the proper configuration is specified, the ports properly marked, and the valve properly installed.

8.4 Examples of Isolation Valve Installations

An isolation valve downstream of a PRD may be installed at battery limits of process units (see Figure 16). The purpose of battery limit isolation valves is to allow process units to be removed from service for maintenance while other process units discharging into the main plant flare header remain in service. Similarly, relief system isolation valves may be used for equipment such as compressors, dryers, or coalescers, which are spared and need to be shut down for maintenance while spare equipment remains online (see Figure 17).

This document is not an API Standard; it is under consideration within an API technical committee but has not received all approvals required to become an API Standard. It shall not be reproduced or circulated or quoted, in whole or in part, outside of API committee activities except with the approval of the Chairman of the committee having jurisdiction and staff of the API Standards Dept. Copyright API. All rights reserved.

Number of seats	2	4	4
Port arrangements	<p>3-Way "L" port</p> 	<p>3-Way "L" port</p>  <p>3-Way "T" port</p> 	

Figure 15—Three-Way Changeover Valve—Ball Types

8.5 Administrative Controls Related to Isolation Valves

Administrative controls shall be in place that will prohibit the inappropriate closing of isolation valves in pressure-relief system piping. These controls shall require that the opening and closing of the isolation valves be done by a trained person.

An updated list shall be kept of all isolation valves located in pressure-relief system piping which could isolate PRVs. Documentation of the required position for the lock or seal should be provided.

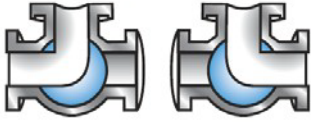
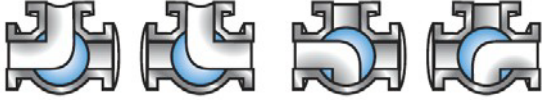
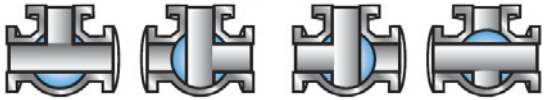
Periodic inspections of isolation valves located in pressure-relief system piping shall be made which verify the position of isolation valves and the condition of the locking or sealing device. Administrative controls shall be in place that will prohibit the inappropriate closing of isolation valves in pressure-relief system piping. These controls should require that the opening and closing of the isolation valves be done by an authorized person.

An updated list should be kept of all isolation valves located in pressure-relief system piping that could isolate PRVs. Documentation of the required position and a reason for the lock or seal should be provided.

Periodic inspections of isolation valves located in pressure-relief system piping should be made that verify the position of isolation valves and the condition of the locking or sealing device.

This document is not an API Standard; it is under consideration within an API technical committee but has not received all approvals required to become an API Standard. It shall not be reproduced or circulated or quoted, in whole or in part, outside of API committee activities except with the approval of the Chairman of the committee having jurisdiction and staff of the API Standards Dept. Copyright API. All rights reserved.

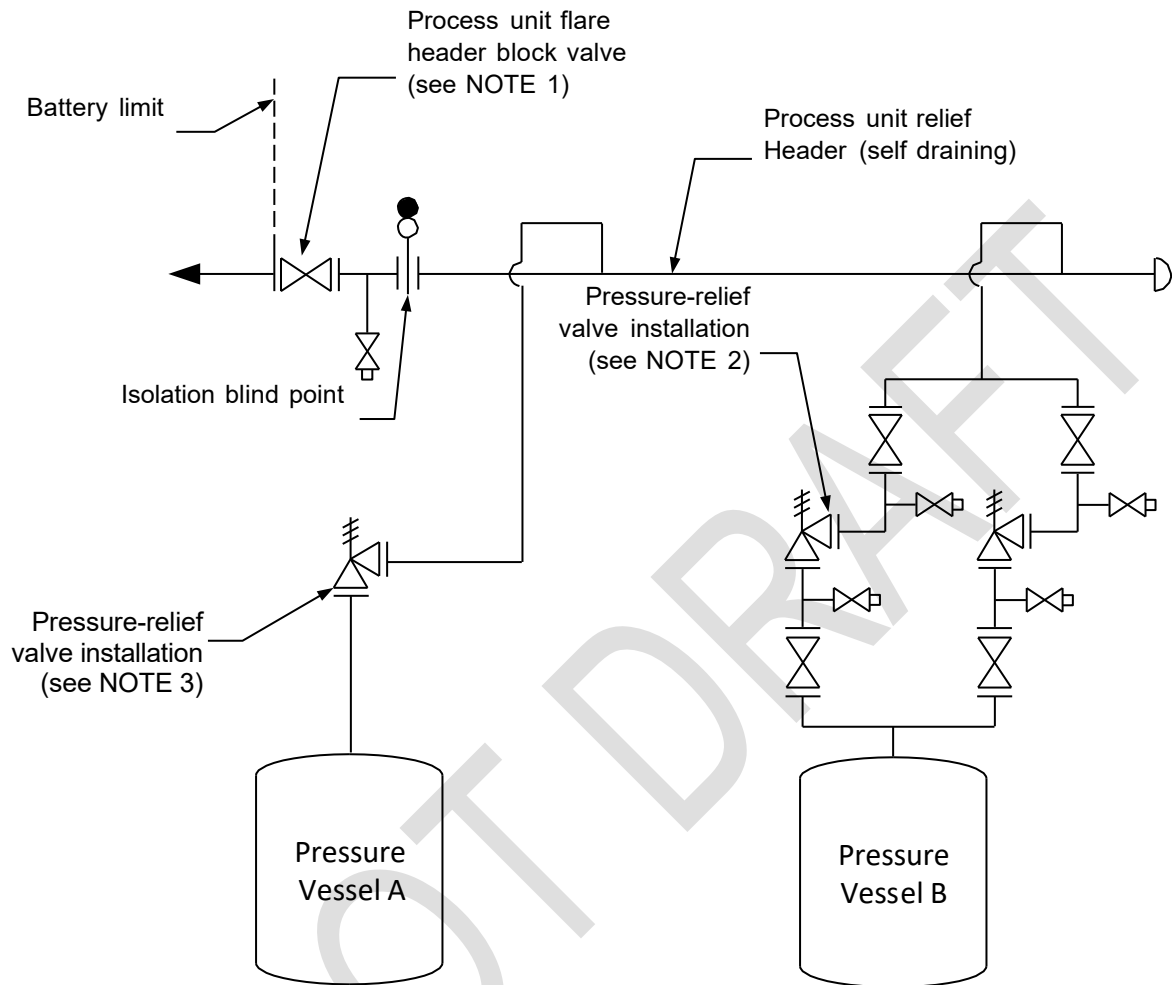

- NOTE 1 See 8.4.
NOTE 2 See Figure 11 and Figure 12.
NOTE 3 See Figure 3 and Figure 10.

Figure 16—Typical Flare Header Block Valves

This document is not an API Standard; it is under consideration within an API technical committee but has not received all approvals required to become an API Standard. It shall not be reproduced or circulated or quoted, in whole or in part, outside of API committee activities except with the approval of the Chairman of the committee having jurisdiction and staff of the API Standards Dept. Copyright API. All rights reserved.

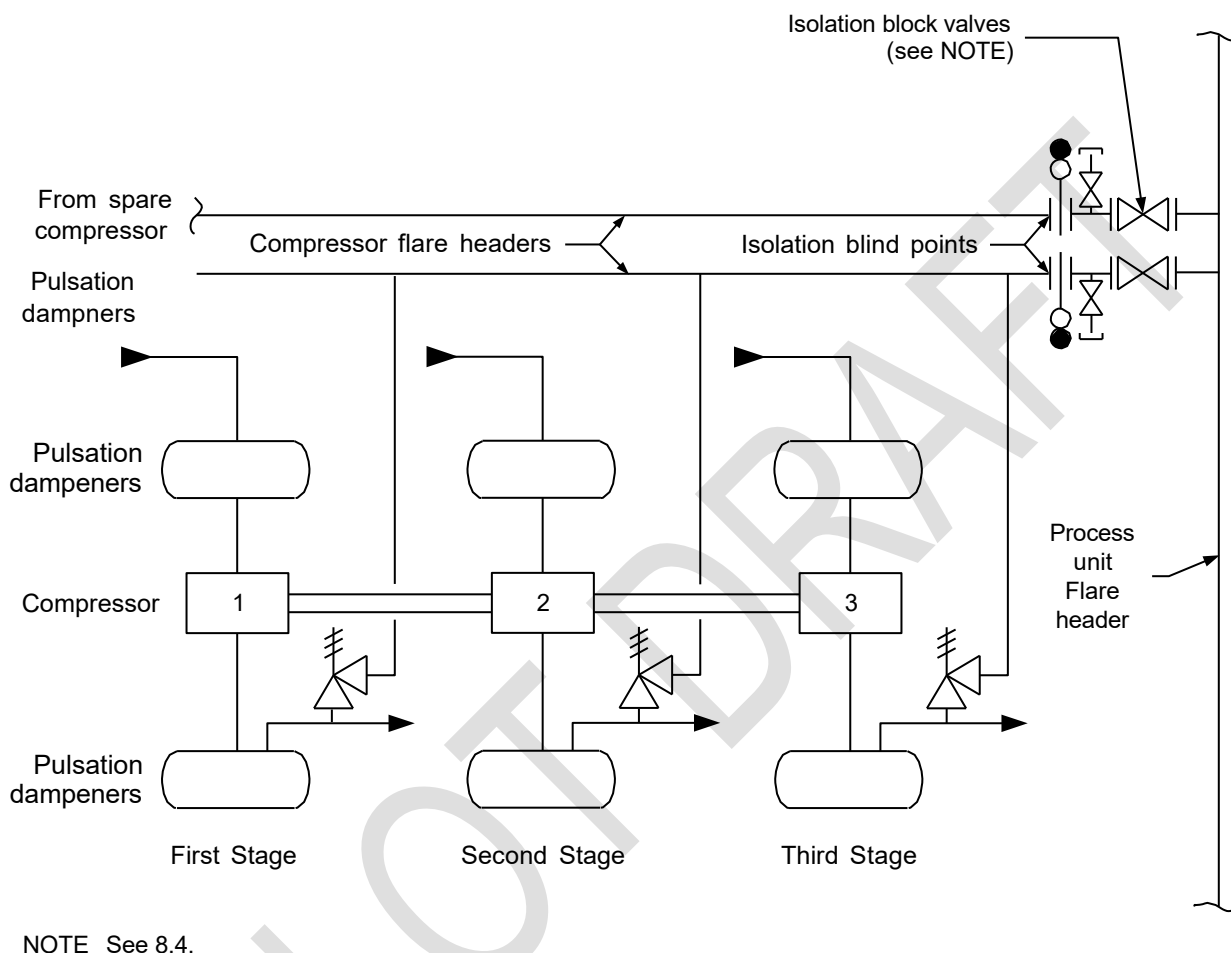

Figure 17—Typical Isolation Block Valves for Spare Compressor

9 Rupture Disk Installations

9.1 Rupture Disk Devices in Combination with PRVs

A rupture disk device may be used as the sole PRD, or it may be installed between a PRV and the vessel (see Figure 18) or on the downstream side of a PRV.

Only nonfragmenting rupture disk devices should be used on the inlet side of Fragmenting rupture disk devices shall not be used upstream of a pressure-relief valve. Users are warned that a rupture disk will not burst within its tolerance if backpressure builds up in a non-vented space between the rupture disk and the pressure-relief valve, which will occur if leakage through the rupture disk develops due to corrosion or another cause. When a rupture disk device is used between the PRV and the protected vessel, the space between the rupture disk and the PRV shall have a free vent, pressure gauge, trycock, or other suitable telltale indicator. A short spool piece is often installed between the rupture disk and the PRV for this purpose. A non-vented space with a pressure gauge without alarms or other indication devices is not recommended as a suitable telltale indicator, unless there are administrative controls to ensure that there is no accumulation of pressure between the disk and the valve.

This document is not an API Standard; it is under consideration within an API technical committee but has not received all approvals required to become an API Standard. It shall not be reproduced or circulated or quoted, in whole or in part, outside of API committee activities except with the approval of the Chairman of the committee having jurisdiction and staff of the API Standards Dept. Copyright API. All rights reserved.

Rupture disks may not be available in all sizes at lower pressures; therefore, for these low-pressure applications, the available rupture disk may have to be larger than the nominal size of the inlet piping and PRV.

BALLOT DRAFT

This document is not an API Standard; it is under consideration within an API technical committee but has not received all approvals required to become an API Standard. It shall not be reproduced or circulated or quoted, in whole or in part, outside of API committee activities except with the approval of the Chairman of the committee having jurisdiction and staff of the API Standards Dept. Copyright API. All rights reserved.

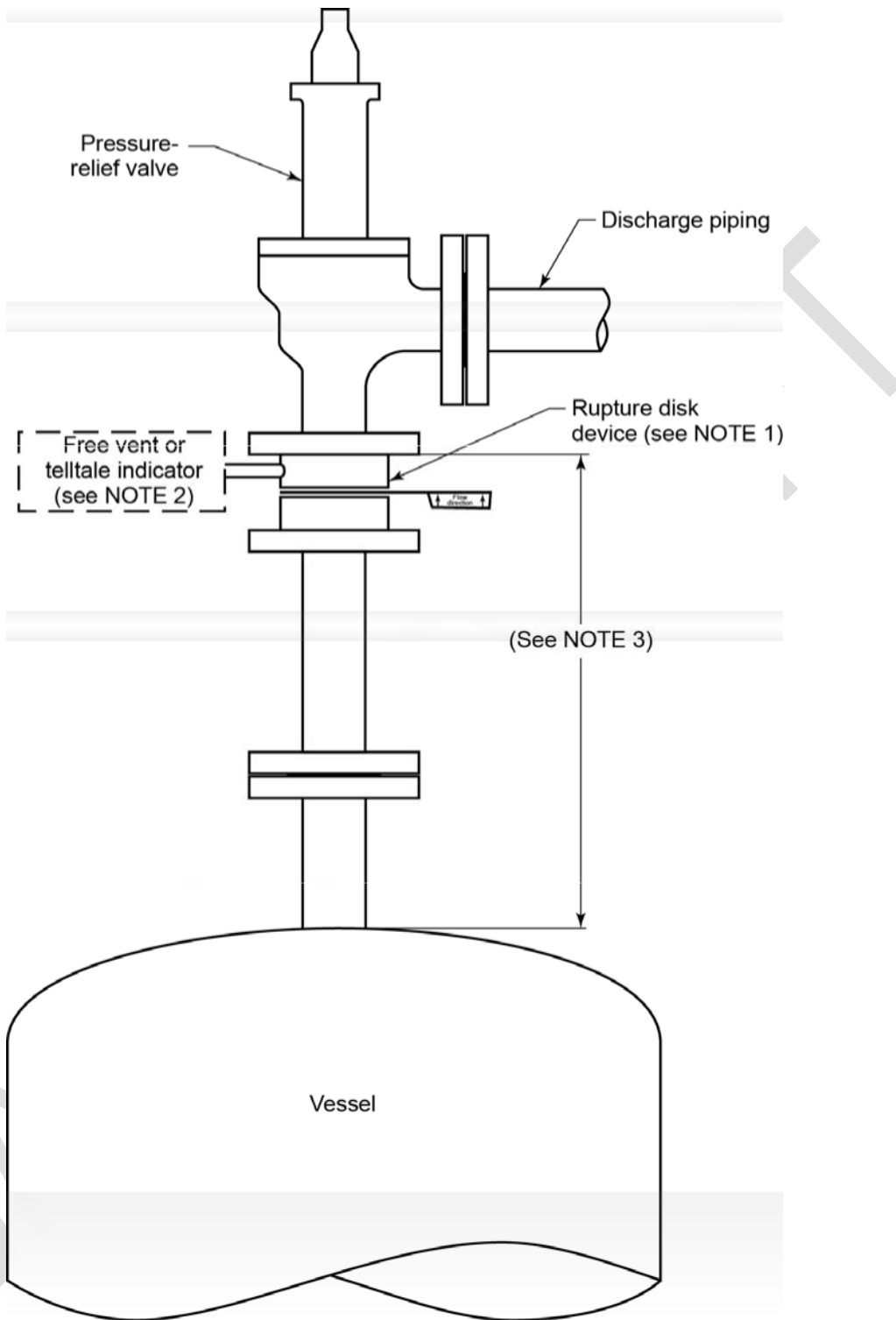

NOTE 1 Non-fragmenting rupture disk design.

NOTE 2 ~~The space between the rupture disk and PRV shall be vented or provided with a suitable telltale indicator. A short spool piece is often installed between the rupture disk and the PRV for this purpose.~~ See 9.1 for additional guidelines.

NOTE 3 See 7.3 for PRV inlet pressure loss limitations.

Figure 18—Typical Rupture Disk Device in Combination With Relief Valve: Inlet Side Installation

This document is not an API Standard; it is under consideration within an API technical committee but has not received all approvals required to become an API Standard. It shall not be reproduced or circulated or quoted, in whole or in part, outside of API committee activities except with the approval of the Chairman of the committee having jurisdiction and staff of the API Standards Dept. Copyright API. All rights reserved.

Refer to API 520, Part I for additional information related to the combination capacity factor when a rupture disk is installed in combination with a PRV.

9.2 Rupture Disks In Series

Occasionally, users may desire to install and use rupture disks in series. Depending upon the application, the disks may be installed in a rupture disk holder specifically designed for that arrangement. The “double disk assembly” is most commonly manufactured from three pieces; the inlet section of the rupture disk holder, the “mid-flange,” and the outlet portion of the device. They may be configured for either tension-loaded (forward-acting) or compression-loaded (reverse-buckling) rupture disks.

Rupture disks may also be used in series using two distinct and separate rupture disk holders separated by a spool piece.

It is critically important to remember that rupture disks are differential pressure devices and, accordingly, the space between the rupture disks shall have a free vent, pressure gauge, trycock, or other suitable telltale indicator to ensure no captive pressure in the intervening space is allowed to elevate the burst pressure of the primary (upstream) disk. A non-vented space with a pressure gauge without alarms or other indication devices is not recommended as a suitable telltale indicator, unless there are administrative controls to ensure that there is no accumulation of pressure between the two disks. This requirement is identical to that of the cavity between a pressure-relief valve and the rupture disk isolating the valve from the process environment.

The most common application for “double disk assemblies” is in highly hazardous chemical applications where any erosion or corrosion paths in the primary (upstream) disk is contained by the downstream disk preventing noxious, toxic, carcinogenic, or other hazardous product releases. ~~Should the primary (upstream) disk be required to activate~~ If the primary (upstream) disk activates—for the purpose of preventing an unsafe overpressure event, both disks will activate, simultaneously protecting the system. In this case, the disks are typically set at the same nominal burst pressure.

Another common use of double disk arrangements is to isolate the upstream disk from variable downstream pressure that would otherwise change the burst pressure of the first disk. In these applications, it is not uncommon for the burst pressure of the downstream disk to be lowered in order to account for the variable downstream pressure.

10 Bonnet or Pilot Vent Piping

10.1 General

The following sections discuss proper venting of bonnets and pilots depending on the type of PRV to ensure for proper operation of the valve. ~~Depending on the type of PRV, proper venting of the bonnets and pilots is required to ensure proper operation of the valve.~~

10.2 Conventional Valves

Bonnets on conventional PRVs can either be opened or closed type bonnets and do not have any special venting requirements. Open bonnets are often used in steam service and are directly exposed to the atmosphere. Valves with closed bonnets are internally vented to the PRV discharge. The bonnet normally has a tapped vent that is closed off with a threaded plug.

10.3 Balanced Bellows Valves

10.3.1 General

Balanced bellows PRVs minimize the effect of backpressure on the set pressure and relieving capacity of the valve by reducing the effect of backpressure on the force balance around the disk (see API 520, Part I,

This document is not an API Standard; it is under consideration within an API technical committee but has not received all approvals required to become an API Standard. It shall not be reproduced or circulated or quoted, in whole or in part, outside of API committee activities except with the approval of the Chairman of the committee having jurisdiction and staff of the API Standards Dept. Copyright API. All rights reserved.

Figure 8 and Figure 9). This requires that the bonnet operate at atmospheric pressure at all times.

BALLOT DRAFT

The bonnets of balanced bellows PRVs shall be vented to ensure proper functioning of the valve. The vent shall be designed to avoid plugging caused by insects, freezing, or other obstructions. Freezing may result from cold weather, cold service, or auto-refrigeration. Mitigation of freezing may include the use of heat tracing and insulation.

A failure of the bellows often results in leakage of fluid from the downstream side of the PRV into the bonnet and out the bonnet vent. When the fluid in the process or in the discharge system is flammable, toxic, or otherwise potentially harmful, e.g. corrosive, there may be risks caused by leakage from a failed bellows. If these risks cannot be reduced to a level acceptable to the user, then another type of relief valve should be selected. In reviewing the risks the user typically considers the conditions present at the bellows both during normal conditions as well as during relief. Relief conditions are typically more severe (due to higher pressure and process fluid properties) but may only be present for a short duration. ~~When the fluid in the process or in the discharge system is flammable, toxic, or otherwise potentially harmful, e.g. corrosive, the user should consider the risks caused by leakage from a failed bellows. If these risks cannot be reduced to a level acceptable to the user, another type of relief valve should be selected. In reviewing the risks, the user should consider the conditions present at the bellows both during normal conditions and during relief. Although the conditions during relief are typically more severe (higher pressure and process fluid properties), they should be present for only a short duration.~~ The more prolonged conditions are those when the relief valve is closed, and the bellows sees the conditions normally present in the discharge header. Additionally, the vent should be regularly checked for evidence of bellows leakage since this can significantly reduce the potential duration of any leakage.

The risks of leakage from the bonnet vent can often be mitigated by routing the vent to a safe location that is free of backpressure. Dispersion analysis or other appropriate methods may be used to determine a safe location. Figure 19, Figure 20, Figure 21, and Figure 22 show some bellows vent arrangements that may be used in various applications.

Bellows vent conduits may be constructed of pipe or tubing.

10.3.2 Bonnet Vent for Bellows Valve Handling Non-hazardous Vapors

In non-hazardous vapor service, an elbow and bug screen, as shown in Figure 19, should be installed on the bonnet vent opening to prevent insects from entering the bonnet. This also reduces the likelihood of mistakenly installing a plug in the open bonnet vent hole.

This document is not an API Standard; it is under consideration within an API technical committee but has not received all approvals required to become an API Standard. It shall not be reproduced or circulated or quoted, in whole or in part, outside of API committee activities except with the approval of the Chairman of the committee having jurisdiction and staff of the API Standards Dept. Copyright API. All rights reserved.

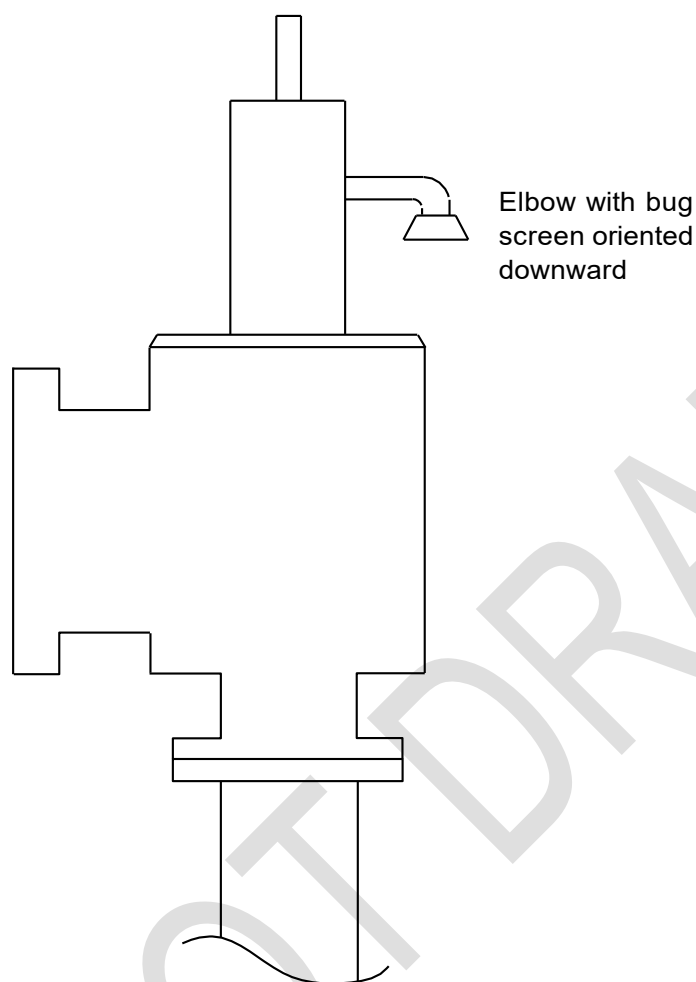
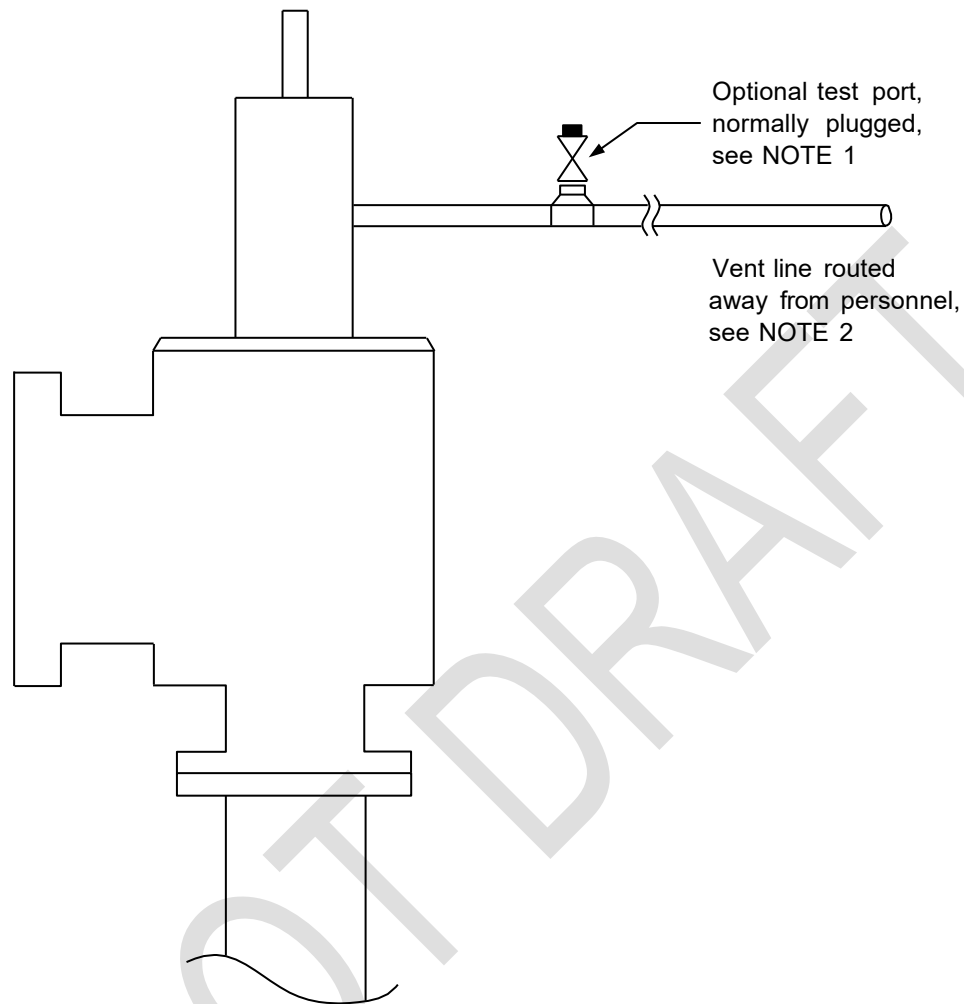

Figure 19—Bonnet Vent for Bellows Valves with Vent Located at the PRV

10.3.3 Bonnet Vent for Bellows Valve Handling Hazardous Vapors

The bonnet vent shall be vented to a safe location when the fluid in the process or discharge system contains hazardous vapors, ~~the bonnet vent may need to be routed to a safe location~~. Dispersion analysis or other appropriate methods may be used to determine ~~if a remote vent location is required~~ the safe location. Figure 20 shows an example of a bonnet vent design for bellows valves handling vapor with remote vent location. When a remote vent location is required, the vent line should be arranged to prevent ingress of rainwater and should be free draining, away from the bonnet, and have no pocketed section. The end of the vent line should be equipped with a bug screen.

This document is not an API Standard; it is under consideration within an API technical committee but has not received all approvals required to become an API Standard. It shall not be reproduced or circulated or quoted, in whole or in part, outside of API committee activities except with the approval of the Chairman of the committee having jurisdiction and staff of the API Standards Dept. Copyright API. All rights reserved.



NOTE 1 A test port may be provided to check for bellows leakage or plugged vent line.

NOTE 2 See 10.3.3.

Figure 20—Bonnet Vent for Bellows Valves Handling Vapor with Remote Vent Location

10.3.4 Bonnet Vent for Bellows Valve Handling Non-hazardous Liquids

The risks from non-hazardous liquids can be managed by routing the bonnet vent to a safe location at grade, as shown in Figure 21. Another option is to utilize an elbow with a bug screen, as illustrated in Figure 19. When considering this option, the user should evaluate the risks associated with spraying liquids out of the vent.

This document is not an API Standard; it is under consideration within an API technical committee but has not received all approvals required to become an API Standard. It shall not be reproduced or circulated or quoted, in whole or in part, outside of API committee activities except with the approval of the Chairman of the committee having jurisdiction and staff of the API Standards Dept. Copyright API. All rights reserved.

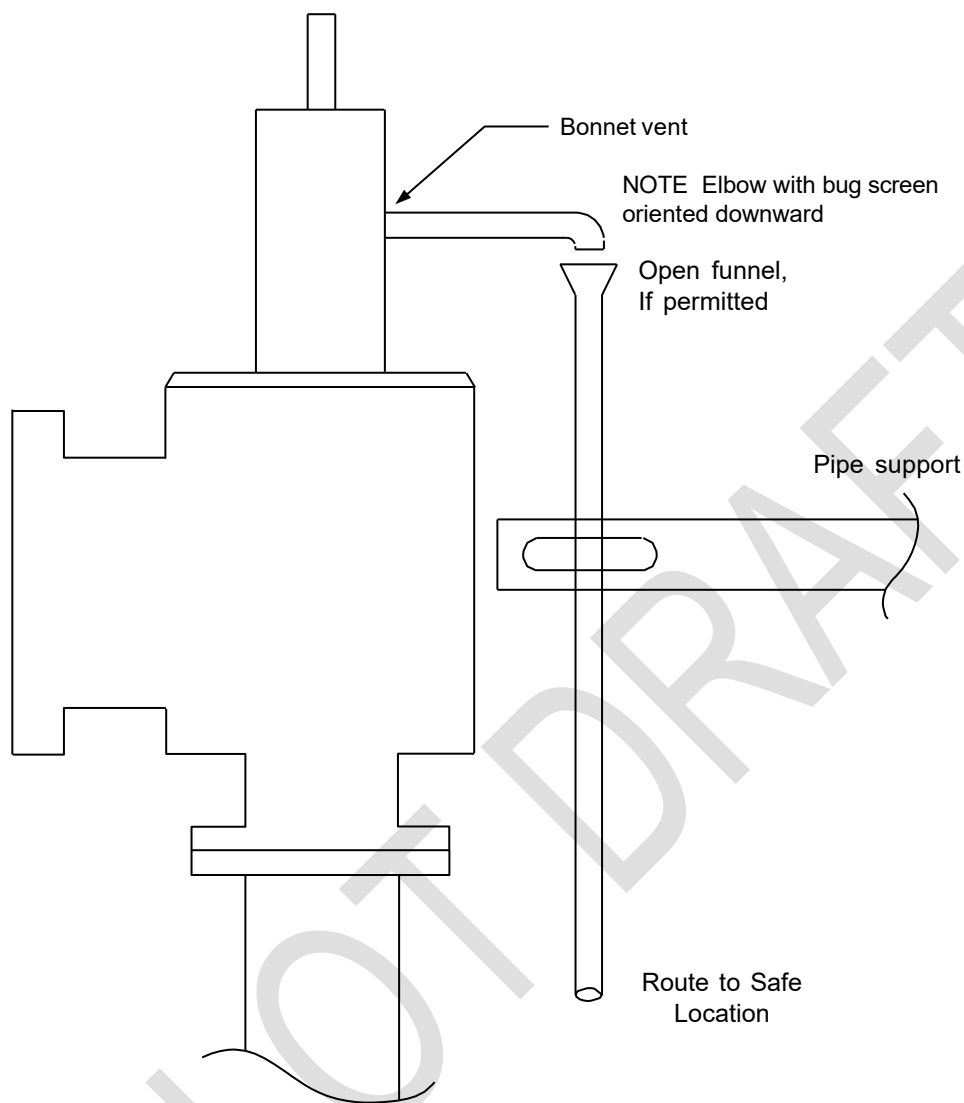

Figure 21— Bonnet Vent for Bellows Valves Handling **Non-Hazardous** Liquids Where ~~a Leak Needs to~~ the Vent is Be Routed Away from the PRV

10.3.5 Bonnet Vent for Bellows Valve Handling Hazardous Liquids

Due to the variability of processes, general guidelines for routing vent lines for hazardous liquids cannot be given. It is the responsibility of the user to design the vent line for these applications.

One option to consider is as shown in Figure 22. If the liquid release is expected to flash off any vapor, a separation pot and vent stack as shown in Option 2 of Figure 22 is recommended.

If the fluid in the process or discharge system is an acutely toxic liquid, the user should evaluate the risks associated with bellows leak to determine if the bellows vent can be safely routed to the atmosphere. ~~a hazard analysis should be performed to determine if the bellows vent can be safely routed to the atmosphere.~~ A balanced bellows valve might not be an acceptable design option due to the potential difficulties with routing these liquids to a safe location.

This document is not an API Standard; it is under consideration within an API technical committee but has not received all approvals required to become an API Standard. It shall not be reproduced or circulated or quoted, in whole or in part, outside of API committee activities except with the approval of the Chairman of the committee having jurisdiction and staff of the API Standards Dept. Copyright API. All rights reserved.

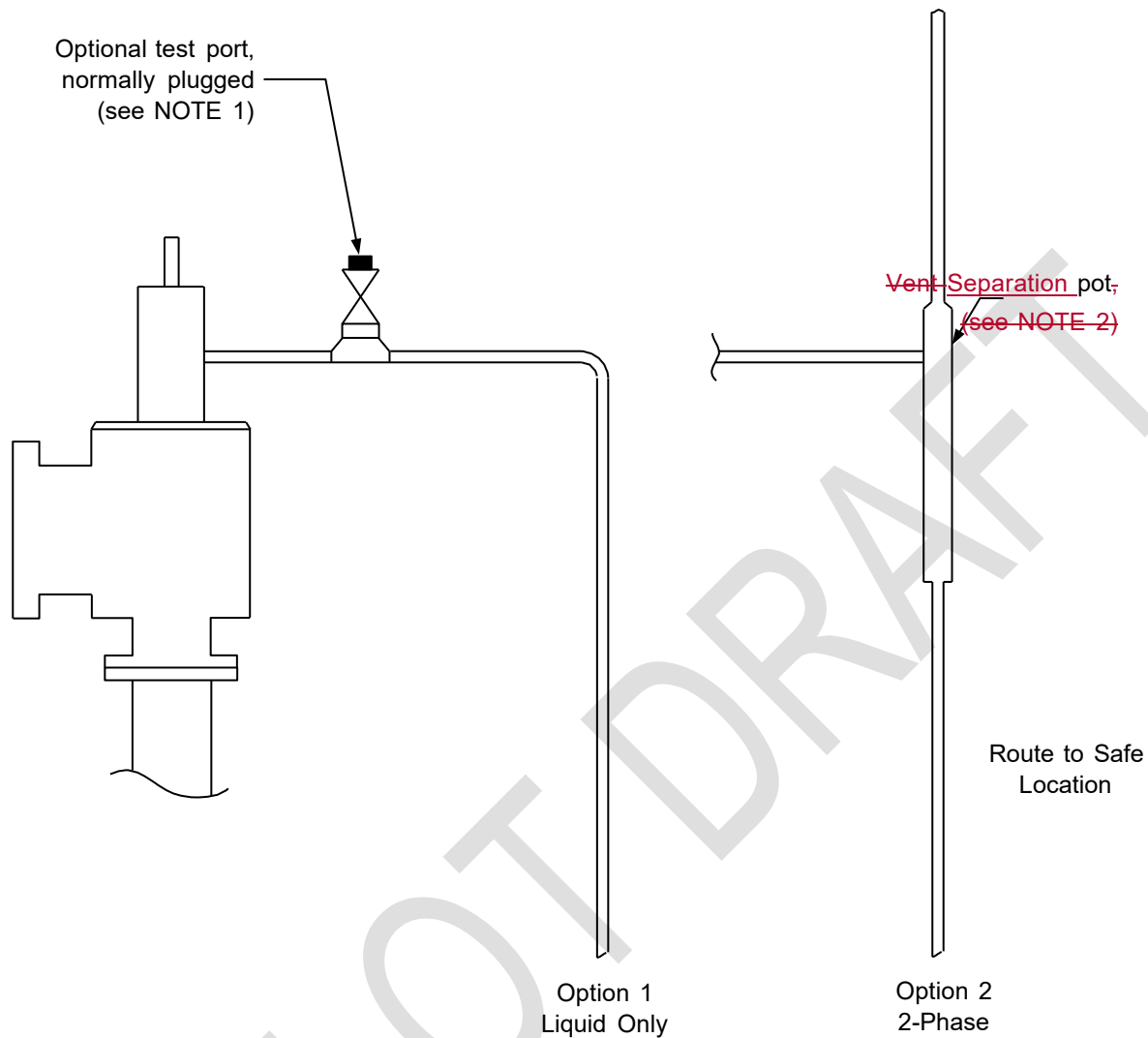

NOTE 1 A test port may be provided to check for bellows leakage or a plugged vent line.

NOTE 2 For flashing liquid and vapor, the pot must be large enough to disengage the liquid.

Figure 22—Bonnet Vent for Bellows Valves Handling Liquids or Flashing Liquid and Vapor with Remote Vent Location

10.4 Balanced Piston Valves

Balanced piston PRVs are utilized in applications to minimize the effect of backpressure, similar to the balanced bellows valve. Proper operation depends on cancellation of the backpressure effect on opposing faces of the valve disk and balance piston. Since the piston area is equal to the nozzle seat area, the pressure in the ~~spring~~ bonnet should be atmospheric pressure.

A failure of the piston seal will allow leakage of fluid from the downstream side of the PRV into the bonnet and out the bonnet vent. Because of the potential for flow of system media past the piston, the bonnets of balanced piston valves should always be vented to atmosphere at a safe location (see 10.3).

10.5 Pilot-Operated Valves

The pilot vent shall be vented to a safe location. Since the discharge during operation is small, pilot discharge

This document is not an API Standard; it is under consideration within an API technical committee but has not received all approvals required to become an API Standard. It shall not be reproduced or circulated or quoted, in whole or in part, outside of API committee activities except with the approval of the Chairman of the committee having jurisdiction and staff of the API Standards Dept. Copyright API. All rights reserved.

is often vented to atmosphere. When a remote vent discharge is used, the pilot should be vented either to the discharge nozzle or through a supplementary piping system to a safe location. When vent piping is designed, avoid excessive backpressure on the pilot vent (as determined by the valve manufacturer).~~The pilot discharge is often vented to the atmosphere under operating conditions, since the discharge during operation is small. When vent discharge to the atmosphere is not permissible, the pilot should be vented~~

BALLOT DRAFT

This document is not an API Standard; it is under consideration within an API technical committee but has not received all approvals required to become an API Standard. It shall not be reproduced or circulated or quoted, in whole or in part, outside of API committee activities except with the approval of the Chairman of the committee having jurisdiction and staff of the API Standards Dept. Copyright API. All rights reserved.

~~either to the discharge piping or through a supplementary piping system to a safe location. When vent piping is designed, avoid the possibility of backpressure on the pilot unless the pilot is a balanced design.~~

If the pilot valve is a balanced type of valve, the bonnet vent on the pilot should be vented in accordance with 10.3.

11 Drain Piping

11.1 Installation Conditions that Require Drain Piping

Discharge piping from PRDs shall be ~~drained properly designed~~ to prevent the accumulation of liquids on the downstream side of the PRD. The outlet piping to closed systems should be self-draining to a liquid disposal point, thereby eliminating the need for a physical drain or drain piping from the discharge piping or the PRV.

When the discharge piping is not self-draining and the device is located where liquids could accumulate at the outlet, drain piping should be provided. This drain piping could be installed on the discharge piping or installed at the PRV in the body connection provided for this purpose.

Since conventional relief valves and rupture disks are differential pressure devices, accumulation on the downstream side of the device can affect the pressure at which the device will activate. In addition, the accumulation of liquid downstream for all relief devices can result in deficiencies in the discharge system, such as corrosion, plugging, and slug flow. Applications where the relief device vents directly to atmosphere should have an adequately sized weep hole or some other means to prevent the accumulation of rainwater in the vent pipe.

11.2 Safe Practice for Installation of Drain Piping

Design, operation, and maintenance of drain piping that is part of the discharge system warrant the same level of care that is applied to the rest of the system. The drain piping installation shall not adversely affect the relief device performance. Flammable, toxic, or corrosive fluids shall be routed to a safe location. Procedures or controls shall be ~~sufficiently robust in place~~ to prevent accumulation of liquids that could prevent the relief device from operating properly. Drain piping may require purging or heat tracing to maintain its functionality.

12 Pre-installation Handling and Inspection

12.1 General

In addition to the recommendations provided in this section, excellent guidance on the proper handling and inspection of PRDs can be found in API 576^[4].

12.2 Storage and Handling of PRDs

Because cleanliness is essential to the satisfactory operation and tightness of a PRV, precautions should be taken during storage to keep out all foreign materials. Valves should be closed off properly at both inlet and outlet flanges. Take particular care to keep the valve inlet absolutely clean. PRVs should be, when possible, stored indoors on pallets away from dirt and other forms of contamination.

PRDs should be handled carefully and should not be subjected to shocks, which can result in considerable internal damage or misalignment. For valves, seat tightness may be adversely affected.

Rupture disks should be stored in the original shipping container.

This document is not an API Standard; it is under consideration within an API technical committee but has not received all approvals required to become an API Standard. It shall not be reproduced or circulated or quoted, in whole or in part, outside of API committee activities except with the approval of the Chairman of the committee having jurisdiction and staff of the API Standards Dept. Copyright API. All rights reserved.

12.3 Inspection and Cleaning of Systems Before Installation

Because foreign materials that pass into and through PRVs can damage the valve, the systems on which the valves are tested and finally installed shall also be inspected and cleaned. New systems in particular are prone to contain welding beads, pipe scale, and other foreign objects that inadvertently get trapped during construction and will damage the seating surface when the valve opens. The system ~~should~~shall be ~~thoroughly~~ cleaned before the PRV is installed.

PRDs should be removed or isolated before hydrotesting or pneumatic pressure testing of the system, either by blanking or closing an isolation valve. If an isolation valve is used, the flanges between the isolation valve and the PRD should be wedged open or a bleed valve provided so that inadvertent leaking through the isolation valve does not lift the PRD.

13 Pressure-relief Device Installation and Maintenance

13.1 Mounting Position

PRVs and rupture pin valves should be mounted in a vertical upright position. Installation of a PRV in other than a vertical upright position may adversely affect its operation. The valve manufacturer should be consulted about any other mounting position, since mounting a PRV in other positions may cause a shift in the set pressure and a reduction in the degree of seat tightness.

Additionally, another position may permit liquids to collect in the spring bonnet. Solidification of these liquids around the spring may interfere with the valve operation.

Rupture disk devices may be installed vertically or horizontally. Inlet and discharge piping shall be adequately supported and aligned to prevent excessive loads due to the weight of piping components or applied moments.

13.2 Care in Installation

Before a PRD is installed, the flanges on the PRV or rupture disk holder and the mounting nozzle should be free of any foreign material that may cause leakage. Flange faces should be inspected for damage. Where PRDs are too heavy to be readily lifted by hand, the use of proper handling devices will avoid damage to the flange gasket facing. Ring joint and tongue-and-groove joint facings should be handled with extreme care so that the mating sections are not damaged.

13.3 PRVs

The condition of all PRVs should be visually inspected before installation. Consult the manufacturer's instruction manuals for details relating to the specific valve. Ensure that all protective material on the valve flanges and any extraneous materials inside the valve body and nozzle are completely removed. Bonnet shipping plugs shall be removed from balanced PRVs. The inlet surface shall be cleaned, since foreign materials clinging to the inside of the nozzle will be blown across the seats when the valve is operated. Some of these materials may damage the seats or get trapped between the seats in such a way that they cause leakage. Valves should be tested before installation to confirm their set pressure.

For valves that have been in service, the user shall conduct a review of the valve's inspection/maintenance records and obtain experience from Operations to identify any indications of chatter. Any evidence of chatter ~~should~~shall trigger a review of the PRV system's design.

13.4 Rupture Disk Devices

All rupture disk devices should be ~~thoroughly~~ inspected before installation, according to the manufacturer's instruction manuals. The seating surfaces of the rupture disk holder shall be clean, smooth, and undamaged.

This document is not an API Standard; it is under consideration within an API technical committee but has not received all approvals required to become an API Standard. It shall not be reproduced or circulated or quoted, in whole or in part, outside of API committee activities except with the approval of the Chairman of the committee having jurisdiction and staff of the API Standards Dept. Copyright API. All rights reserved.

Rupture disks should be checked for physical damage to the seating surfaces or the pre-bulged disk area. Damaged or dented disks should not be used. Apply the proper installation and ~~torqueing~~ torquing procedure as recommended by the rupture disk device manufacturer.

On reverse-buckling disks that have knife-blade assemblies, the knife blades shall be checked for physical damage and sharpness. Nicked or dull blades shall not be used. Damaged rupture disk holders shall be replaced (see Annex A).

13.5 Pin-actuated Devices

Buckling pin-actuated devices should be installed and maintained in accordance with the manufacturer's requirements. Annex B provides guidance on the installation and maintenance of pin-actuated devices.

13.6 Proper Gasketing and Bolting for Service Requirements

~~The gaskets used shall be dimensionally correct for the specific flanges; they should fully clear the PRD inlet and outlet openings.~~ The gaskets used shall be dimensionally correct for the specific flanges fully clear of the PRD inlet and outlet openings.

Gaskets, flange facings, and bolting should meet the service requirements for the pressure and temperature involved. This information can be obtained by referring to other national standards and to manufacturers' technical catalogs.

When a rupture disk device is installed in the pressure-relief system, the flange gasket material and bolting procedures may be critical. The disk manufacturer's instructions should be followed for proper performance (see Annex A).

13.7 Inspection and Maintenance

~~For optimum performance,~~ PRDs shall be serviced and maintained regularly in accordance with API 570. Details for the care and servicing of specific PRDs are provided in the manufacturer's maintenance bulletins and in API 576^[4]. Any evidence of damage due to chatter ~~should~~ shall trigger a review of the PRV system's design.

PRDs should be located for easy access, removal, and replacement so that servicing can be properly performed. Sufficient working space should be provided around the PRD.

13.8 ~~Test or~~ Lifting Levers

~~Test or~~ Lifting levers ~~should~~ shall be provided on PRVs as required by the applicable code. Where levers are provided, they should hang downward, and the lifting fork should not contact the lifting nuts on the valve spindle. Uploads caused by the lifting-mechanism bearing on the spindle will cause the valve to open below the set pressure. The lifting mechanism should be checked to ensure that it does not bind on the valve spindle.

Where ~~it is necessary to have~~ the test-lift lever ~~in-is in a position~~ other than a vertical ~~position~~, or where the test-lift lever is arranged for remote manual operation, the lever should be counterbalanced so that the lifting mechanism, unless actuated, does not exert any force on the valve spindle lifting nut.

In lieu of lifting levers for pilot-operated PRVs, means may be specified for connecting and applying adequate pressure to the pilot to verify that the moving parts critical to proper operation are free to move.

13.9 Heat Tracing and Insulation

For materials that are highly viscous, materials that could result in corrosion upon cooling, or materials that could potentially solidify in PRDs, adequate heat tracing or insulation shall be provided for both inlet and outlet piping to PRDs, as well as remote sensing lines for pilot-operated PRVs. Ensure that any discharge or vent port are not covered when the valve is insulated.

PRD heat tracing shall be appropriate for the materials of construction, service conditions and relief device design. ~~For materials that are highly viscous, materials that could result in corrosion upon cooling, or materials that~~

This document is not an API Standard; it is under consideration within an API technical committee but has not received all approvals required to become an API Standard. It shall not be reproduced or circulated or quoted, in whole or in part, outside of API committee activities except with the approval of the Chairman of the committee having jurisdiction and staff of the API Standards Dept. Copyright API. All rights reserved.

~~could potentially solidify in PRDs, adequate heat tracing or insulation should be provided for the PRDs themselves (including pilots), including both the inlet and outlet piping to PRDs, as well as remote sensing and exhaust lines for pilot-operated PRVs. Ensure that any discharge or vent ports are not covered when the valve is insulated.~~

~~PRD heat tracing should be appropriate for the materials of construction, service conditions, and relief device design. The reliability of the tracing system shall be maintained in order to ensure proper operation of the PRD.~~

BALLOT DRAFT

This document is not an API Standard; it is under consideration within an API technical committee but has not received all approvals required to become an API Standard. It shall not be reproduced or circulated or quoted, in whole or in part, outside of API committee activities except with the approval of the Chairman of the committee having jurisdiction and staff of the API Standards Dept. Copyright API. All rights reserved.

Annex A (informative)

Rupture Disk Installation Guidelines

A.1 General

This annex provides basic guidelines for the correct installation of rupture disks in a typical piping/pressure-relief scheme. Correct installation of rupture disks will both ensure accurate burst pressures and afford the longest possible service life of the rupture disk. Due to the variety of styles and types of rupture disks commercially available, it is impractical to discuss them all in this annex. Accordingly, this annex will only discuss typical industrial applications using more common rupture disks and rupture disk holders. Installation considerations for more specialized rupture disk products (sanitary/aseptic rupture disks, disks for high viscosity fluid environments, plastic extruder products, etc.) should be acquired from rupture disk manufacturers. Should any information presented be in conflict with the specific installation instructions of any rupture disk manufacturer, the manufacturer's installation instructions should take priority. Personnel involved in the installation and maintenance of rupture disks should be properly trained. When removing a rupture disk device from a pressure-relief scheme, the user is reminded that the device may be contaminated with toxic or hazardous process media. Appropriate care should be taken to prevent injuries.

A.2 Companion Flanges

The pipe flanges, into which a rupture disk is to be installed, are herein called the "companion flanges." The companion flanges should be properly spaced and aligned to ensure the piping scheme does not apply its own unknown and unwanted piping stress or clamping forces to the device that may impact the performance of the rupture disk. Figure A.1 provides a typical configuration of companion flanges, gaskets, and rupture disk assembly.

A.3 Gasket Selection

Although there are exceptions, rarely are gaskets used between the rupture disk and the rupture disk holder, the typical seal being affected metal-to-metal. The companion flange gaskets used for installing the rupture disk device in a piping scheme shall be selected for process compatibility; they should also be selected so the force required to properly energize the gasket does not significantly exceed the companion flange bolt torque specified by the rupture disk manufacturer's installation instructions. Depending upon the type of disk in use, exceeding the manufacturer's specified torque may dramatically change the burst pressure, crush the disk materials of construction, cause leakage, result in premature activation, and/or damage the rupture disk holder so proper performance of subsequent installations is impossible without replacing the holder. If the gasket of choice is "spiral wound," gaskets selected should be the "low stress" or "low energy" type to minimize the probability of burst pressure changes and holder damage. Most rupture disk manufacturers encourage the use of high-quality, non-asbestos, compressed fiber gaskets. However, other gaskets, such as fiber-filled and non-cold flowing fluoropolymer gaskets, are also suitable. Clearly, the intent is to ensure a positive system seal without overloading the rupture disk device. Typically, used gaskets should be replaced whenever the disk device is disassembled during field service.

This document is not an API Standard; it is under consideration within an API technical committee but has not received all approvals required to become an API Standard. It shall not be reproduced or circulated or quoted, in whole or in part, outside of API committee activities except with the approval of the Chairman of the committee having jurisdiction and staff of the API Standards Dept. Copyright API. All rights reserved.

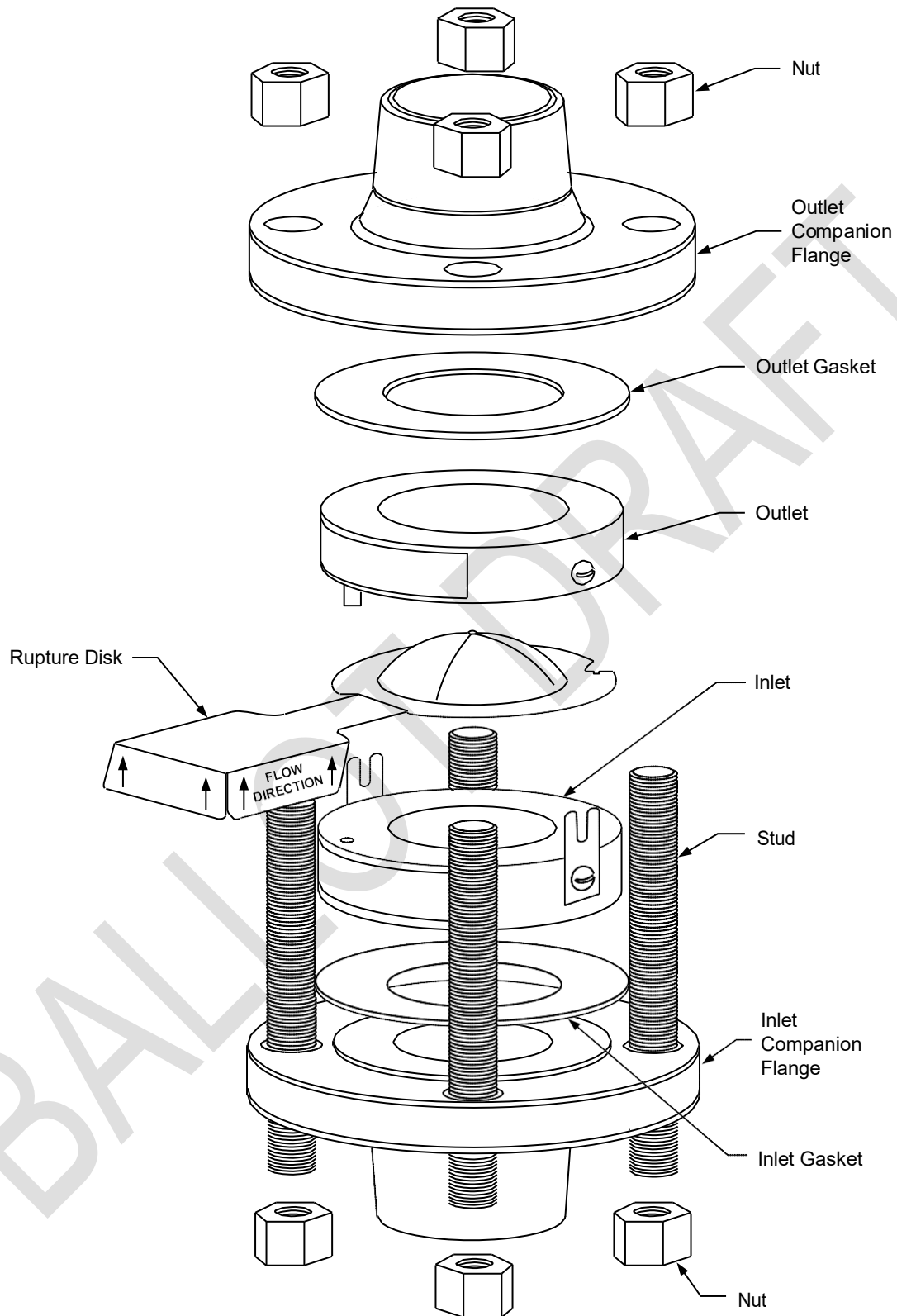

Figure A.1—Typical Configuration of Companion Flanges, Gaskets, and Rupture Disk Assembly

This document is not an API Standard; it is under consideration within an API technical committee but has not received all approvals required to become an API Standard. It shall not be reproduced or circulated or quoted, in whole or in part, outside of API committee activities except with the approval of the Chairman of the committee having jurisdiction and staff of the API Standards Dept. Copyright API. All rights reserved.

A.4 Rupture Disk Holder Serviceability

Ensure the condition of the rupture disk holder is clean, free from debris, and not coated, plated, or plugged by process materials. Ensure clean gasket surfaces on the outside of the holder. Since the “disk/holder interface” ensures proper rupture disk performance, holders should be cleaned with appropriate solvents and very fine emery cloth to ensure the critical seating surface dimensions are not changed. Bead blasters (or equivalent) should never be used to clean a rupture disk holder. No modifications should be made to a rupture disk holder, except by its original manufacturer. Most manufacturers will evaluate holders for serviceability and, in some cases, can re-machine critical dimensions and return a holder to the user for continued service if it has been damaged through improper installation, excessively aggressive cleaning, and/or superficial corrosion. If the rupture disk device is of a type activated by knife blades installed in and integral to the outlet of the rupture disk holder, caution is directed to ensure the blades are maintained in strict compliance with the manufacturer’s guidance.

A.5 Rupture Disk Suitability for Application

Confirm that the disk to be installed is the disk specified for the application and that the disk is compatible with the selected rupture disk holder. Not uncommonly, plants have a wide variety of styles of rupture disks and associated rupture disk holders. Compatibility is crucial. A rupture disk installed in a holder not designed for that style of disk can create a hazardous situation. Verify with the manufacturer’s installation instructions (or by contacting the manufacturer) that the disk intended for installation is compatible with the holder to be used.

A.6 Preparing the Rupture Disk for Installation

A rupture disk should not be removed from the manufacturer’s packaging until ready to be installed in the holder. Rupture disks should be handled carefully and only by the external rim of the disk and the rupture disk tag, as illustrated in Figure A.2. The surface of the pressure-sensitive element of the disk (commonly the “dome” or “crown”) should not be touched (see Figure A.3).

When the holder has been prepared to receive the new disk, the disk should be removed from the packaging. Prior to installation of the disk into the holder, the rupture disk should be very carefully inspected for damage. Any damage to the disk will affect the burst pressure and may create an unsafe installation and/or cause significantly reduced service life. A damaged disk should never be installed. Performance-influencing damage is usually quite visible. If any surface anomaly is visible from both sides of the disk, it should not be installed, regardless of how slight the damage may be. Depending upon the type or style of disk used, even a tiny amount of damage may result in an unsafe installation.

Personnel responsible for inspection and installation of rupture disks should be properly trained to avoid rejecting serviceable disks. For example, disks are occasionally heat treated and show, as a result, a discoloration that is not a criterion for rejection. Disks sometimes also show on their surface mill marks that typically appear to be fine parallel scratches on the surface of the disk. The presence of mill marks is not a sufficient reason to reject the disk. Always consult with the manufacturer if unsure whether a disk is damaged and unsafe to install.

A.7 Installation of the Rupture Disk into the Rupture Disk Holder

When installing a rupture disk into the holder, there should be no more than one disk in the vicinity of the holder to eliminate the risk of the wrong disk being installed. With the inlet and outlet of the holder being separated, the disk should be carefully installed on the top of the inlet. The disk should be of the form, fit, and function to align itself properly on the inlet half of the holder. In some cases, special centering and locating features are supplied by the manufacturer. Commonly, special notches or offset locating pins ensure proper alignment, centering, and directional orientation. On other types of disks and holders, the centering and alignment are characteristic of the compatible shape of the rim of the disk and its holder interface, such as an “angular” seating surface. Regardless of the particular design, the installation of the disk in the holder should

This document is not an API Standard; it is under consideration within an API technical committee but has not received all approvals required to become an API Standard. It shall not be reproduced or circulated or quoted, in whole or in part, outside of API committee activities except with the approval of the Chairman of the committee having jurisdiction and staff of the API Standards Dept. Copyright API. All rights reserved.

be straightforward, easy, and require no effort. If the fit is difficult, refer to the manufacturer's installation

BALLOT DRAFT

This document is not an API Standard; it is under consideration within an API technical committee but has not received all approvals required to become an API Standard. It shall not be reproduced or circulated or quoted, in whole or in part, outside of API committee activities except with the approval of the Chairman of the committee having jurisdiction and staff of the API Standards Dept. Copyright API. All rights reserved.

instructions or contact the manufacturer. With the disk properly seated on the inlet, the outlet of the holder may be installed on top of the disk. Extreme care shall be exercised to prevent damage to the disk while installing the outlet portion of the holder. The outlet should, likewise, easily align and center on the vent (downstream; atmospheric) side of the disk. Once the disk is installed between the inlet and outlet of the holder, a variety of mechanisms are provided by manufacturers to hold the rupture disk device together, prior to being installed in the piping scheme. Commonly, there are “side lugs” used for this purpose. In other designs, the assembly is properly torqued together with recessed cap screws. As always, follow the manufacturer’s installation instructions to properly retain the integrity of the rupture disk device and prevent damage to the disk; pay particular attention to directional orientation.

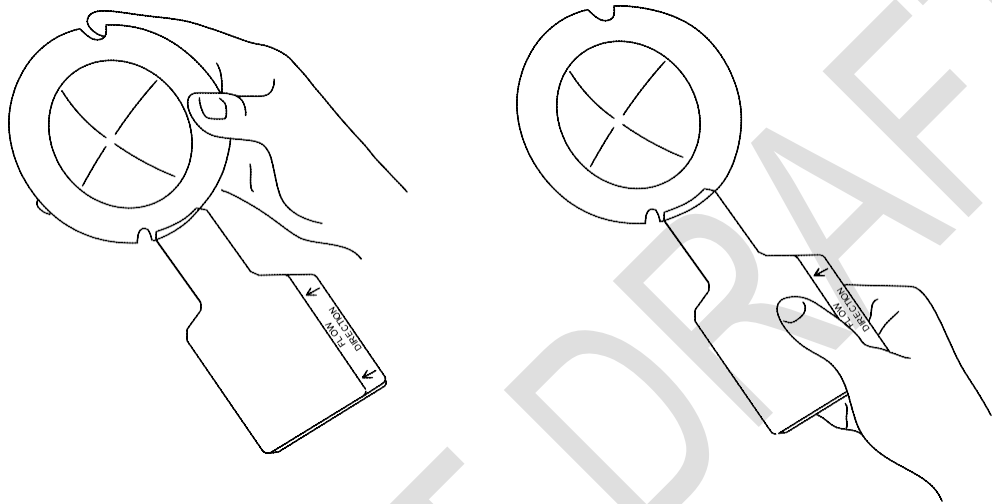

Figure A.2—Proper Handling of a Rupture Disk



This document is not an API Standard; it is under consideration within an API technical committee but has not received all approvals required to become an API Standard. It shall not be reproduced or circulated or quoted, in whole or in part, outside of API committee activities except with the approval of the Chairman of the committee having jurisdiction and staff of the API Standards Dept. Copyright API. All rights reserved.

Figure A.3—Improper Handling of a Rupture Disk

BALLOT DRAFT

This document is not an API Standard; it is under consideration within an API technical committee but has not received all approvals required to become an API Standard. It shall not be reproduced or circulated or quoted, in whole or in part, outside of API committee activities except with the approval of the Chairman of the committee having jurisdiction and staff of the API Standards Dept. Copyright API. All rights reserved.

A.8 Installation of the Rupture Disk Device Into a Piping/Pressure-relief System

Ensure the gasket surfaces of the companion flanges are clean and prepared for new gaskets. Once again, paying critical attention to proper direction orientation (see flow arrows on the disk and holder and installation instructions for installation direction as shown in Figure A.4), install the assembled rupture disk device and gaskets between the companion flanges and install the companion flange studs.

The rupture disk holder should be of the proper flange rating to effectively self-center between the studs. Proper performance of the rupture disk and longest service life is significantly improved by following the manufacturer's torque requirements for the companion flange studs. Progressively tightening the studs in increasing one-fourth increments of the required torque load helps to equally distribute clamping force on the rupture disk holder, ensuring proper sealing and disk performance. Typically, the torque to the studs should be applied following a "cross-torquing" pattern. Always ensure the installation instructions are followed to ensure that proper torque is applied.

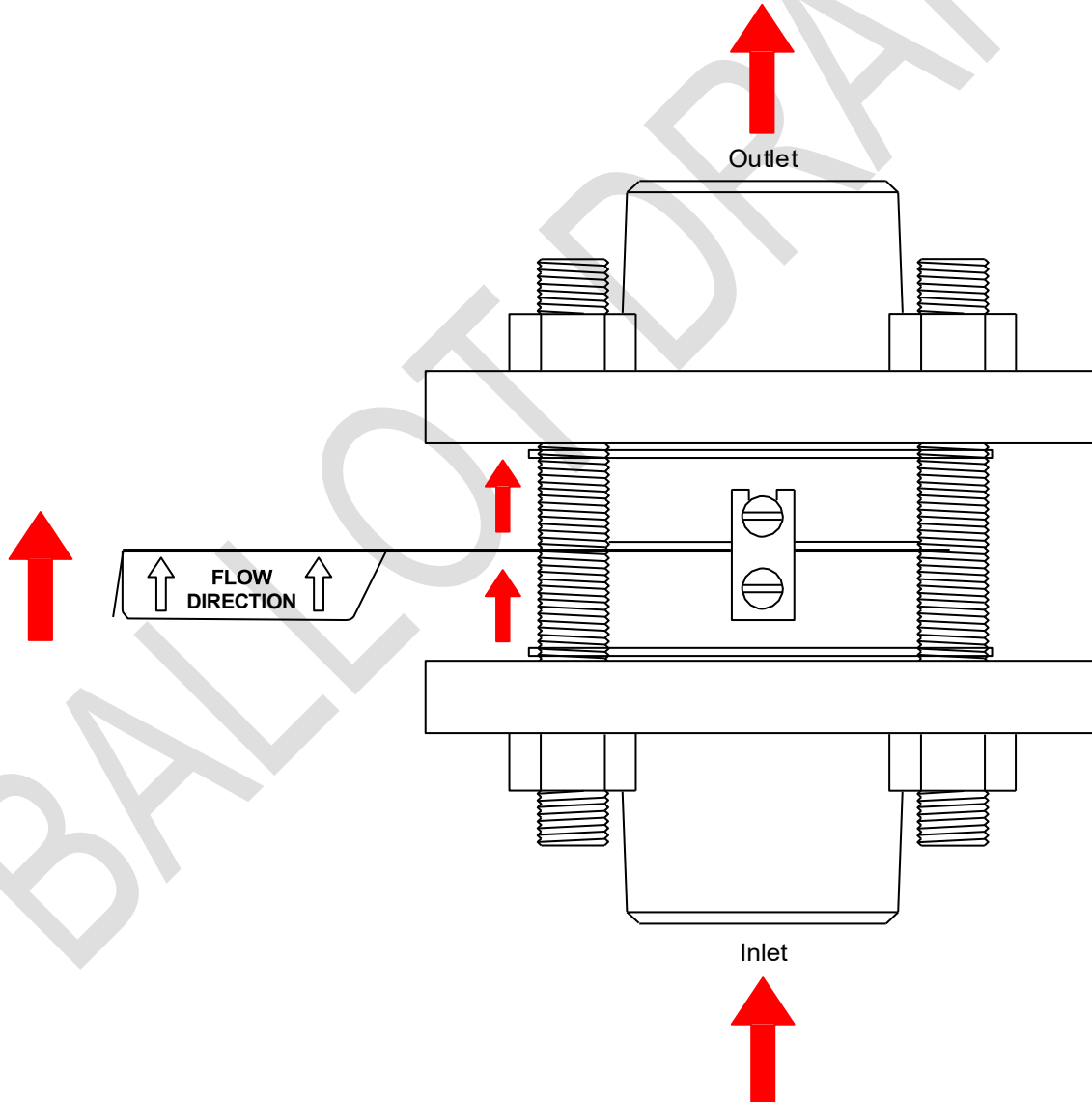

Figure A.4—Proper Alignment of Rupture Disk Indicated by Tag Arrows

This document is not an API Standard; it is under consideration within an API technical committee but has not received all approvals required to become an API Standard. It shall not be reproduced or circulated or quoted, in whole or in part, outside of API committee activities except with the approval of the Chairman of the committee having jurisdiction and staff of the API Standards Dept. Copyright API. All rights reserved.

A.9 Rupture Disk Life-Cycle and Maintenance

Rupture disk manufacturers provide instructions and guidelines for the proper installation and maintenance of the variety of rupture disk designs they offer. However, since rupture disk performance is unique to each disk type and the specific application environment into which it is installed, the maintenance routine and frequency of replacement cannot be generalized. Certainly, some disks are better suited for some applications than others. Service life (durability) is a function of both the disk design and the particular application conditions. Is the disk specified designed to be fully process compatible with corrosive conditions? Is it designed to be highly resistant to cyclic fatigue? Is the disk design suited for the maximum operating pressures to which it will be exposed? These and other associated questions can only be answered by a discussion about the disk style or type with complete consideration of the application.

In general, rupture disk manufacturers discourage the re-use of a disk anytime the clamping force at the disk-holder interface is relaxed/relieved since the performance of a reinstalled disk is unpredictable. Once the torque (clamping force) on a disk is removed, the probability that a reinstalled disk taking the same "set" as during initial installation is remote. Depending on the design, the disk may not be suitable for re-use once disassembled, even if the parts have not been damaged in handling and disassembly. Always verify with the manufacturer if a particular disk assembly can be reinstalled. If a disk is installed in a pre-torqued holder, the rupture disk assembly may be removed from the piping scheme, carefully inspected, and returned to service if the disk isn't pitted from corrosion, heavily plated, or contaminated with process media, etc. If the disk appears in good condition, it may be re-used since the clamping force on the disk has not been disturbed in the pre-torqued rupture disk holder.

It is not uncommon for rupture disks to be damaged during handling and installation due to the reasonably fragile nature of rupture disks in general, and specifically those disks designed for low-pressure applications. Damaged disks should never be installed. Although damage suitable for disk rejection is, again, characteristic of a particular disk design, any damage evident on the dome or crown of a disk that is visible on both sides of the pressure-sensitive element (positive and negative dents or scratches) is justification for rejection since the precision and serviceability are probably compromised and will most likely result in premature or nuisance activations. Superficial "scratches" are commonly "mill marks" caused by the rolling of the disk material to different thicknesses. Mill marks are inconsequential and do not impact disk performance.

Depending upon the disk type and manufacturing procedures, disks may be annealed or thermally stress relieved. This process may result in the superficial discoloration of the disk material, which is rarely disqualifying. Should discoloration be undesirable for a particular application, the end user may request disks be vacuum annealed or heat treated in an inert environment such as argon.

If the user/installer sees any characteristic that is perceived as damage, the manufacturer should be contacted to verify serviceability or cause for rejection. Conveniently, digital photos of rupture disks may be sent to the manufacturer for responsive evaluation of suitability of service.

Often overlooked is the condition of the rupture disk holder. The holder should be maintained as recommended by the manufacturer. The disk/holder interface usually has critical dimensions that will change the performance and precision of the rupture disk device if compromised. Rupture disk holders should not be cleaned by bead or sand blaster. Process plating should be carefully removed from the rupture disk holder using fine emery cloth to maintain the correct tolerances. Rupture disk holders may also be damaged or permanently "deflected" by excessive torque supplied by the pipe flanges and studs. Rupture disk manufacturers provide a recommended pipe flange torque to ensure adequate system sealing while concurrently preserving the serviceability of the holder. Issues related to pipe flange stud torque beyond that recommended in installation instructions should be directed to the disk manufacturer.

A properly installed rupture disk will provide the intended safety and pressure relief at the pressure and temperature specified by the user. Additionally, a properly installed rupture disk device will ensure the longest service life and best performance, and minimize the possibility of nuisance and fatigue activations caused by inattentive and improper installation.

Annex B

(informative)

Installation and Maintenance of Pin-actuated Non-reclosing PRDs

B.1 General

Pin-actuated non-reclosing PRDs comprise two main components. The first component is the mechanism (piston or disk) that moves from the “closed” to the “open” position during the overpressure event. The second main component is the buckling pin that maintains the piston or disk in the closed position and that buckles in response to overpressure to activate the opening of the disk. To ensure the proper performance of such pin-actuated devices, the following installation and maintenance requirements should be followed.

B.2 Installation

The following provides guidance on the installation of pin-actuated non-reclosing PRDs.

- 1) Ensure that the main body/mechanism and the supplied buckling pin are provided by the same manufacturer. These items function together to provide the required pressure system protection. Verify that the pins are certified by the manufacturer for use in the mechanism.
- 2) Use only buckling pins that are traceable to the device manufacturer through appropriate documentation, such as a tag or other marking permanently attached to the pin. Do not install unmarked, and therefore, untraceable, buckling pins.
- 3) Ensure that the device is installed in the correct directional orientation. Follow the flow direction indicated on the device and verify using the manufacturer’s installation instructions.
- 4) Ensure that the device is installed in the directional orientation as originally specified to the manufacturer. Some buckling pin-actuated PRDs are “gravity balanced” since the weight of the opening mechanism contributes to the set pressure of the device. Again, follow specifically the manufacturer’s installation instructions and make certain that the device has been purchased to accommodate the installation configuration (horizontal/vertical/oblique flow).
- 5) Do not install buckling pins made for service in one device type into a different mechanism design. Buckling pins are calibrated to and certified for use in a single mechanism, as identified by the manufacturer.
- 6) Install only buckling pins that are straight. Pins that have any deformity or curvature will typically cause the associated PRD to function at a reduced set pressure.
- 7) Some buckling pin-actuated PRDs are operated by differential pressure. Ensure that such devices are installed with a downstream pressure that is either monitored to maintain an appropriate pressure differential, or held at atmospheric pressure.
- 8) Follow the manufacturer’s pin installation instructions and use special tools where recommended. Buckling pins are commonly installed into a mechanism housing. Ensure that any bolts or “fasteners” are not overtightened, since overtightening can lead to pin deflection and failure during installation.
- 9) Where electrical sensors are used with and fitted to the pin-actuated PRD, ensure that the appropriate electrical design standards for the application are met.
- 10) Ensure that the installation is capable of containing/resisting recoil forces from the activation of the buckling pin-actuated PRD.

This document is not an API Standard; it is under consideration within an API technical committee but has not received all approvals required to become an API Standard. It shall not be reproduced or circulated or quoted, in whole or in part, outside of API committee activities except with the approval of the Chairman of the committee having jurisdiction and staff of the API Standards Dept. Copyright API. All rights reserved.

- 11) Pins shall neither be removed nor installed while the device is exposed to pressure. Attempting to do so can lead to premature activation of the PRD and/or injury to the user/operator.
- 12) If the device is supplied with a fluid drain to prevent accumulation of products within the device, ensure that the drain is safely discharged to a safe and appropriate location.

B.3 Maintenance

The following provides guidance on the maintenance of pin-actuated non-reclosing PRDs.

- 1) Buckling pin-actuated PRDs can be reset as a maintenance activity without complete removal of the device from the pressure-relief system. Prior to reset, ensure that the system is not pressurized. Device reset requires the installation of a replacement buckling pin. Follow the manufacturer's instructions for removal of the used pin, reclosing of the mechanism, and installation of the new (replacement) pin.
- 2) Never use any objects other than a buckling pin to hold the mechanism closed during service. Install only replacement buckling pins that are certified by the device manufacturer for use in the mechanism to be reset.
- 3) Do not change/modify the mechanism and pin combination without expressed approval of the manufacturer. Recertification of the device set pressure may be required.
- 4) When reclosing the device, there should be freedom of movement of the mechanism. If excessive force is required, the mechanism can be damaged and is an indication of a blockage in the flow path. If this is the case, the flow path should either be inspected in place or the device should be removed from service to identify and remove the reason for the blockage and resistance to closure.
- 5) Depending on the design, if seals need to be replaced, install only seals supplied by the manufacturer, and follow the manufacturer's seal replacement instructions.
- 6) Maintenance that requires disassembly of the buckling pin-actuated PRD shall be under the direction and guidance of the manufacturer or manufacturer's authorized service representative. Improper reassembly may alter the device set pressure.
- 7) Buckling pins can be removed from service and reinstalled (when the system is depressurized) to check for freedom of movement of the mechanism. Follow the manufacturer's instructions. Do not reinstall a damaged or deflected pin, because this will result in premature opening of the device.
- 8) In instances where components of the device require special lubrication or grease, use only lubricants recommend by the manufacturer.

Annex C (informative)

PRV Acoustic Interaction

C.1 General

This annex describes a method for assessing one acoustic interaction phenomenon with direct spring-loaded PRVs as described in 7.2.4. This technical area is still being researched, so future changes are possible. PRV instability may occur even though this criterion of inlet length limit is satisfied ^[14]^[15].

C.2 Applicability of this Method

PRV and inlet line acoustic interaction depends on the fluid properties, type of PRV, rate of pressurization, speed of PRV opening, and the length of the PRV inlet piping (see 7.2.4 for description). The magnitude of the effect of the acoustic interaction is highly dependent on how quickly the PRV opens (or closes) and the speed of sound in the fluid.

Acoustic line length limits or acoustic analysis can be applied to direct spring-loaded valves in any fluid service.

PRV chatter can occur while relieving vapor, liquid, or two-phase fluids. It is important to note that PRV damage is more likely to occur in liquid service due to the large magnitude of the water hammer pressure waves propagated upstream during rapid valve closure (full or partial), i.e. during chatter or during flutter. Damage can still occur in vapor/two-phase service due to potentially large mechanical forces caused by the rapid valve opening and closing. This may be especially true for large valves and/or for valves in high-pressure service.

Acoustic analysis may not be warranted for the following services because these are lower-risk applications.

- a) any pilot-operated PRV with a remote sense line connected to the protected equipment, because the valve's opening response will be independent of the pressure in the PRV inlet;
- b) any modulating pilot-operated relief valve, because the response speed of a modulating pilot valve is sufficiently slow to allow for the pressure wave to reflect back in time, which would keep the PRV open;
- c) thermal relief valves where the relief load is very small and transient.

C.3 PRV Inlet Acoustic Line Length Limits

If the physical length of the PRV inlet line exceeds the acoustic length as calculated below, instability may occur.

$$L_a = \frac{ct_o}{2} \tag{C.1}$$

where

L_a is the inlet line acoustic length in ft [m];

c is the acoustic velocity (speed of sound in the fluid) in ft/s [m/s];

t_o is the opening time for the PRV in seconds.

This document is not an API Standard; it is under consideration within an API technical committee but has not received all approvals required to become an API Standard. It shall not be reproduced or circulated or quoted, in whole or in part, outside of API committee activities except with the approval of the Chairman of the committee having jurisdiction and staff of the API Standards Dept. Copyright API. All rights reserved.

This is an active area of research, and this simple criterion may not address all forms of instability. Other forms of acoustic interactions with the PRV may require shorter line length criteria (see referenced publications in 7.2.4).

For example, the PRV inlet line length should not exceed 30 ft (9.1 m) for a PRV in liquid service with an opening time of 20 ms where the speed of sound in the liquid is 3000 ft/s (914 m/s).

The PRV inlet line length should be measured from the protected system to the PRV inlet flange, including any process piping used during normal operation that forms part of the pressure relief path to the PRV. Alternatively, the inlet line length may be measured from the PRV inlet flange to the first significant acoustic reflection point. An acoustic reflection point in the piping should be abrupt and have sufficient capacitance to absorb the rarefaction wave. This is described in several texts that cover acoustics, such as *Fundamental of Acoustics*, 4th edition^[17]. Neither an elbow nor a series of reducers are acoustical reflection points. An example of an acoustic reflection point is an abrupt cross-sectional area change where the upstream piping cross-sectional area is approximately 10 or more times larger than the downstream piping cross-sectional area, and the length of the upstream piping is more than 20 times the diameter of the downstream piping (e.g. 3-in.-diameter pipe connected to a 12-in.-diameter pipe that is greater than 80 in. long). In this example, calculations show that this results in about 98 % of the rarefaction wave being absorbed.

C.4 Speed of Sound

The speed of sound is the square root of the partial derivative of pressure with respect to density at constant entropy.

$$c = \sqrt{\left(\frac{\partial P}{\partial \rho}\right)_s}$$

The isentropic bulk modulus may be used to replace the partial derivative, so the speed of sound in the medium may be calculated for liquids as:

in USC units:

$$c = 8.62 \left(\frac{K_s}{S}\right)^{0.5}$$

in SI units:

$$c = \left(\frac{K_s}{S}\right)^{0.5}$$

where

K_s is the isentropic bulk modulus of elasticity for the fluid in psi (kPa)
 (can be calculated from the isothermal bulk modulus of elasticity for the fluid by multiplying by the specific heat ratio, C_p / C_v , for the fluid);

S is the specific gravity of fluid at relieving conditions.

Be aware that values from process simulators for the speed of sound in a fluid, in particular a multicomponent fluid, can be highly variable depending on how the process simulator does the calculation. If a simulator is used to estimate the speed of sound, the method for calculation should be validated against measured speed-of-sound values for common fluids. The user may want to do a sensitivity study to cover a range of values for critical applications.

This document is not an API Standard; it is under consideration within an API technical committee but has not received all approvals required to become an API Standard. It shall not be reproduced or circulated or quoted, in whole or in part, outside of API committee activities except with the approval of the Chairman of the committee having jurisdiction and staff of the API Standards Dept. Copyright API. All rights reserved.

The speed of sound in a fluid is affected by the hoop elasticity of the piping^[32]. The higher the pipe elasticity, the lower the speed of sound is in the fluid, which results in a reduced acoustic line length. For typical steel petrochemical piping, the piping materials and wall thicknesses result in negligible increases in the speed of sound. If, however, the piping material has high elasticity, this effect should be considered.

C.5 Speed of PRV Opening

Spring-loaded PRVs can have very rapid opening times (measured in ms) depending on the valve type, trim, size, set pressure, fluid phase, and pressurization rate. Representative values may be obtained from the PRV manufacturer. In general, measured opening and closing times for PRVs range from 20 to 50 ms depending on the size of the valve. Several references^{[22][31]} are available that provide guidance on how to calculate opening/closing times if this data is not available from the manufacturer. The user may want to do a sensitivity study to cover a range of values for critical applications.

BALLOT DRAFT

This document is not an API Standard; it is under consideration within an API technical committee but has not received all approvals required to become an API Standard. It shall not be reproduced or circulated or quoted, in whole or in part, outside of API committee activities except with the approval of the Chairman of the committee having jurisdiction and staff of the API Standards Dept. Copyright API. All rights reserved.

Bibliography

Informative References

- [1] API Standard 510, *Pressure Vessel Inspection Code: In-Service Inspection, Rating, Repair and Alteration*
- [2] API Standard 526, *Flanged Steel Pressure-relief Valves*
- [3] API Standard 521, *Pressure-Relieving and Depressuring Systems*
- [4] API Recommended Practice 576, *Inspection of Pressure Relieving Devices*
- [5] ASME B31.1¹, *Power Piping*
- [6] ASME B31.3, *Process Piping*
- [7] ASME *Boiler and Pressure Vessel Code*, Section VIII, *Pressure Vessels*

Other References

- [8] Darby R., Chhabra R., "Chemical Engineering Fluid Mechanics," 3rd Edition, 2017, CRC Press
- [9] Melhem, G. A., "Realize Better Risk Characterization of STHE Tube Failure Scenarios through Relief Systems Dynamics Modeling," October 2016, AIChE/DIERS Fall meeting
- [10] Aldeeb, A., Ron Darby, and Scott Arndt, "The dynamic response of pressure-relief valves in vapor or gas service, Part II: Experimental investigation," *Journal of Loss Prevention in the Process Industries*, 2014, 10.1016/j.jlp.2014.06.002
- [11] D'Alessandro, R., "Body Bowl Choking in Pressure-relief Valves," presented at the Joint U.S. and European DIERS Users Group meeting, Hamburg, Germany, June 2011
- [12] Darby, R., "The dynamic response of pressure-relief valves in vapor or gas service, Part I: Mathematical Model," *Journal of Loss Prevention in Process Industries*, Volume 26, 2013, pp. 1262– 1268
- [13] Huff, J. E., "Intrinsic Back Pressure in Safety Valves," API 1983 Refining Meeting, Vol. 62, pp. 105–111, 1983
- [14] Izuchi H., "Chatter of Safety Valve," PLE Technology Center, Chiyoda Advanced Solutions Corporation, April, 2008
- [15] Izuchi, H., "Stability Analysis of Safety Valve," AIChE Spring meeting, April 2010, 10th Topical Conference on Gas Utilization, San Antonio, 2010
- [16] Jenett, E., "Components of Pressure Relieving Systems," *Chemical Engineering*, Volume 70, August 1963, pp. 151–158.
- [17] Kinsler, L. E., et al, *Fundamentals of Acoustics*, 4th Edition, John Wiley & Sons, Inc., 2000

¹ ASME International, Two Park Avenue, New York, New York 10016-5990, www.asme.org.

This document is not an API Standard; it is under consideration within an API technical committee but has not received all approvals required to become an API Standard. It shall not be reproduced or circulated or quoted, in whole or in part, outside of API committee activities except with the approval of the Chairman of the committee having jurisdiction and staff of the API Standards Dept. Copyright API. All rights reserved.

- [18] Melhem, G. A., "Pressure-relief Stability," presented at the Joint US and European DIERS Users Group meeting, Hamburg, Germany, June 2011
- [19] Melhem, G. A., "Screening for PRV Stability—Inlet Pressure Drop and The 3 % Rule," Presented at the 78th API Refining and Equipment Standards Meeting, Las Vegas, NV, April 20–27, 2013
- [20] Melhem, G.A., "Analysis of PRV Stability in Relief Systems, Part II—Screening," Paper presented at the Fall DIERS Users Group Meeting, Mobile, Alabama, October 2014
- [21] Otis, B. "Liquid PRV Instability Team Recommendations," presented to the API 520 Task Force, November, 2011
- [22] "Pressure Drop Considerations on Pressure-relief Valve Inlets," *Consolidated Safety Valves Report* Number CON/PI-10, March 1988
- [23] Richardson, S. M., Saville, G., "Results of Spadeadam experimental validation," In: *Guidelines for the Safe and Optimum Design of Hydrocarbon Pressure-relief and Blowdown Systems*, Editor(s): Hewitt, Institute of Petroleum, 2001. ISBN: 9780852932872
- [24] Singh, A., and Shak, D., "Modeling of a spring loaded safety valve," in *Testing and Analysis of Safety/Relief Valve Performance*, pp. 63–70. American Society of Mechanical Engineers, ASME, 1983.
- [25] Singh, A., Hecht, A. M., and Teske, M. E., "A model for predicting the performance of spring loaded safety valves," in *Testing and Analysis of Safety/Relief Valve Performance*, pp. 47–54. American Society of Mechanical Engineers, ASME, 1983
- [26] Smith, D., and Yoram, S., "Address Inlet Pressure Loss Concerns with Restricted Lift Relief Devices," *Hydrocarbon Processing*, Volume 93, Number 3, March 2014, pp. 71–73
- [27] Sylvander, N. E. and Katz, D. L., *The Design and Construction of Pressure Relieving Systems*, Engineering Research Bulletin No. 31, Engineering Research Institute, University of Michigan Press, April 1948
- [28] *Testing and Analysis of Safety/Relief Valve Performance*, ASME Winter Annual Meeting, Phoenix, AZ, pp. NN–MM, 1983
- [29] Zahorsky, J. R., *Testing and Analysis of Safety/Relief Valve Performance*. The ASME Winter Annual Meeting, Atlanta, GA, November 15–19, 1982
- [30] Hos, C.J., Champneys, A.R., Paul, K., and McNeely, M., "Dynamic Behavior of Direct Spring Loaded Pressure-relief Valves in Gas Service: Model Development, Measurements and Instability Mechanisms," *Journal of Loss Prevention the Process Industries*, Volume 31, pp. 70-81, 2014
- [31] Cremers, J., Friedel, L., and Pallaks, B., "Validated Sizing Rules Against Chatter of Relief Valves During Gas Service," *Journal of Loss Prevention the Process Industries*, Volume 14, pp. 261-267; 2001
- [32] Mays, L., *Hydraulic Design Handbook*, McGraw-Hill, pp. 122, 1999
- [33] Melhem, G.A., "Analysis of PRV Stability in Relief Systems, Part I—Detailed Dynamics," Paper presented at the Fall DIERS Users Group Meeting, Mobile, Alabama, October 2014
- [34] Izuchi, H., "Effect of Body Bowl Choking on Pressure Relief Valve Stability," AIChE Spring meeting, April 2015, 11th Global Congress on Process Safety, Austin, 2015

This document is not an API Standard; it is under consideration within an API technical committee but has not received all approvals required to become an API Standard. It shall not be reproduced or circulated or quoted, in whole or in part, outside of API committee activities except with the approval of the Chairman of the committee having jurisdiction and staff of the API Standards Dept. Copyright API. All rights reserved.

- [35] CCPS, *Guidelines for Pressure Relief and Effluent Handling Systems*, 2nd Edition, 2017, American Institute of Chemical Engineers, Center for Chemical Process Safety, 3 Park Avenue, 19th Floor, New York, New York 10016, www.aiche.org/ccps, ISBN 978-0-470-76773-3

BALLOT DRAFT