

# Specification for Valves

API SPECIFICATION 6D  
TWENTY-FIFTH EDITION, NOVEMBER 2021

API MONOGRAM PROGRAM EFFECTIVE DATE: NOVEMBER 2022

ERRATA 1, DECEMBER 2021

ERRATA 2, APRIL 2022

ERRATA 3, OCTOBER 2023

ADDENDUM 1, APRIL 2023

(API MONOGRAM PROGRAM EFFECTIVE DATE: OCTOBER 2023)

ADDENDUM 2, SEPTEMBER 2024

(API MONOGRAM PROGRAM EFFECTIVE DATE: MARCH 5, 2025)



American  
Petroleum  
Institute

*This document is not an API Standard; it is under consideration within an API technical committee but has not received all approvals required to become an API Standard. It shall not be reproduced or circulated or quoted, in whole or in part, outside of API committee activities except with the approval of the Chairman of the committee having jurisdiction and staff of the API Standards Dept. Copyright API. All rights reserved.*

## **Special Notes**

API publications necessarily address problems of a general nature. With respect to particular circumstances, local, state, and federal laws and regulations should be reviewed. The use of API publications is voluntary. In some cases, third parties or authorities having jurisdiction may choose to incorporate API standards by reference and may mandate compliance.

Neither API nor any of API's employees, subcontractors, consultants, committees, or other assignees make any warranty or representation, either express or implied, with respect to the accuracy, completeness, or usefulness of the information contained herein, or assume any liability or responsibility for any use, or the results of such use, of any information or process disclosed in this publication. Neither API nor any of API's employees, subcontractors, consultants, or other assignees represent that use of this publication would not infringe upon privately owned rights.

API publications may be used by anyone desiring to do so. Every effort has been made by the Institute to assure the accuracy and reliability of the data contained in them; however, the Institute makes no representation, warranty, or guarantee in connection with this publication and hereby expressly disclaims any liability or responsibility for loss or damage resulting from its use or for the violation of any authorities having jurisdiction with which this publication may conflict.

API publications are published to facilitate the broad availability of proven, sound engineering and operating practices. These publications are not intended to obviate the need for applying sound engineering judgment regarding when and where these publications should be utilized. The formulation and publication of API publications is not intended in any way to inhibit anyone from using any other practices.

Any manufacturer marking equipment or materials in conformance with the marking requirements of an API standard is solely responsible for complying with all the applicable requirements of that standard. API does not represent, warrant, or guarantee that such products do in fact conform to the applicable API standard.

Users of this specification should not rely exclusively on the information contained in this document. Sound business, scientific, engineering, and safety judgment should be used in employing the information contained herein.

All rights reserved. No part of this work may be reproduced, translated, stored in a retrieval system, or transmitted by any means, electronic, mechanical, photocopying, recording, or otherwise, without prior written permission from the publisher. Contact the Publisher, API Publishing Services, 200 Massachusetts Avenue, NW, Suite 1100, Washington, DC 20001.

*Copyright © 2021 American Petroleum Institute*

*This document is not an API Standard; it is under consideration within an API technical committee but has not received all approvals required to become an API Standard. It shall not be reproduced or circulated or quoted, in whole or in part, outside of API committee activities except with the approval of the Chairman of the committee having jurisdiction and staff of the API Standards Dept. Copyright API. All rights reserved.*

## **Foreword**

Nothing contained in any API publication is to be construed as granting any right, by implication or otherwise, for the manufacture, sale, or use of any method, apparatus, or product covered by letters patent. Neither should anything contained in the publication be construed as insuring anyone against liability for infringement of letters patent.

The verbal forms used to express the provisions in this document are as follows.

Shall: As used in a standard, “shall” denotes a minimum requirement in order to conform to the standard.

Should: As used in a standard, “should” denotes a recommendation or that which is advised but not required in order to conform to the standard.

May: As used in a standard, “may” denotes a course of action permissible within the limits of a standard.

Can: As used in a standard, “can” denotes a statement of possibility or capability.

This document was produced under API standardization procedures that ensure appropriate notification and participation in the developmental process and is designated as an API standard. Questions concerning the interpretation of the content of this publication or comments and questions concerning the procedures under which this publication was developed should be directed in writing to the Director of Standards, American Petroleum Institute, 200 Massachusetts Avenue, Suite 1100, Washington, DC 20001. Requests for permission to reproduce or translate all or any part of the material published herein should also be addressed to the director.

Generally, API standards are reviewed and revised, reaffirmed, or withdrawn at least every five years. A one-time extension of up to two years may be added to this review cycle. Status of the publication can be ascertained from the API Standards Department, telephone (202) 682-8000. A catalog of API publications and materials is published annually by API, 200 Massachusetts Avenue, Suite 1100, Washington, DC 20001.

Suggested revisions are invited and should be submitted to the Standards Department, API, 200 Massachusetts Avenue, Suite 1100, Washington, DC 20001, standards@api.org.





## Contents

	Page
1 Scope .....	1
2 Normative References .....	1
3 Terms, Definitions, Acronyms, Abbreviations, Symbols, and Units .....	4
3.1 Terms and Definitions .....	4
3.2 Acronyms and Abbreviations .....	10
3.3 Symbols and Units.....	12
4 Application, Configuration, and Performance.....	13
4.1 Valve Types.....	13
4.2 Conformance and General Performance Requirements .....	14
4.3 Pressure and Temperature Rating .....	14
4.4 Valve Bore.....	15
4.5 Manufacturing Processes.....	18
5 Design.....	19
5.1 General .....	19
5.2 Dimensions .....	20
5.3 Drive Train.....	23
5.4 Operations .....	24
5.5 Cavity Relief.....	26
5.6 Body Penetrations.....	27
5.7 Stem Retention .....	28
5.8 Antistatic .....	28
5.9 Lifting.....	28
5.10 Design Process .....	28
6 Materials .....	29
6.1 Metallic Requirements .....	29
6.2 Nonmetallic Requirements .....	30
6.3 Composition Limits.....	30
6.4 Tensile Test Requirements .....	31
6.5 Impact Test .....	31
6.6 Sour Service .....	32
6.7 Body Penetrations.....	32
6.8 Production Heat-treating Equipment .....	32
7 Welding.....	35
7.1 General .....	35
7.2 Outsourced Welding .....	35
7.3 Consumables.....	35
7.4 Qualification.....	35
7.5 Weld Overlay.....	35
7.6 Impact Testing .....	36
7.7 Hardness Testing .....	38
7.8 Visual Inspection—Welds to Pressure-containing Parts .....	38
7.9 Visual Inspection—Pressure-containing and Pipe Pup Welds.....	38
7.10 NDE of Welds Joining Pipe Pups to the Valve .....	38
7.11 Manufacturing Repair .....	39
8 Bolting .....	40
8.1 Pressure-boundary Bolting.....	40
8.2 Other Bolting .....	40
9 Quality Control.....	40
9.1 Measuring and Test Equipment Control .....	40
9.2 Pressure-measuring Device.....	40

**9.3 Welding Inspectors .....41**



9.4	Visual Inspection.....	41
9.5	Storage for Nonmetallic Seals .....	42
9.6	Valve Assembly.....	42
10	Factory Acceptance Testing.....	43
10.1	Pressure Testing—General .....	43
10.2	Stem Backseat Test .....	44
10.3	Hydrostatic Shell Test.....	45
10.4	Hydrostatic Seat Test.....	46
10.5	Hydrostatic Test—Cavity Relief Valve .....	47
11	Coating/Painting.....	48
12	Marking.....	48
12.1	General .....	48
12.2	Valve Size Marking.....	50
12.3	Nameplate .....	50
12.4	Supplemental Requirements .....	52
13	Draining, Protection, and Preparation for Transport.....	52
13.1	Draining.....	52
13.2	Protection.....	52
13.3	Preparation for Transport.....	53
14	Documentation.....	53
14.1	Minimum Documentation and Retention .....	53
14.2	Documentation Provided with the Valve.....	53
	Annex A (informative) Repair or Remanufacture of Valves .....	55
	Annex B (informative) Examples of Valve Configurations.....	71
	Annex C (normative) Valve End-to-end and Face-to-face Dimensions.....	88
	Annex D (informative) Guidance for Travel Stops by Valve Type .....	112
	Annex E (informative) Isolation Valve Features .....	114
	Annex F (informative) Design Validation .....	117
	Annex G (normative) External Coating for End Connectors.....	128
	Annex H (normative) Heat-treat Equipment Qualification .....	131
	Annex I (normative) Quality Specification Level (QSL) and Supplemental Testing .....	134
	Annex J (informative) Requirements for Extended Hydrostatic Shell Test Duration and Records Retention for Valves in Jurisdictional Pipeline Systems.....	145
	Annex K (normative) Purchaser-specified Customization—Permissible Deviations to Specified Design and Manufacturing Requirements.....	147
	Annex L (informative) Specified Customization—Supplemental Options to Specified Design and Manufacturing Requirements .....	150
	Annex M (informative) Valves in Hydrogen (H <sub>2</sub> ) Gas Service .....	162

## Figures

1	Typical Flange Dimension.....	21
2	Bolt-hole Misalignment of Flange Across Valve.....	22
3	Charpy V-notch Weld Metal Specimen Location .....	36
4	Charpy V-notch Heat-affected Zone Specimen Location .....	36
5	Typical Identification Plate for a Valve with One Seat Unidirectional and	

**One Seat Bidirectional.....51**

<b>B.1</b>	<b>Axial Valve</b> .....	<b>71</b>
<b>B.2</b>	<b>Ball Valve (Floating)</b> .....	<b>72</b>
<b>B.3</b>	<b>Ball Valve (Side-entry Trunnion Mounted)</b> .....	<b>73</b>
<b>B.4</b>	<b>Ball Valve (Top-entry Trunnion Mounted)</b> .....	<b>74</b>
<b>B.5</b>	<b>Ball Valve (Welded-body Trunnion Mounted)</b> .....	<b>75</b>
<b>B.6</b>	<b>Check Valve (Axial Flow)</b> .....	<b>76</b>
<b>B.7</b>	<b>Check Valve (Full-opening Swing)</b> .....	<b>77</b>
<b>B.8</b>	<b>Check Valve (Long Pattern, Single-plate Wafer-type)</b> .....	<b>78</b>
<b>B.9</b>	<b>Check Valve (Long Pattern, Typical Dual-plate Wafer-type)</b> .....	<b>79</b>
<b>B.10</b>	<b>Check Valve (Piston)</b> .....	<b>80</b>
<b>B.11</b>	<b>Check Valve (Reduced-opening Swing)</b> .....	<b>81</b>
<b>B.12</b>	<b>Check Valve (Short Pattern, Single-plate Wafer-type)</b> .....	<b>82</b>
<b>B.13</b>	<b>Gate Valve (Expanding-gate/Rising-stem)</b> .....	<b>83</b>
<b>B.14</b>	<b>Gate Valve (Slab-gate/Through-conduit Rising-stem)</b> .....	<b>84</b>
<b>B.15</b>	<b>Plug Valve</b> .....	<b>85</b>
<b>B.16</b>	<b>Rising Stem Ball Valve</b> .....	<b>86</b>
<b>E.1</b>	<b>Block and Bleed—Type A</b> .....	<b>113</b>
<b>E.2</b>	<b>Block and Bleed—Type B</b> .....	<b>113</b>
<b>E.3</b>	<b>Double Block and Bleed—Type A</b> .....	<b>113</b>
<b>E.4</b>	<b>Double Block and Bleed—Type B</b> .....	<b>114</b>
<b>E.5</b>	<b>Double Isolation and Bleed—Type A</b> .....	<b>114</b>
<b>E.6</b>	<b>Double Isolation and Bleed—Type B</b> .....	<b>114</b>
<b>F.1</b>	<b>Test Procedure for Pressure Temperature Cycle</b> .....	<b>124</b>
<b>G.1</b>	<b>Raised Face</b> .....	<b>126</b>
<b>G.2</b>	<b>Ring Type Joint or Raised-face Ring Type Joint</b> .....	<b>127</b>
<b>G.3</b>	<b>Weld End</b> .....	<b>127</b>
<b>G.4</b>	<b>Pipe Pup Weld Ends</b> .....	<b>128</b>
<b>H.1</b>	<b>Thermocouple Locations—Rectangular Furnace (Working Zone)</b> .....	<b>129</b>
<b>H.2</b>	<b>Thermocouple Locations—Cylindrical Furnace (Working Zone)</b> .....	<b>130</b>
<b>L.1</b>	<b>Pressure Balance Hole for Ball Valve (Typical)</b> .....	<b>157</b>
<b>L.2</b>	<b>Pressure Balance Hole for Gate Valve (Typical)</b> .....	<b>157</b>
<b>Tables</b>		
<b>1</b>	<b>Minimum Bore for Full-opening Valves</b> .....	<b>17</b>
<b>2</b>	<b>Process Control Requirements</b> .....	<b>18</b>
<b>3</b>	<b>Sizes for Drain</b> .....	<b>27</b>
<b>4</b>	<b>Minimum V-notch Impact Requirements for Material other than Duplex and Super Duplex Stainless Steel (Full-size Specimen)</b> .....	<b>31</b>
<b>5</b>	<b>Minimum V-notch Impact Requirements for Duplex and Super Duplex Stainless Steel (Full-size Specimen)</b> .....	<b>31</b>

**6 Adjustment Factors for Subsize Impact Specimens.....32**

<b>7</b>	<b>Heat Treatment Thermal Uniformity Survey (TUS) Requirements</b> .....	<b>33</b>
<b>8</b>	<b>Minimum Duration of Stem Backseat Tests</b> .....	<b>43</b>
<b>9</b>	<b>Minimum Duration of Hydrostatic Shell Tests</b> .....	<b>44</b>
<b>10</b>	<b>Minimum Duration of Hydrostatic Seat Tests</b> .....	<b>45</b>
<b>11</b>	<b>Valve Marking on Body</b> .....	<b>48</b>
<b>12</b>	<b>Additional Marking</b> .....	<b>49</b>
<b>13</b>	<b>Valve Marking on Nameplate</b> .....	<b>50</b>
<b>A.1</b>	<b>Initial Inspection</b> .....	<b>56</b>
<b>A.2</b>	<b>Items for Photographic Inspection</b> .....	<b>56</b>
<b>A.3</b>	<b>Disassembly of Ball Valve with Seat Leakage</b> .....	<b>58</b>
<b>A.4</b>	<b>Requirements for Evaluation of Components</b> .....	<b>60</b>
<b>A.5</b>	<b>Requirements for Replacement Parts of Non-OEM Parts</b> .....	<b>65</b>
<b>A.6</b>	<b>Nameplate Marking Requirements</b> .....	<b>68</b>
<b>C.1</b>	<b>Axial Valves—Face-to-face (A) and End-to-end (B and C) Dimensions</b> .....	<b>88</b>
<b>C.2</b>	<b>Ball Valves—Side-Entry and Top-Entry, Face-to-face (A), and End-to-end (B and C) Dimensions</b> .....	<b>91</b>
<b>C.3</b>	<b>Check Valves and Axial Check Valves (Full Opening and Reduced Types)—Face-to-face (A) and End-to-end (B and C) Dimensions</b> .....	<b>96</b>
<b>C.4</b>	<b>Check Valves (Single- and Dual-plate, Long- and Short-pattern, Wafer-type, and Double Flanged)—Face-to-face Dimensions</b> .....	<b>101</b>
<b>C.5</b>	<b>Gate Valves—Face-to-face (A) and End-to-end (B and C) Dimensions</b> .....	<b>103</b>
<b>C.6</b>	<b>Plug Valves—Face-to-face (A) and End-to-end (B and C) Dimensions</b> .....	<b>106</b>
<b>D.1</b>	<b>Valve Travel Stops</b> .....	<b>111</b>
<b>E.1</b>	<b>Isolation Valve Types</b> .....	<b>112</b>
<b>F.1</b>	<b>Design Validation for Valves</b> .....	<b>121</b>
<b>F.2</b>	<b>Minimum Percentage of Pressure During Opening Phase</b> .....	<b>122</b>
<b>I.1</b>	<b>NDE Requirements</b> .....	<b>133</b>
<b>I.2</b>	<b>Extent, Method, and Acceptance Criteria of NDE/Item Examination Code</b> .....	<b>134</b>
<b>I.3</b>	<b>Production Materials Requirements</b> .....	<b>135</b>
<b>I.4</b>	<b>Testing Sequence for Quality Specification Levels</b> .....	<b>136</b>
<b>I.5</b>	<b>Minimum Duration of Gas Shell Tests</b> .....	<b>140</b>
<b>I.6</b>	<b>Documentation Requirements for Each QSL</b> .....	<b>142</b>
<b>L.1</b>	<b>Stabilization Period Duration</b> .....	<b>154</b>
<b>L.2</b>	<b>Minimum Duration of Gas Shell Tests</b> .....	<b>155</b>
<b>M.1</b>	<b>Summary of Specification Level Requirements for Hydrogen</b> .....	<b>161</b>
<b>M.2</b>	<b>Fugitive Emission Test Acceptance Criteria—Helium Gas</b> .....	<b>170</b>
<b>M.3</b>	<b>Fugitive Emission Test Acceptance Criteria—Forming Gas</b> .....	<b>170</b>



## **Introduction**

### **Changes from the 24<sup>th</sup> to the 25<sup>th</sup> Edition**

This specification is the result of updating the requirements from API Specification 6D, 24th Edition, including Addendum 1 and Addendum 2. The revision of API 6D, 25th Edition, was developed based on input from the API 6D Task Group technical experts globally. The technical revisions have been made to accommodate the needs of industry and address many interpretations to move this specification to a higher level of service to the petroleum and natural gas industry. Highlights of some of the significant changes between the 24<sup>th</sup> edition and 25<sup>th</sup> edition, include:

- changing the title of the specification;
- reorganizing the specification requirements in an order more aligned with the manufacturing process;
- the addition of axial valves to the types of valves covered by this specification;
- the removal of Class 400 as a standard pressure class;
- requiring conformance to API 6DX for valves supplied with actuators;
- identifying allowable adjustments for subsized impact specimens;
- identifying minimum heat treatment requirements;
- identifying minimum bolting requirements;
- revising marking requirements;
- providing updated design validation guidance;
- addition of requirements for repair and remanufacture of valves from API 6DR in new Annex A;
- collecting all purchaser-specified requirements into annexes (Annex K and Annex L);
- combining QSL requirements from the 24<sup>th</sup> edition (Annexes I, J, and H into one annex [Annex I]);
- adding guidance throughout the document reference to API 20 series specifications and standards.

### **Units of Measurement**

In this standard, data are expressed in both U.S. customary (USC) and metric (SI) units.

### **Rounding**

Except as otherwise required by this specification, to determine conformance with the specified requirements, observed or calculated values are rounded to the nearest unit in the last right-hand place of figures used in expressing the limiting value, in conformance with the rounding method of ASTM E29 or ISO 80000-1, Annex B, Rule A.





# Specification for Valves

## 1 Scope

This specification defines the requirements for the design, manufacturing, materials, welding, quality control, assembly, testing, marking, documentation, and process controls of axial, ball, check, gate, and plug valves for application in the petroleum and natural gas industries, and hydrogen gas service.

This specification applies to ASME Class 150, 300, 600, 900, 1500, and 2500.

NOTE ASME Class 400 has been removed from this specification.

API 6DR for repair and remanufacture of valves has been withdrawn and has been replaced by Annex A.

Annexes A, B, D, E, F, J, L, and M are informative and contain optional requirements used in this specification.

Annexes C, G, H, I, and K are normative and are mandatory in the use of this specification.

Information marked "NOTE" are not requirements but are provided for guidance in understanding or clarifying the associated requirement.

## 2 Normative References

The following referenced documents are indispensable for the application of this document. For dated references, only the edition cited applies. For undated references, the latest edition of the referenced document (including any amendments) applies, ~~except that new editions may be used on issue and shall become mandatory upon the effective date specified by the publisher or 6 months from the date of the revision (where no effective date is specified).~~

### AMPP (formerly NACE)<sup>1</sup>

NACE MR0175/ISO15156 (all parts), *Petroleum and natural gas industries—Materials for use in H<sub>2</sub>S-containing environments in oil and gas production*

### API

API Standard 6ACRA, *Age-hardened Nickel-based Alloys for Oil and Gas Drilling and Production Equipment*

API Standard 6DX, *Standard for Actuators and Mounting Kits for Valves*

API Specification 6FA, *Specification for Fire Test for Valves*

API Specification 20A, *Carbon Steel, Alloy Steel, Stainless Steel, and Nickel Base Alloy Castings for Use in the Petroleum and Natural Gas Industry*, ~~2<sup>nd</sup> Edition~~

API Specification 20B, *Open Die Shaped Forgings for Use in the Petroleum and Natural Gas Industry*, ~~1<sup>st</sup> Edition~~

---

<sup>1</sup> Association for Material Protection and Performance (formerly NACE International), 1440 South Creek Drive, Houston, Texas 77084-4906, www.nace.org.

API Specification 20C, *Closed Die Forgings for Use in the Petroleum and Natural Gas Industry*, ~~3<sup>rd</sup> Edition~~

API Specification 20E, *Alloy and Carbon steel bolting for Use in the Petroleum and Natural Gas Industries*, ~~2<sup>nd</sup> Edition~~

API Specification 20F, *Corrosion-resistant Bolting for use in the Petroleum and Natural Gas Industries*, ~~2<sup>nd</sup> Edition~~

API Standard 607, *Fire Test for Quarter-turn Valves and Valves Equipped with Nonmetallic Seats*

API Standard 624, *Type Testing of Rising Stem Valves Equipped with Graphite Packing for Fugitive Emissions*

API Standard 641, *Type Testing of Quarter-turn Valves for Fugitive Emissions*

## **ASME<sup>2</sup>**

ASME B1.1, *Unified Inch Screw Threads (UN and UNR Thread Form)*

ASME B1.20.1, *Pipe Threads, General Purpose (Inch)*

ASME B16.5, *Pipe Flanges and Flanged Fitting: NPS 1/2 through 24*

ASME B16.10, *Face-to-Face and End-to-End Dimensions of Valves*

ASME B16.25, *Buttwelding Ends*

ASME B16.34, *Valves—Flanged, Threaded, and Welding End*

ASME B16.47, *Large Diameter Steel Flanges: NPS 26 through NPS 60 Metric/Inch Standard*

ASME B18.2.2, *Nuts for General Applications: Machine Screw Nuts, Hex, Square, Hex Flange, and Coupling Nuts (Inch Series)*

ASME B31.4, *Pipeline Transportation Systems for Liquid Hydrocarbons and Other Liquids*,

ASME B31.8, *Gas Transmission and Distribution Piping Systems*

ASME Boiler and Pressure Vessel Code (BPVC), Section II: *Materials, Part D: Properties*

ASME Boiler and Pressure Vessel Code (BPVC), Section V: *Nondestructive Examination*

ASME Boiler and Pressure Vessel Code (BPVC), Section VIII: *Rules for Construction of Pressure Vessels; Division 1: Rules for Construction of Pressure Vessels*

ASME Boiler and Pressure Vessel Code (BPVC), Section VIII: *Rules for Construction of Pressure Vessels; Division 2: Alternative Rules*

ASME Boiler and Pressure Vessel Code (BPVC), Section IX: *Welding and Brazing Qualifications*

## **ASNT<sup>3</sup>**

---

<sup>2</sup> ASME International, 2 Park Avenue, New York, New York 10016-5990, [www.asme.org](http://www.asme.org).

<sup>3</sup> American Society for Nondestructive Testing, 1711 Arlingate Lane, P.O. Box 28518, Columbus, Ohio 43228, [www.asnt.org](http://www.asnt.org).

ASNT SNT-TC-1A, *Personnel Qualification and Certification in Non-Destructive Testing*

#### **ASTM<sup>4</sup>**

ASTM A320/A320M, *Standard Specification for Alloy-Steel and Stainless Steel Bolting Materials for Low-Temperature Service*

ASTM A370/A370M, *Standard Test Methods and Definitions for Mechanical Testing of Steel Products*

ASTM A488/A488M, *Standard Practice for Steel Castings, Welding, Qualifications of Procedures and Personnel*

ASTM A578A/A578M, *Standard Specification for Straight-Beam Ultrasonic Examination of Rolled Steel Plates for Special Applications*

ASTM A609/A609M, *Standard Practice for Castings, Carbon, Low-Alloy, and Martensitic Stainless Steel, Ultrasonic Examination Thereof*

ASTM A962/A962M, *Standard Specification for Common Requirements for Steel Fasteners or Fastener Materials, or Both, Intended for Use at Any Temperature from Cryogenic to the Creep Range*

ASTM E10, *Standard Test Method for Brinell Hardness of Metallic Materials*

ASTM E18, *Standard Test Methods for Rockwell Hardness of Metallic Materials*

ASTM E110, *Standard Test Method for Rockwell and Brinell Hardness of Metallic Materials by Portable Hardness Testers*

#### **ISO<sup>5</sup>**

ISO 148-1, *Metallic materials—Charpy pendulum impact test—Part 1: Test method*

ISO 228-1, *Pipe threads where pressure-tight joints are not made on the threads—Part 1: Dimensions, tolerances and designation*

ISO 3601-2, *Fluid power systems—O-rings—Part 2: Housing dimensions for general applications*

ISO 3601-3, *Fluid power systems—O-rings—Part 3: Quality acceptance criteria*

ISO 5208, *Industrial valves—Pressure testing of valves*

ISO 9606-1, *Approval testing of welders—Fusion welding—Part 1: Steels*

ISO 9712, *Non-destructive testing—Qualification and certification of personnel*

ISO 10497, *Testing of valves— Fire type-testing requirements*

ISO 14732, *Welding personnel — Qualification testing of welding operators and weld setters for mechanized and automatic welding of metallic materials*

ISO TR 15608, *Welding—Guidelines for a metallic materials grouping system*

---

<sup>4</sup> ASTM International, 100 Barr Harbor Drive, West Conshohocken, Pennsylvania 19428, [www.astm.org](http://www.astm.org).

<sup>5</sup> International Organization for Standardization, 1, ch. de la Voie-Creuse, Case postale 56, CH-1211 Geneva 20, Switzerland, [www.iso.org](http://www.iso.org).

ISO 15609 (all parts), *Specification and qualification of welding procedures for metallic materials—Welding procedure specification*

ISO 15614-1, *Specification and qualification of welding procedures for metallic materials—Welding procedure test—Part 1: Arc and gas welding of steels and arc welding of nickel and nickel alloys*

ISO 15614-7, *Specification and qualification of welding procedures for metallic materials—Welding procedure test—Part 7: Overlay welding*

ISO 15848-1, *Industrial valves—Measurement, test and qualification procedures for fugitive emissions—Part 1: Classification system and qualification procedures for type testing of valves*

ISO 15848-2, *Industrial valves—Measurement, test and qualification procedures for fugitive emissions—Part 2: Production acceptance test of valves*

ISO 23936-1, *Petroleum, petrochemical and natural gas industries—Non-metallic materials in contact with media related to oil and gas production—Part 1: Thermoplastics*

ISO 23936-2, *Petroleum, petrochemical and natural gas industries—Non-metallic materials in contact with media related to oil and gas production—Part 2: Elastomers*

## **MSS<sup>6</sup>**

MSS SP-25, *Standard Marking System for Valves, Fittings, Flanges, and Unions*

MSS SP-44, *Steel Pipeline Flanges*

MSS SP-55, *Quality Standard for Steel Castings for Valves, Flanges and Fittings and Other Piping Components—Visual Method for Evaluation of Surface Irregularities*

## **SAE<sup>7</sup>**

SAE AMS-H-6875, *Heat Treatment of Steel Raw Materials*

SAE AMS2750, *Pyrometry*

# **3 Terms, Definitions, Acronyms, Abbreviations, Symbols, and Units**

## **3.1 Terms and Definitions**

For the purposes of this document, the following definitions apply.

### **3.1.1**

#### **assembly**

An association of multiple parts/components into a finished product, including, at a minimum, installation of all pressure-containing and pressure-controlling parts.

### **3.1.2**

#### **bidirectional seat**

A valve seat designed to seal against a pressure source in either direction.

---

<sup>6</sup> Manufacturers Standardization Society of the Valve and Fittings Industry, Inc., 127 Park Street, NE, Vienna, Virginia 22180- 4602, [www.mss-hq.com](http://www.mss-hq.com).

<sup>7</sup> SAE Headquarters, 400 Commonwealth Drive, Warrendale, PA 15096

**3.1.3****bidirectional valve**

A valve designed for blocking the flow from either the upstream or the downstream direction.

**3.1.4****bleed (verb)**

To drain or vent.

**3.1.5****block and bleed valve****BB**

A valve with at least one seating surface that, in the closed position, provides a seal against pressure from one end of the valve with the other end depressurized.

**3.1.6****block valve**

An axial, check, ball, gate, or plug valve that blocks flow when in the closed position.

NOTE Valves may be either single-seated or double-seated or either bidirectional or unidirectional.

**3.1.7****breakaway thrust****breakaway torque**

The maximum thrust or torque required to operate a valve at maximum pressure differential.

**3.1.8****by agreement**

A contractual requirement between the manufacturer and the purchaser needed for a given action to be completed.

**3.1.9****casting (noun)**

An object at or near finished shape obtained by solidification of a fluid substance in a mold.

NOTE Objects made by hot isostatic pressing are not castings.

**3.1.10****closure member**

Part of a valve, such as a ball, clapper, disc, gate, piston, or plug, positioned in the flow stream to permit or prevent flow.

NOTE Earlier editions of API 6D referred to the closure member as an "obturator."

**3.1.11****corrosion-resistant****corrosion-resistant alloy**

An alloy (or material) intended to be resistant to general and localized corrosion and/or environmental cracking in environments that are corrosive to carbon and low-alloy steels

**3.1.12****date of manufacture**

The month and year of completion of factory acceptance testing.

**3.1.13****design review and verification**

The process of examining the result of design and development output to determine conformity with specified requirements.

NOTE Design verification activities can include one or more of the following (this is not an all-inclusive list):

- a) confirming the accuracy of design results through the performance of alternative calculations;
- b) review of design output documents independent of activities of design and development;
- c) comparing new designs to similar proven designs.

### **3.1.14 design validation**

The process of proving a design by testing to demonstrate conformity of the product to design requirements.

NOTE Design validation can include one or more of the following (this is not an all-inclusive list):

- a) prototype tests;
- b) functional and/or operational tests of production products;
- c) tests specified by industry standards and/or regulatory requirements;
- d) field performance tests and reviews.

### **3.1.15 double block and bleed valve DBB**

A valve with two or more seating surfaces that, in the closed position, provides a seal against pressure from both ends of the valve with a means of venting/bleeding the cavity between the seating surfaces.

### **3.1.16 double isolation and bleed valve DIB**

A valve with two or more seating surfaces, each of which, in the closed position, provide a seal against pressure from a single source, with a means of venting/bleeding the cavity between the seating surfaces.

NOTE This feature can be provided in one direction or in both directions.

### **3.1.17 drive train**

All parts of a valve drive from the operator to and including the closure member connection that transmit or react to loads.

### **3.1.18 flow coefficient**

$C_v$

The volumetric flow rate of U.S. gallons of water per minute at a temperature of 60 °F (15.6 °C) passing through a valve and resulting in a pressure loss of 1 psi (0.0069 MPa; 0.069 bar).

### **3.1.19 hand-wheel**

A part used to manually operate a valve requiring turning and consisting of a rim connected to a hub.

### **3.1.20 locking device**

A part or an arrangement of parts for securing a valve in the open or closed position.

**3.1.21****manufacturer**

An organization, facility, or individual that satisfies the requirements of this specification.

NOTE See 4.5.1 for activities that may be outsourced.

**3.1.22****maximum allowable working pressure****MAWP**

The maximum pressure at which the valve is designed to operate, at a corresponding temperature, as defined by ASME B16.34.

NOTE Pressure–temperature ratings are the maximum allowable working pressure for the corresponding temperature.

**3.1.23****maximum allowable stem torque/thrust****MAST**

The maximum torque/thrust that can be applied to the valve drive train without damage, as defined by the valve manufacturer.

**3.1.24****maximum pressure differential****MPD**

The maximum difference between the upstream and downstream pressure across the closure member at which the closure member may be operated.

**3.1.25****nominal [diameter] size****DN**

A numerical designation of size (in millimeters) that is common to components in piping systems.

**3.1.26****nominal pipe size****NPS**

A numerical designation of size (in inches) that is common to components in piping systems.

**3.1.27****operator**

An individual device or assembly for opening and closing a valve that may be controlled manually or under separate power (electric, hydraulic, or gas-driven).

NOTE 1 A manual operator can be a wrench (lever) or hand-wheel with or without a gearbox.

NOTE 2 A powered operator can include an actuator, a gearbox, and/or direct drive device.

**3.1.28****outsourced**

A function, activity, or process that is performed by an external supplier on behalf of the manufacturer.

**3.1.29****packing gland**

Components that are used to compress/retain the stem packing.

**3.1.30****pipe pup****transition piece**

A piece of pipe or forged material that is welded to the finished valve body.

**3.1.31****position indicator**

A device that shows the position of the valve closure member.

**3.1.32****pressure balance hole****pressure equalization hole**

An opening in the closure member that provides pressure balance between the valve bore and valve cavity only when in the open position.

NOTE The hole does not provide relief of cavity overpressure in the closed position.

**3.1.33****pressure-boundary bolting**

A threaded fastener used to assemble pressure-containing parts.

EXAMPLE Pressure boundary bolting can include studs, nuts, bolts, and cap screws.

**3.1.34****pressure class**

A numerical designation as defined in ASME B16.34 that also defines the pressure and temperature rating for the end connector material of the valve.

NOTE The ASME rating class (pressure rating designation) is composed of the word "Class," followed by a dimensionless number (the designation for pressure-temperature ratings); for example: Class 150, Class 300, etc.

**3.1.35****pressure-containing parts**

Parts such as those identified in 5.1.2 whose failure to function as intended results in a release of contained fluid into the environment.

NOTE Pressure-containing parts do not include bolting (see Section 8).

**3.1.36****pressure-controlling parts**

Parts such as those identified in 5.1.3 that are intended to allow or prevent the flow of fluids.

**3.1.37****purchaser**

An organization, facility, or individual that buys equipment from the manufacturer.

**3.1.38****remanufacturer**

An organization, facility, or individual performing disassembly, reassembly, and testing of a valve with or without replacement of parts that includes machining, welding, heat-treating, and/or other manufacturing operations, but without replacement of the body, performed in conformance with this specification.

**3.1.39****repairer**

An organization, facility, or individual performing disassembly, reassembly, and testing of a valve with or without replacement of parts that does not include machining, welding, and heat-treating, other manufacturing operations, or replacement of bodies performed in conformance with this specification.

NOTE Repair processes can include buffing, polishing, deburring, and other minimal removal processes.



**3.1.40****sealing surface**

The contact surface of dynamic or static seals within the valve shell, excluding end connector sealing surfaces that mate with other equipment.

EXAMPLE Sealing surface examples include the stem, seat, cover/bonnet seals, and backseat.

**3.1.41****seating surfaces**

Contact surfaces of the closure member and seat that affect valve sealing.

NOTE The seat may be integral to the valve body.

**3.1.42****self-relieving seat**

A valve seat designed to relieve pressure from the valve cavity.

NOTE Depending upon valve type, the pressure may be relieved to the pressure source or the low-pressure side.

**3.1.43****shaft**

A part that supports the closure member on a check valve and that may or may not pass through the pressure-boundary.

**3.1.44****shell test**

A test of the assembled pressure-containing parts.

**3.1.45****stem**

A part that, when present, drives the closure member and passes through the pressure-boundary.

**3.1.46****stem extension assembly**

A non-pressure-containing assembly consisting of the stem extension and the stem extension housing.

**3.1.47****temperature, maximum allowable**

The upper limit for a valve based on continuous operating service conditions.

NOTE 1 The maximum operating temperature may be limited by pressure.

NOTE 2 Pressure-temperature ratings are the maximum allowable working pressure for the corresponding temperature.

**3.1.48****temperature, minimum allowable**

The lower limit for a valve based on continuous operating service conditions.

NOTE The minimum operating temperature may be limited by pressure.

**3.1.49****through-conduit valve**

A valve with an unobstructed and continuous cylindrical opening.

**3.1.50****unidirectional seat**

A valve seat designed to seal the pressure source in one direction only.

**3.1.51****unidirectional valve**

A valve designed for blocking the flow in one direction only.

**3.1.52****unless otherwise agreed**

A provision to permit modification of a requirement of this specification, only where the requirement includes this term and only when the manufacturer and purchaser are in agreement regarding the modification.

**3.1.53****upstream**

The side of the valve closer to the source of pressure.

NOTE Downstream is the opposite side of the seat-to-closure member.

**3.1.54****visible leakage**

Leakage of test fluid observed by any visual method during a pressure test.

**3.2 Acronyms and Abbreviations**

For the purposes of this document, the following acronyms and abbreviations apply.

ACCP	ASNT Central Certification Program
AMPP	Association for Material Protection and Performance
API	American Petroleum Institute
ASNT	American Society for Nondestructive Testing
ASME	American Society for Mechanical Engineers
ASTM	American Society for Testing and Materials
AWS	American Welding Society
BB	block and bleed
BM	base metal
BPVC	Boiler and Pressure Vessel Code
BSL	bolting specification level
BTC	break-to-close
BTO	break-to-open
CE	carbon equivalent
CRA	corrosion-resistant alloy
DBB	double block and bleed
DIB	double isolation and bleed

---

DN	nominal size
DPE	double piston effect
ETC	end-to-close
ETO	end-to-open
FAT	factory acceptance test
HAZ	heat-affected zone
HBW	Brinell hardness, tungsten ball indenter
HRC	Rockwell C hardness
HVOF	High Velocity Oxygen Fuel
ID	inner/inside diameter
ISO	International Standards Organization
MAWP	maximum allowable working pressure
MAST	maximum allowable stem torque/thrust
MPD	maximum pressure differential
MSS	Manufacturers Standardization Society
MT	magnetic-particle testing
NDE	nondestructive examination
NACE	formerly National Association of Corrosion Engineers
NORM	naturally occurring radioactive material
NPS	nominal pipe size
NPT	national pipe taper
OD	outer/outside diameter
OEM	original equipment manufacturer
PMI	positive material identification
PQR	(weld) procedure qualification record
PT	penetrant testing
PWHT	post-weld heat treatment
QSL	quality specification level
RGD	rapid gas decompression

RT	radiographic testing
RTC	run-to-close
RTO	run-to-open
SAE	Society of Automotive Engineers
SDS	safety data sheet
SLH	specification level for hydrogen
SMYS	specified minimum yield strength
SPE	single piston effect
SWL	safe working limit
TC	test coupon
TPI	threads per inch
TUS	thermal uniformity survey
UNC	Unified National Coarse
UT	ultrasonic testing
VT	visual testing
WM	weld metal
WPS	weld procedure specification

### 3.3 Symbols and Units

For the purposes of this document, the following symbols and units apply.

$C_V$	flow coefficient in USC units
$K_V$	flow coefficient in SI (metric) units
ppm	part per million (mass)
$S_m$	design stress intensity value
$S_y$	[specified minimum] yield strength
$t$	thickness
V	volts, direct current
$\Omega$	ohms

## 4 Application, Configuration, and Performance

### 4.1 Valve Types

#### 4.1.1 General

This specification shall apply to the following:

- axial valves;
- ball valves;
- check valves;
- gate valves;
- plug valves.

NOTE The nomenclature used in this specification for typical equipment is shown in Figures B.1 thru B.15.

Valves having a preferred flow direction for operation shall be marked per Table 12.

#### 4.1.2 Axial Valves

Axial valves shall have a closure member that moves on an axis parallel to the direction of flow.

NOTE A typical configuration for axial valves with flanged or weld ends is shown, for illustration purposes only, in Figure B.1. Other configurations for this valve type are possible.

#### 4.1.3 Ball Valves

Ball valves shall have a solid, one-piece nominally spherical closure member that rotates on an axis perpendicular to the direction of flow.

NOTE Typical configurations for ball valves with flanged or weld ends are shown, for illustration purposes only, in Figures B.2 through B.5. Other configurations for this valve type are possible.

#### 4.1.4 Check Valves

Check valves shall have a closure member that responds automatically to block fluid in one direction and to permit fluid flow in the opposite direction.

NOTE 1 Typical configurations for check valves are shown, for illustration purposes only, in Figures B.6 through B.12. Other configurations for this valve type are possible.

NOTE 2 Check valves may be supplied with a lock-open feature that would prevent the automatic blocking of fluid flow.

#### 4.1.5 Gate Valves

Gate valves shall have a closure member that moves in a plane perpendicular to the direction of flow.

NOTE 1 The closure member can be constructed of one piece (slab-gate valve) or of two or more pieces (expanding-gate valve).

Gate valves shall be provided with a backseat or secondary stem sealing feature in addition to the primary stem seal.

NOTE 2 Typical configurations for gate valves with flanged and weld ends are shown, for illustration purposes only, in Figures B.13 and Figure B.14. Other configurations for this valve type are possible.

#### 4.1.6 Plug Valves (Lubricated and Non-lubricated)

Plug valves shall have a cylindrical or conical closure member that rotates about an axis perpendicular to the direction of flow.

NOTE A typical configuration for plug valves with flanged and weld ends is shown, for illustration purposes only, in Figure B.15. Other configurations for this valve type are possible.

## 4.2 Conformance and General Performance Requirements

Valves conforming to this specification shall be manufactured under the manufacturer's quality management system, which shall conform to an industry-accepted standard such as API Q1 or ISO 9001.

For the manufacture of valves under this specification, requirements from all reference documents in Section 2 in effect at the time of publication of this specification are mandatory by the effective date of this specification. Requirements that are specified from an undated reference document identified in Section 2 that has been published after the effective date of this specification may be implemented at any time after publication of the newly issued reference document but a delayed implementation of those requirements of up to 12 months after the effective date of the reference document shall be permitted. Thereafter, all requirements from newly issued reference documents identified in Section 2 shall become mandatory by 12 months after the effective date of the reference document.

Designs shall conform to 5.10.

Only testing and NDE requirements identified in Section 4 through Section 14 shall apply to valves manufactured to this specification. The supplemental testing and quality specification levels of Annex I shall apply when specified by the purchaser.

NOTE 1 Annex I identifies supplemental requirements for nondestructive examination and pressure testing that may be performed on a valve when specified by the manufacturer or purchaser.

Applicable requirements as stated in Section 4 through Section 14 shall apply to valves manufactured to this specification without modification unless otherwise specified in accordance with the allowances in Annex K. The acceptable deviations as identified in Annex K shall apply when specified by the purchaser.

NOTE 2 Annex K identifies allowable modifications that may be applied to valves when specified by the purchaser. Valves manufactured with any allowed modification in accordance with Annex K conform to this specification.

The supplemental requirements in Annex L and Annex M shall apply when specified by the manufacturer and/or purchaser.

NOTE 3 Annex L and Annex M identify allowable additions or supplements to the requirements in Section 4 through Section 14 that may be applied to valves when specified by the manufacturer or purchaser. Valves manufactured with any allowed addition or supplement in accordance with Annex L and/or Annex M conform to this specification.

## 4.3 Pressure and Temperature Rating

### 4.3.1 Standard Valves—ASME Pressure Class

Standard valves covered by this specification shall be furnished in one of the following pressure classes (see 3.1.34):

— Class 150;

- Class 300;
- Class 600;
- Class 900;
- Class 1500;
- Class 2500.

Pressure-temperature ratings for class-rated valves shall conform to the rating table for the applicable material group per ASME B16.34.

The pressure-temperature rating applied shall be based on the material group of the valve end connector. Where the valve ends are made from material in two different groups, the material with the lower pressure-temperature rating shall determine the rating.

NOTE Different material or material forms may be used for body and bonnet or cover parts within the same valve.

All metallic pressure-containing and pressure-controlling parts shall be designed to meet the identified valve pressure-temperature rating.

The manufacturer shall determine any limits on the maximum allowable working pressure (MAWP) and shall identify the minimum and maximum allowable temperatures resulting from the nonmetallic parts used.

#### **4.3.2 Non-standard Valves—Pressures and Temperatures**

Non-standard valves with intermediate pressure and temperature ratings shall conform to K.2.

Intermediate pressure and temperature ratings shall not be applied to valves with ASME flanged ends (see K.2).

Pressure-temperature ratings for valves made from materials not listed in ASME B16.34 shall be determined, up to the temperature limitation of the valve, using the methods defined in ASME B16.34, in accordance with 5.1, or per MSS SP-44.

### **4.4 Valve Bore**

#### **4.4.1 Nominal Size**

Valves manufactured to this specification shall conform to either:

- nominal size as listed in Table 1; or
- size and bore determined by agreement when no size or minimum bore dimension is listed in Table 1 (see K.3.1).

NOTE Weld-end valves may require a smaller diameter at the weld end to mate with the pipe.

#### **4.4.2 Full-opening Valves**

Full-opening valves shall be unobstructed in the fully opened position and shall have an internal minimum circular opening of the closure member and seat as specified in Table 1.

When pipe is used in the construction of the valves, the pipe shall meet the tolerances of the applicable pipe specification.

Valves with a noncircular opening through the closure member shall not be identified as full opening.

#### **4.4.3 Reduced-opening Valves with a Circular Opening**

Reduced-opening valves with a circular opening through the closure member shall conform to one of the following:

- a) valves NPS 4 (DN 100) to NPS 12 (DN 300): one size below nominal size of valve with bore according to Table 1;
- b) valves NPS 14 (DN 350) to NPS 24 (DN 600): one or two sizes below nominal size of valve with bore according to Table 1;
- c) valves that do not conform to 4.4.3.a or 4.4.3.b: see K.3.2;
- d) valve sizes less than NPS 4 (DN 100) or greater than NPS 24 (DN 600) conforming to L.2.

EXAMPLE An NPS 16 (DN 400) Class 1500 reduced-opening ball valve has an allowable minimum bore of 11.30 in. (287.0 mm).



**Table 1—Minimum Bore for Full-opening Valves**

NPS	DN	Minimum <sup>a</sup> Bore by Class, in. (mm) <sup>b</sup>			
		Class 150, 300, and 600	Class 900	Class 1500	Class 2500
½	15	0.50 (12.7)	0.50 (12.7)	0.50 (12.7)	0.50 (12.7)
¾	20	0.75 (19.0)	0.75 (19.0)	0.75 (19.0)	0.75 (19.0)
1	25	0.98 (25.0)	0.98 (25.0)	0.98 (25.0)	0.98 (25.0)
1¼	32	1.25 (31.8)	1.25 (31.8)	1.25 (31.8)	1.25 (31.8)
1½	40	1.50 (38.0)	1.50 (38.0)	1.50 (38.0)	1.50 (38.0)
2	50	1.93 (49.0)	1.93 (49.0)	1.93 (49.0)	1.65 (42.0)
2½	65	2.44 (62.0)	2.44 (62.0)	2.44 (62.0)	2.05 (52.0)
3	80	2.91 (74.0)	2.91 (74.0)	2.91 (74.0)	2.44 (62.0)
4	100	3.94 (100.0)	3.94 (100.0)	3.94 (100.0)	3.42 (87.0)
6	150	5.91 (150.0)	5.91 (150.0)	5.67 (144.0)	5.16 (131.0)
8	200	7.91 (201.0)	7.91 (201.0)	7.55 (192.0)	7.04 (179.0)
10	250	9.92 (252.0)	9.92 (252.0)	9.41 (239.0)	8.78 (223.0)
12	300	11.93 (303.0)	11.93 (303.0)	11.30 (287.0)	10.43 (265.0)
14	350	13.15 (334.0)	12.67 (322.0)	12.40 (315.0)	11.50 (292.0)
16	400	15.16 (385.0)	14.69 (373.0)	14.17 (360.0)	13.11 (333.0)
18	450	17.16 (436.0)	16.65 (423.0)	15.98 (406.0)	14.72 (374.0)
20	500	19.17 (487.0)	18.54 (471.0)	17.87 (454.0)	16.50 (419.0)
22	550	21.18 (538.0)	20.55 (522.0)	19.69 (500.0)	—
24	600	23.19 (589.0)	22.44 (570.0)	21.50 (546.0)	—
26	650	24.92 (633.0)	24.29 (617.0)	23.38 (594.0)	—
28	700	26.93 (684.0)	26.18 (665.0)	25.23 (641.0)	—
30	750	28.94 (735.0)	28.03 (712.0)	27.00 (686.0)	—
32	800	30.66 (779.0)	29.92 (760.0)	28.74 (730.0)	—
34	850	32.68 (830.0)	31.81 (808.0)	30.50 (775.0)	—
36	900	34.41 (874.0)	33.66 (855.0)	32.24 (819.0)	—
38	950	36.42 (925.0)	35.59 (904.0)	—	—
40	1000	38.43 (976.0)	37.63 (955.8)	—	—
42	1050	40.16 (1020.0)	39.61 (1006.0)	—	—
48	1200	45.90 (1166.0)	45.24 (1149.0)	—	—
54	1350	51.65 (1312.0)	—	—	—
56	1400	53.54 (1360.0)	—	—	—
60	1500	57.40 (1458.0)	—	—	—

<sup>a</sup> There is no upper size limit for a valve bore.

<sup>b</sup> The millimeter dimension is the inch dimension multiplied by 25.4 and rounded to one decimal place.

— = no identified minimum bore

**4.4.4 Reduced-opening Valves with Noncircular Opening**

A reduced-opening valve with a noncircular opening that does not conform to 4.4.2 or 4.4.3 shall still satisfy all applicable requirements of this specification. These valves shall include but not be limited to the following:

- axial valves (see Figure B.1);
- check valve axial flow (see Figure B.6);
- check valve, long pattern, typical dual-plate wafer-type (see Figure B.9);

- check valve, piston (see Figure B.10);
- swing check valve, reduced opening (see Figure B.11);
- check valve, short pattern, single-plate wafer-type (see Figure B.12);
- plug valve (see Figure B.15).

NOTE Other valve configurations may apply.

## 4.5 Manufacturing Processes

### 4.5.1 Process Control

The process control activities associated with the manufacturing of a valve identified in Table 2 shall be performed by the manufacturer or outsourced as identified. The manufacturer shall maintain equipment and personnel to achieve conformance to the requirements listed in Table 2 for all activities performed by the manufacturer.

**Table 2—Process Control Requirements**

Item No.	Process Control Activity	Performed by:	
		Manufacturer <sup>1</sup>	Outsourced <sup>2</sup>
1	Product design and validation	X	X
2	Material procurement	X	X
3	Verification of externally provided products or activities	X	Not permitted
4	Machining	X	X
5	In-process inspection	X	X
6	Welding	X	X
7	Assembly	X	Not permitted
8	Factory acceptance testing (Section 10)	X	Not permitted
9	Additional specified requirements per Annexes I, J, K, or L <sup>3</sup>	X	X <sup>3</sup>
10	Marking/tagging/nameplate	X	Not permitted
11	Coating/painting <sup>4</sup>	X	X
12	Corrosion protection and preparation for transport	X	X
13	Final inspection	X	Not permitted
FOOTNOTES <sup>1</sup> See 3.1.21. <sup>2</sup> See 3.1.28. <sup>3</sup> Requirements of L.9, L.10, L.11, and L.12 shall be performed by the manufacturer and shall not be outsourced. <sup>4</sup> See Annex G. X = when performed			

When any process is outsourced in conformance with this specification (see Table 2), the manufacturer shall retain responsibility for all applicable elements of its quality management system and for product conformance to specified requirements.

NOTE For use of outsourced machining services, see API 20M for guidance.

### 4.5.2 Processes Requiring Validation

The manufacturer shall validate the following processes where the resulting output cannot be verified by subsequent monitoring or measurement:

- heat treating (see 6.8 and Annex H);

- welding (see Section 7);
- nondestructive examination, including visual examination (see 7.5.3.2, 7.8, 7.9, 7.10, and Annex I).

## 5 Design

### 5.1 General

#### 5.1.1 Design Standards and Calculations

Design and calculations for pressure-containing parts and pressure-boundary bolting shall conform to an industry-accepted design code or standard such as ASME BPVC, Section VIII, Division 1 or Division 2; ASME B16.34; EN 12516-1; or EN 12516-2; and EN 13445-3.

Allowable stress values used for acceptance shall not exceed those specified by the selected design code or standard.

If the selected design code or standard specifies a test pressure less than 1.5 times the MAWP, the MAWP for the body calculation shall be increased such that the hydrostatic test pressure in 10.3 and I.5 can be applied.

#### 5.1.2 Pressure-containing Parts

Pressure-containing parts shall include bodies, external trunnions, end connectors, bonnets/covers, pipe and flanges used on vent or drain systems, and stems/external shaft.

#### 5.1.3 Pressure-controlling Parts

Pressure-controlling parts shall include the closure member and seat.

The manufacturer shall document engineering practices and acceptance criteria on which the design is based.

The design of the pressure balance hole, when equipped, shall have a ratio between the length of the hole and the hole diameter of less than 10 ( $L/D < 10$ ) up to a maximum hole diameter of 0.5 in. (13 mm).

#### 5.1.4 Bolted Joint Design

Bolting preload torques shall be calculated using an industry-accepted standard, such as API 6A, ASME PCC-1, or EN 1591, with a coefficient of friction on the threads and nut face, based on bolting material, bolting coating, and the type of lubricant applied.

To address variability in bolt stress by torquing, the theoretical bolt stress due to preload shall not exceed 70 % of yield at the allowable temperature.

Where more than one seal of different diameters are used to form the pressure-containing joint, the following requirements apply:

- The gasket or seal diameter used in the bolting calculation and closure flange stress verification shall be the outer seal diameter of the largest seal, or in the case of spiral wound gaskets, the median diameter shall be used.
- Required sealing stress shall be confirmed for all seals and gaskets.
- When verifying the bolt stress at the outer seal diameter of the largest seal, the bolting stress shall not exceed 0.83 of SMYS at test condition (see 10.3).

NOTE A fire-safe seal may be the largest diameter.

## 5.2 Dimensions

### 5.2.1 Standard Face-to-face and End-to-end Dimensions

Standard face-to-face (A) and end-to-end (B and C) dimensions of valves shall conform to the applicable tables in Annex C.

NOTE See Figure B.1 to Figure B.16 for reference to dimension A, dimension B, and dimension C where shown.

Weld end-to-end (B) dimensions of valves shall conform to the applicable tables in Annex C.

Standard face-to-face and end-to-end dimensions for valve sizes not specified in Annex C shall conform to ASME B16.10.

### 5.2.2 Non-standard Face-to-face and End-to-end Dimensions

Non-standard face-to-face and end-to-end dimensions shall conform to K.4.

Non-standard dimensions shall include face-to-face and end-to-end dimensions not shown or not conforming to the values in tables in Annex C or ASME B16.10.

If the non-standard end-to-end dimension includes pipe pups/transition pieces, those pieces shall conform to all requirements for the body.

The length of valves having one weld end and one flanged end shall be determined by adding half the length of a flanged-end valve to half the length of a weld-end valve.

Tolerances on non-standard face-to-face and end-to-end dimensions shall be  $\pm 0.06$  in. ( $\pm 1.5$  mm) for valve sizes smaller than NPS 12 (DN 300), and  $\pm 0.12$  in. ( $\pm 3.0$  mm) for valve sizes NPS 12 (DN 300) and larger.

NOTE Support legs on some valve designs may extend beyond the end-to-end dimensions to assure that the valve can be safely supported.

### 5.2.3 End Connectors

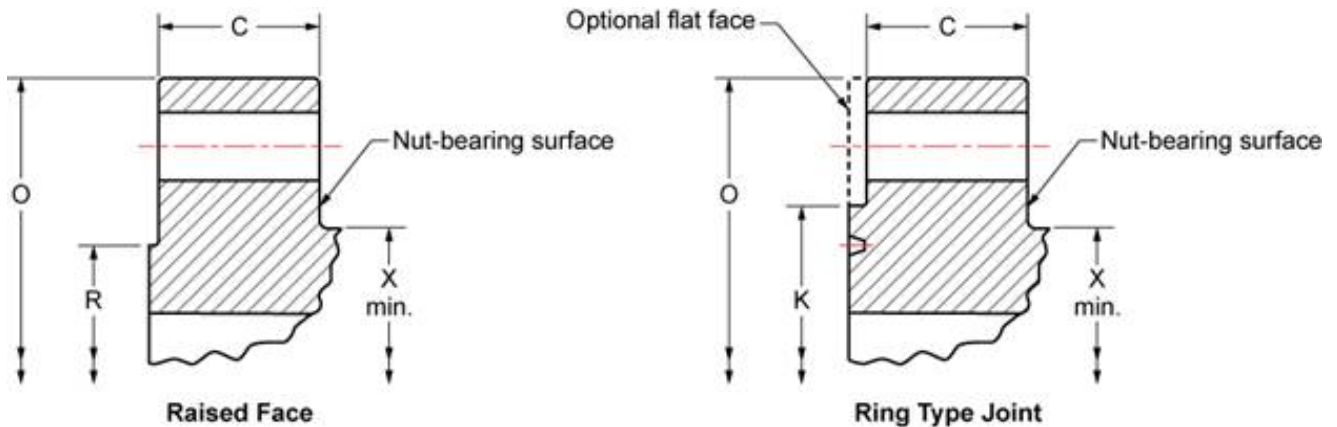
#### 5.2.3.1 Flanged Connectors

##### 5.2.3.1.1 General

Flanges shall be furnished with a raised face or ring joint face (raised face or full face). Specified dimensions, tolerances, and finishes, including drilling templates, flange facing, nut-bearing surfaces (i.e. spot facing and back facing), outside diameters, and thickness (see Figure 1) shall conform to:

- ASME B16.5 for sizes up to and including NPS 24 (DN 600), except NPS 22 (DN 550); or
- MSS SP-44 for NPS 22 (DN 550); or
- ASME B16.47, Series A for NPS 26 (DN 650) and larger sizes; or
- MSS SP-44 for sizes NPS 12 (DN 300) to NPS 60 (DN 1500).

NOTE 1 See K.5 for optional requirements for end connectors.



### Key

C	flange thickness
O	outside diameter of flange
R	raised-face diameter
K	minimum diameter of raised portion of ring type joint flange
X min.	hub diameter

**Figure 1—Typical Flange Dimensions**

Valves with through-bolted flanged end connectors shall be designed to accommodate heavy hex series nuts having dimensions as specified in ASME B18.2.2.

NOTE 2 For valves with heavy wall sections, flanges with nut stops in accordance with Mandatory Appendix 2 of ASME BPVC, Section VIII, Division 1 may apply.

#### 5.2.3.1.2 Lateral Alignment of Flanges

Lateral misalignment (offset) from one flange to the opposite flange shall apply to centerlines of the bores, ring grooves, and bolt circles.

For valves NPS 4 (DN 100) and smaller, lateral misalignment shall not exceed ~~0.079~~0.08 in. (2 mm).

For valves larger than NPS 4 (DN 100), lateral flange misalignment shall not exceed ~~0.118~~0.12 in. (3 mm).

#### 5.2.3.1.3 Parallelism of Flanges

Valves shall be designed to have a maximum parallelism misalignment as follows:

- For valves up to NPS 24 (DN 600) 0.03 in./ft (2.5 mm/m).
- For valves larger than NPS 24 (DN 600) 0.02 in./ft (1.75 mm/m).

#### 5.2.3.1.4 Misalignment of Bolt Holes

For valve end connectors, bolt-hole misalignment of the flange from one end of the valve to the other (see Figure 2) shall conform to the following:

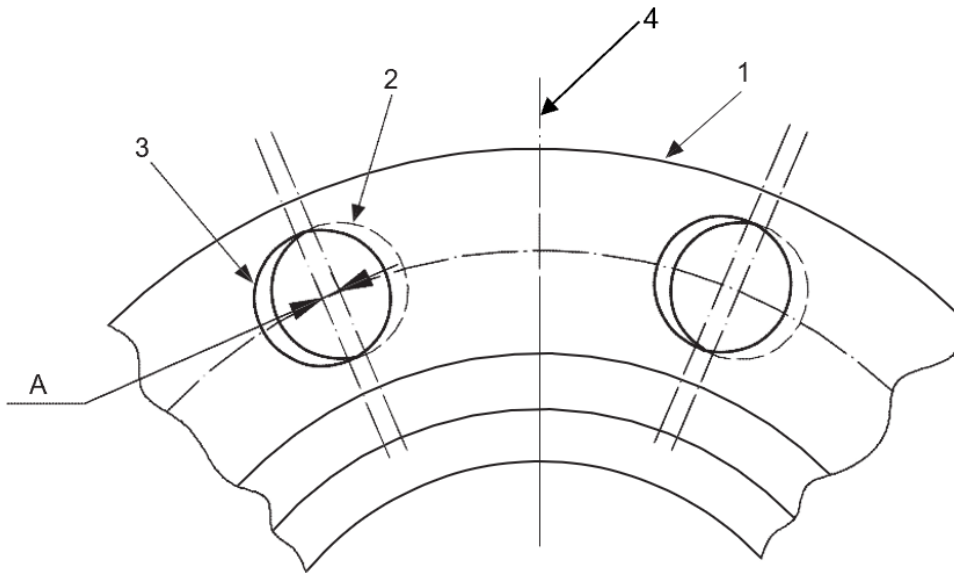
- For valves NPS 4 (DN 100) and smaller, the misalignment shall not exceed 0.08 in. (2 mm) at the bolt holes.

- For valves larger than NPS 4 (DN 100), the misalignment shall not exceed 0.12 in. (3.0 mm) at the bolt holes.

Bolt holes shall be equally positioned on both sides of a reference vertical centerline.

NOTE This reference vertical centerline may not exist in an axial valve.

The nut bearing areas on the flange back face shall be parallel to the flange front face within 1°.



#### Key

- 1 flange
- 2 hole in first flange
- 3 hole in opposite flange for alignment
- 4 valve operator axis (see 5.2.3.1.2)
- A bolt-hole misalignment (see 5.2.3.1.4)

**Figure 2—Bolt-hole Misalignment of Flange Across Valve**

#### 5.2.3.1.5 Studded-end Valve End Connectors

The manufacturer shall notify the purchaser when studded-end connectors are provided on one or more bolt holes. Studded-end connectors shall be provided with threaded holes (studded outlet) for engaging flange bolting.

Threaded-body flange holes for bolts 1 in. or less in diameter shall be threaded in accordance with ASME B1.1, UNC, Class 2B. For bolts 1<sup>1</sup>/<sub>8</sub> in. or larger in diameter, holes shall be threaded in accordance with ASME B1.1, 8-TPI, Class 2B.

NOTE See K.6 for optional requirements for studded-end valve end connectors.

Thread engagement in a flange with threaded holes shall provide full effective thread engagement, not including the chamfered thread, for a length at least equal to the nominal diameter of the bolt thread.

#### 5.2.3.2 Weld end Connectors

Weld-end dimensions shall conform to ASME B31.4, ASME B31.8, or ASME B16.25.

NOTE 1 When the valve body is thicker than the mating pipe, the outside profile may be tapered at 30° and then to 45°, as illustrated in ASME B16.25.

The following details shall be specified for the mating pipe:

- outside diameter;
- length of pup piece;
- wall thickness;
- material grade;
- specified minimum yield strength (SMYS);
- any special chemistry of the mating pipe; and
- if weld overlay has been applied.

NOTE 2 See K.5 for optional requirements for weld-end requirements.

NOTE 3 The pipe pup may be welded and post-weld heat treatment performed, if applicable, prior to valve assembly.

### 5.3 Drive Train

#### 5.3.1 General

The drive train, including the stem, shall be designed such that failure of a part due to an operating condition that exceeds the valve MAST will occur at a point outside the pressure boundary.

The valve design shall prevent the misalignment of the valve stem.

NOTE 1 The weight of the operator and associated drive train components may adversely affect the alignment and deflection of the valve stem.

NOTE 2 Drive train bolting includes bolting used to mount an actuator.

#### 5.3.2 Torque/Thrust

For axial, floating ball, trunnion ball, gate, and plug valves, the design thrust or torque for all drive train calculations shall be at least 2 times the breakaway thrust or torque as defined by 3.1.7.

For swing check valves with extended shafts used for lock open operation, the design torque for all drive train calculations shall be at least 2 times the torque to open the closure member.

For rising stem ball valves, the design thrust or torque for all drive train calculations shall be:

- at least 1.5 times the breakaway thrust or torque associated with the non-preferred sealing side; and
- at least 2 times the breakaway thrust or torque in the preferred sealing side.

NOTE Torque or thrust may be determined by calculation or by measurement.

### 5.3.3 Allowable Stress

Design stresses for tensile stress and shear stress (including torsional shear stress) shall conform to ASME BPVC, Section VIII, except that the design stress intensity value,  $S_m$ , shall be limited to 67 % of yield strength  $S_y$  for the design conditions.

The average primary shear stress across a section loaded at design conditions in pure shear (e.g., keys, shear rings, screw threads, etc.) shall be limited to  $0.6 S_m$ .

The maximum primary shear at design conditions, exclusive of stress concentration at the periphery of a solid circular section in torsion, shall be limited to  $0.8 S_m$ .

Unless otherwise agreed, the design stress intensity limits shall not apply to the components of rolling-element or other proprietary bearings or high-bearing-strength-capable materials that are included in the drive train where manufacturer's recommendations or limits derived from tests and service experience apply. Data and analysis that were the basis for the manufacturer's rating shall be documented.

The average bearing stress shall be limited to the yield strength,  $S_y$ , at design conditions.

NOTE The possibility of a shear failure may exist when bearing loads are applied on parts having free edges, such as at a protruding edge or a keyway.

When mechanical properties at maximum allowable temperature are not available, a yield test shall be performed at maximum allowable temperature, or higher, to document the yield strength at maximum allowable temperature. To establish pressure-temperature ratings, the allowable stress shall be based on the yield strength at ambient temperature and the elevated test temperature.

A joint efficiency factor (strength of weld divided by strength of base material) of 0.75 shall be used for fillet welds.

### 5.3.4 Allowable Deflections

Deflections of the drive train, including extensions when provided, shall not prevent the closure member from reaching the fully closed or fully open position.

NOTE Adherence to the allowable stress limits of design codes alone may not result in a functionally acceptable design.

The manufacturer shall demonstrate, by analysis or test, that under loads resulting from MAWP and any defined pipe or external loads, distortion of the closure member or seat does not impair functionality or sealing.

### 5.3.5 Drive Train Bolting for Quarter-turn Valves

Drive train bolting for quarter-turn valves shall not be subjected to design loads that put the bolt in shear.

## 5.4 Operations

### 5.4.1 Method of Operation

Except for bare stem valves, the method of operation shall be specified.

When a manual gearbox is provided, the output torque/thrust rating shall be at least 1.5 times the maximum required operating torque/thrust of the valve at minimum and maximum allowable temperatures.

NOTE 1 See K.15 for operating temperatures other than the minimum allowable temperature.



The hand-wheel rotary motion of a manual gearbox or wrench (lever) to close a valve shall be clockwise. Rotary motion of anything other than a manual gearbox or wrench (lever) to close a valve shall be per manufacturer specification.

NOTE 2 Valve operational data may be supplied to the purchaser.

NOTE 3 See L.3 for options related to valve operational data.

## **5.4.2 Wrenches (Levers) and Hand-wheels**

### **5.4.2.1 Torque or Thrust**

For axial, ball, gate, and plug valves, the maximum force required at the perimeter of the hand-wheel or wrench (lever) to stroke the valve at the breakaway torque or thrust shall not exceed 80 lbf (360 N) when applied against MAWP.

For check valves, the maximum force required at the perimeter of the hand-wheel or wrench (lever) to stroke the valve at zero differential pressure shall not exceed 80 lbf (360 N).

### **5.4.2.2 Size**

Wrenches (levers) for valves shall either be of an integral design or consist of a head that fits on the stem and is designed to take an extended handle.

Wrenches (levers) that are of an integral design (not loose) shall not be longer than twice the face-to-face or end-to-end dimension of the valve.

Wrenches (levers) longer than 24 in. (600 mm) shall be capable of being removed.

Hand-wheel diameter(s) shall not exceed 40 in. (1 m). Spokes shall not extend beyond the perimeter of the hand-wheel.

## **5.4.3 Position Indicators**

### **5.4.3.1 General**

Unless otherwise specified, valves fitted with an operator shall be furnished with a visible indicator to show the open and the closed position of the closure member.

Position indicators are not required on valves for buried/underground service unless specified by the purchaser.

For plug and ball valves, the wrench and/or the position indicator shall be in line with the pipe when the valve is open and transverse when the valve is closed. The design shall be such that the component(s) of the indicator and/or wrench cannot be assembled to falsely indicate the valve position.

Valves without position stops shall have provision for the verification of open and closed alignment with the operator/actuator removed.

### **5.4.3.2 Position of Closure Member**

Except for check valves, the position of the closure member shall not be altered by dynamic forces of the passing flow, or, in the case of screw-operated gate valves, by forces generated from internal pressure.

#### 5.4.4 Travel Stops

Valves that do not require mechanical force to affect a seal shall be provided with travel stops on the valve and/or operator, and they shall stop the closure member in the open and closed position. The travel stops shall not affect the sealing capability of the valve.

NOTE See Annex D for guidance on travel stops by valve type.

#### 5.4.5 Operators

##### 5.4.5.1 General

Actuators and mounting kits shall conform to API 6DX.

##### 5.4.5.2 Sealing

The interfaces between the operator or enclosed stem extension (when provided) and the valve shall be sealed to prevent the ingress of external contaminants and moisture.

##### 5.4.5.3 Overpressure Protection

Operators and enclosed stem extension assemblies shall be provided with a means of preventing pressure buildup in the mechanism resulting from stem or bonnet seal leakage.

##### 5.4.5.4 Extended Stem and Shaft Assemblies

Extended stem and shaft assembly service shall conform to 5.3.

Extended stems and shaft assemblies shall be protected by an extension casing (housing).

NOTE See L.4 for guidance.

### 5.5 Cavity Relief

The manufacturer shall determine if the valve design could result in liquid being trapped in the body cavity in the open- and/or closed-valve position.

If liquid trapping is possible, the valve shall be provided with automatic cavity relief. For temperatures up to 250 °F (121 °C), the valve cavity relief pressure shall not exceed 33 % differential pressure above the valve pressure rating.

~~For valves in gas or multiphase fluid service at temperatures above 250 °F (121 °C), the manufacturer shall determine the need for cavity relief.~~

~~For temperatures up to 250 °F (121 °C), the valve cavity relief pressure shall not exceed 33 % differential pressure above the valve pressure rating.~~

For valves in gas or multiphase fluid service at temperatures above 250 °F (121 °C), the manufacturer shall determine the need for cavity relief. ~~For temperatures above 250 °F (121 °C), the~~ The valve cavity relief pressure and higher shell design pressure shall be specified by the manufacturer and the hydrostatic shell test shall conform to 10.3.2 or 10.3.3.

For valves NPS 4 (DN 100) and smaller (based on the closure member), external cavity relief valves and the relief valve port shall be NPS 1/4 (DN 8) or larger.

For valves larger than NPS 4 (DN 100) (based on the closure member), external cavity relief valves and the relief valve port shall be NPS 1/2 (DN 15) or larger.

NOTE 1 If a relief valve fitted to the cavity is required, the purchaser may specify provisions to facilitate in-service testing.

NOTE 2 Cavity relief testing and functionality may be demonstrated by tests in I.7.

## 5.6 Body Penetrations

### 5.6.1 Vents and Drains

All double-seated valves that provide a seal against the pressure source with the upstream seat shall be equipped with a drain or vent connector except when specified in conformance with M.3.2.

Vent and drain connectors shall be threaded, welded, studded outlet, or flanged.

If threaded, tapered threads shall be capable of providing a seal and shall conform to ASME B1.20.1.

If parallel threads are used, the connector shall have a head section for trapping and retaining a sealing member suitable for the specified valve service. Parallel threads shall conform to ASME B1.20.1 or ISO 228-1.

The drain size shall conform to Table 3.

**Table 3—Sizes for Drain**

Valve Size		Minimum Pipe Size <sup>1</sup>
NPS	DN	
<2	<50	¼
2 to 8	50 to 200	½
>8	>200	1

<sup>1</sup> The purchaser may specify other sizes and connector types in conformance with K.7.

### 5.6.2 Injection Points

When provided:

- Seat injection points shall have two non-return valves where one of the non-return valves shall be secured in the valve independent of the outer injection fitting.
- Injection fittings shall incorporate a button head connector that is protected by a pressure-containing protective cap/plug. This requirement shall not apply to lubricated plug valves.
- Stem/shaft injection points shall be located above the primary sealing barrier and shall include a fitting inclusive of a non-return valve and a pressure-containing cap/plug.
- Injector fittings of injectable packing points shall include a non-return valve and plunger.
- Injection fittings shall have a MAWP not less than the greater of the MAWP of the valve or the injection pressure.
- Tapered threads shall conform to ASME B1.20.1.
- Parallel threads shall conform to ASME B1.20.1 or ISO 228-1.
- Injection points shall incorporate a non-return valve and a secondary means of isolation for each injection point.

- Protective caps shall:
  - seal off the button head connector by plugging the injection port;
  - allow any entrapped pressure to be released by the provision of a vent hole.

## 5.7 Stem Retention

Valves shall be designed such that the stem is retained by pressure-containing parts and the stem does not eject from internal pressure, under any operating condition or if the packing gland components or valve operator mounting components are removed.

## 5.8 Antistatic

Ball, check, gate, and plug valves shall have electric resistance between the closure member and the valve body and between the stem/shaft and the valve body not exceeding 10 $\Omega$  when measured using a direct current power source not to exceed 12V.

NOTE See L.5 for information on optional testing of electrical resistance.

## 5.9 Lifting

The manufacturer shall determine the need for and verify suitability of lifting points of the valve.

The manufacturer shall develop lifting sketches and handling instructions (see 14.2.1) for safe lifting operations for valves weighing more than 55 lbs (25 kg). The safe working limit (SWL) of each lifting point and the center of gravity of the valve shall be specified in the lifting sketches and handling instructions.

NOTE 1 Regulatory requirements may specify special design, manufacturing, and certification for lifting points.

NOTE 2 For design guidance on lifting lugs, see ASME BTH-1 (service class 0) or API 17D.

NOTE 3 See K.8 for additional information on lifting points.

## 5.10 Design Process

### 5.10.1 General

Designs shall conform to the manufacturer's documented procedures and applicable quality management system requirements.

Design requirements shall include but not be limited to those criteria for size, test and operating pressures, material, environmental, and other pertinent requirements on which the design is based.

### 5.10.2 Design Documentation

Documentation of designs shall include methods, assumptions, calculations, and analysis.

Design documentation media shall be clear, legible, reproducible, and retrievable. Design documentation shall be retained for 10 years after the last unit of that model, size, and rated working pressure is manufactured.

### 5.10.3 Design Review and Verification

The design shall be reviewed and verified by any qualified individual other than the individual who created the original design.

### 5.10.4 Design Validation

Design validation shall be performed in conformance with the manufacturer's validation procedure and the results of design validation shall be documented.

NOTE Annex F provides one method of design validation criteria that may be used for valves provided in the as-shipped condition.

## 6 Materials

### 6.1 Metallic Requirements

#### 6.1.1 General

Metallic pressure-containing and pressure-controlling materials in contact with process fluids shall have documented material specifications that shall define the following:

- material grade;
- chemical analysis;
- heat treatment;
- mechanical properties from tensile test,
- carbon equivalent (CE) under the conditions as specified in 6.3;
- Charpy impacts under the conditions as specified in 6.5,
- hardness under the conditions as specified in 6.6; and
- certification to report all items listed in 6.1.

Metallic pressure-containing parts shall be made of materials consistent with the pressure-temperature rating as determined in conformance with 4.3.

NOTE 1 See API 20A, API 20B, and API 20C for guidance on qualification and production for casting and forging material manufacturers. The use of materials that conform to API 20A, API 20B, and API 20C does not require that the materials be supplied from a facility that has been licensed to API 20A, API 20B, or API 20C.

NOTE 2 See API 20J for guidance on the use of outsourced distributors of metallic material.

#### 6.1.2 Cast Parts

All cast material shall be manufactured using an industry-accepted process.

#### 6.1.3 Forged Parts

All forged material shall be formed using a hot-working practice and heat treatment that produces a wrought (no cast dendritic elements) structure throughout the material.

All forged pressure-containing material shall have a minimum forging reduction ratio of 3:1. The forging ratio shall be included as part of the material certifications.

NOTE See API 20B or API 20C for guidance.

## 6.2 Nonmetallic Requirements

Nonmetallic seals in contact with process fluids shall have documented material specifications that shall define the following:

- generic base polymer, when used (see ASTM D1418);

NOTE 1 Reference to a generic base polymer does not apply to graphite material.

- generic thermoplastic, when used (see ASTM D4000);
- physical property requirements;
- storage requirements.

NOTE 2 For guidance on qualification of polymeric seal manufacturers, see API 20L.

Elastomeric materials for valves in gas service at pressures of Class 600 and above shall be resistant to rapid gas decompression (RGD).

NOTE 3 See L.6 for additional requirements for seals qualification testing.

The manufacturer's documented requirements for nonmetallic seals shall include the following minimum provisions:

- batch number/traceability;
- cure/mold date;
- shelf-life expiration date.

## 6.3 Composition Limits

The chemical composition of carbon steel pressure-containing and pressure-controlling parts shall conform to the applicable material standard.

The chemical composition of carbon steel weld ends shall meet the following requirements:

- The carbon content shall not exceed 0.23 % by mass.
- The sulfur content shall not exceed 0.020 % by mass.
- The phosphorus content shall not exceed 0.025 % by mass.
- The carbon equivalent (CE) shall not exceed 0.43 %.

The CE shall be calculated in conformance with Equation (1):

$$CE = C \% + Mn / 6 \% + (Cr \% + Mo \% + V \%)/5 + (Ni \% + Cu \%)/15 \quad (1)$$

The chemical composition of other carbon steel parts shall conform to the applicable material standard.

The carbon content of austenitic stainless-steel welding ends shall not exceed 0.03 % by mass, except for stabilized material, in which case a carbon content of up to 0.08 % by mass is permissible.

NOTE See K.9 for permissible use of other chemical compositions when specified by the purchaser.

## 6.4 Tensile Test Requirements

Tensile test specimens shall be removed from a test coupon (TC) after the final heat-treatment cycle performed to achieve required mechanical properties.

Pressure-containing and pressure-controlling parts shall have a minimum of one tensile test performed at room temperature in accordance with ASTM A370, ASTM E8, or ISO 6892-1. For metallic materials, the tensile strength, yield strength, and elongation shall be determined.

If the results of the tensile testing do not satisfy the applicable requirements, two additional tests removed from the same TC with no additional heat treatment shall be allowed to qualify the material. The results of both additional tensile tests shall satisfy the applicable requirements.

## 6.5 Impact Test

Carbon, alloy, and stainless steel (except austenitic grades) pressure-containing parts in valves with a specified valve minimum operating temperature below  $-20\text{ }^{\circ}\text{F}$  ( $-29\text{ }^{\circ}\text{C}$ ) shall be impact-tested. The test method shall be the V-notch technique and shall conform to ASTM A370 or ISO 148-1.

When using ISO 148-1, a striker with a radius of 8 mm shall be used.

NOTE 1 Design standards or local requirements may require impact testing for valves with minimum operating temperatures higher than  $-20\text{ }^{\circ}\text{F}$  ( $-29\text{ }^{\circ}\text{C}$ ).

A minimum of one impact test, comprised of a set of three specimens, shall be performed on a representative test bar of each heat of the material in the final heat-treated condition.

Test specimens shall be cut from a separate or attached block taken from the same heat, reduced by forging where applicable, and heat-treated to the same heat treatment, including stress relieving, as the product materials.

NOTE 2 It is not necessary to retest pressure-containing parts stress relieved at or below the previous stress relieving temperature, or  $50\text{ }^{\circ}\text{F}$  ( $28\text{ }^{\circ}\text{C}$ ) below the tempering temperature of the original material.

The impact test shall be performed at or below the lowest temperature as defined in the applicable material specifications or the valve minimum operating temperature, whichever is lowest.

Impact test results for bolting material shall meet the requirements of the applicable material specification.

Impact test results for full-size specimens shall meet the requirements of Table 4 or Table 5.

Test specimen orientation shall conform to the applicable material specification. If the material specification does not define test specimen orientation, either transverse or longitudinal direction shall be acceptable.

**Table 4—Minimum V-notch Impact Requirements for Material other than Duplex and Super Duplex Stainless Steel (Full-size Specimen)**

Specified Minimum Tensile Strength		Average of Three Specimens		Minimum of Single Specimen	
KSI	MPa	Ft-lbs.	Joules	Ft-lbs.	Joules
≤85	≤586	15	20	12	16
>85 to 100	>586 to 689	20	27	16	21
>100	>689	25	34	19	26

**Table 5—Minimum V-notch Impact Requirements for Duplex and Super Duplex Stainless Steel (Full-size Specimen)**

Minimum Test Temperature		Average of Three Specimens		Minimum of Single Specimen	
°F	°C	Ft-lbs.	Joules	Ft-lbs.	Joules
−50	−46	33	45	26	35

If an impact test fails, a retest of three additional specimens removed from the same TC, with no additional heat treatment, may be made, each of which shall exhibit an impact value equal to or exceeding the required average value.

If subsize specimens are used, the Charpy V-notch impact requirements shall be equal to that of the 10 mm x 10 mm specimens multiplied by the adjustment factor listed in Table 6 at the full-size specimen test temperatures.

**Table 6—Adjustment Factors for Subsize Impact Specimens**

Specimen (Dimension)	Adjustment Factor
10 mm x 10 mm (full size)	1 (none)
10 mm x 7.5 mm	0.833
10 mm x 6.7 mm	0.780
10 mm x 5.0 mm	0.667
10 mm x 3.3 mm	0.440
10 mm x 2.5 mm	0.333

## 6.6 Sour Service

Metallic materials for use in sour service shall conform to NACE MR0175/ISO 15156 (parts 1, 2, and 3).

NOTE For guidance on the use of NACE MR0175/ISO 15156 (parts 1, 2, and 3) for bolting, see L.7.

## 6.7 Body Penetrations

Materials for drain, vent, injection components, or other parts shall be compatible with the valve body material or made from a corrosion-resistant material.

## 6.8 Production Heat-treating Equipment

### 6.8.1 General

Heat-treating using batch or continuous type furnaces for pressure-containing parts, pressure-controlling parts, and TCs shall be performed with equipment that is used to process production parts meeting the requirements of this specification. These requirements shall not apply to surface coatings or localized PWHT.

### 6.8.2 Furnace Requirements

#### 6.8.2.1 General

The heat-treatment supplier shall define the temperature range for each operation.

Automatic controlling and recording instruments shall be used.

Thermocouples shall be placed in the furnace working zone(s) and protected from furnace atmospheres by means of suitable protective devices.



### **6.8.2.2 Instrument Accuracy**

The controlling and recording instruments used for the heat-treatment processes shall be accurate to  $\pm 1\%$  of their full-scale range.

**Table 7—Heat Treatment Thermal Uniformity Survey (TUS) Requirements**

Heat Treatment Type	Furnace Classes				
	Class 1 TUS Tolerance ±5°F (±3°C)	Class 2 TUS Tolerance ±10°F (±6°C)	Class 3 TUS Tolerance ±15°F (±8°C)	Class 4 TUS Tolerance ±20°F (±10°C)	Class 5 TUS Tolerance ±25°F (±14°C)
Normalizing	X	X	X	X	X
Annealing	X	X	X	X	X
Solution annealing	X	X	X	X	X
Austenitizing	X	X	X	X	X
Tempering	X	X	X	—	—
Precipitation hardening	X	X	X	—	—
Aging	X	X	X	—	—
Stress relieving	X	X	X	—	—

NOTE The symbol “—” is used to show actions that are not applicable.

**6.8.2.3 Instrument Calibration**

Temperature-controlling and recording instruments shall be calibrated at least once every three months.

**6.8.2.4 Batch-type Furnaces**

Heat treatment of production parts shall be performed with heat-treating equipment that satisfies one of the following:

- calibrated in accordance with 6.8.2.2 and 6.8.2.3 and heat-treat batch-type furnaces that have been surveyed in accordance with Annex H; or
- calibrated and surveyed in accordance with SAE AMS2750 and Table 7.

The temperatures within each batch-type furnace shall be surveyed within one year prior to use of the furnace for heat treatment.

**6.8.2.5 Continuous-type Furnaces**

Heat treatment of production parts shall be performed with continuous-type furnaces that satisfy the following:

- operated, maintained, modified, and repaired in conformance with SAE AMS2750 or SAE AMS-H-6875;
- surveyed in conformance with Annex H.

**6.8.3 Furnace Repairs**

When a furnace is repaired or rebuilt, a new temperature survey shall be carried out before the furnace is used for heat treatment, unless the following conditions apply:

- Repairs return the furnace to the condition it was in at the time of the previous furnace survey and calibration; or
- Repairs do not affect the temperature tolerance of the furnace.

The SAE AMS2750 sections on furnace modifications and furnace repairs shall be used to determine whether a new furnace survey is required. All furnace repairs and modifications shall be documented, and the responsible Quality Assurance organization shall determine whether an additional furnace survey and calibration is required based on the repairs or modifications in conformance with SAE AMS2750 or SAE AMS-H-6875.

#### **6.8.4 Furnace Calibration and Survey Records**

Records of furnace calibration and surveys shall be maintained for a period not less than five years. The minimum records of furnace calibration/survey shall be a certificate of conformance in accordance with Annex H.

## **7 Welding**

### **7.1 General**

HVOF is not a welding process and shall not be required to meet the requirements of Section 7.

### **7.2 Outsourced Welding**

NOTE See API 20G for guidance on the use of outsourced welding services.

### **7.3 Consumables**

The manufacturer shall have a documented procedure for storage and control of welding consumables. Materials of low-hydrogen type (including electrodes, wires, and fluxes) shall be stored and used as recommended by the manufacturer of the welding consumable to retain their original low-hydrogen properties.

### **7.4 Qualification**

Welding, including repair welding, of pressure-containing and pressure-controlling parts shall be performed in accordance with procedures conforming to the requirements of 7.4, 7.5, and 7.6, and qualified to:

- ASME BPVC, Section IX; or
- ISO 15609 (procedures), applicable parts of ISO 15614 (qualification testing).

Welders and welding operators shall be qualified in conformance with ASME BPVC, Section IX, or ISO 9606-1, or ISO 14732.

NOTE The purchaser, pipeline design standards, material specifications, and/or local requirements may specify additional requirements.

The results of all qualification tests shall be documented in a PQR and retained in conformance to the requirements of 14.1.

PWHT shall conform to the material or welding specification or design code.

### **7.5 Weld Overlay**

#### **7.5.1 General**

Qualification of all weld overlay shall conform to ASME BPVC, Section IX or to ISO 15614-7.

Hardness survey requirements shall be applied in conformance with the requirements of NACE MR-0175/ ISO 15156 when the valves are specified for use in sour service.

### 7.5.2 Hard-facing Weld Overlays

Weld overlays for hard-facing shall be applied to thickness and other limitations as detailed in the qualified welding procedure (WPS and PQR).

### 7.5.3 Corrosion-resistant Alloy (CRA) Weld Overlays

#### 7.5.3.1 General

For any CRA weld overlay with nickel-based alloy UNS N06625, the weld metal chemical analysis at the final qualified minimum cladding thickness identified on the procedure qualification shall be iron dilution class Fe 10: iron mass fraction 10.0 % maximum, unless the purchaser specifies otherwise (see K.10).

The iron dilution achieved at the finished minimum qualified thickness shall be identified on the weld procedure qualification records.

For all other compositions of weld overlay, the chemical analysis of the weld metal shall conform to the manufacturer's documented specification at the minimum qualified thickness.

#### 7.5.3.2 NDE in the Final Supplied Condition

CRA weld overlays in the final supplied condition shall be visually inspected in conformance with ASME BPVC, Section V, Article 9. The following acceptance criteria shall apply:

- The undercut shall not reduce the thickness in the area (considering both sides) to below the minimum thickness.
- Surface porosity and exposed slag shall not be permitted on or within 1.77 in. (45 mm) of sealing surfaces.

Surface NDE shall be performed on the weld overlay in the final supplied condition using penetrant testing in conformance with ASME BPVC, Section V, Article 6. Acceptance shall conform to ASME BPVC, Section VIII, Division 1, Appendix 8.

## 7.6 Impact Testing

Qualifications of procedures for welding of pressure-containing parts and for repair welding shall conform to 7.4.

Impact testing shall be performed on carbon, alloy, and stainless steel (except austenitic grades) for the qualification of procedures for welding on valves with an allowable temperature below  $-20^{\circ}\text{F}$  ( $-29^{\circ}\text{C}$ ).

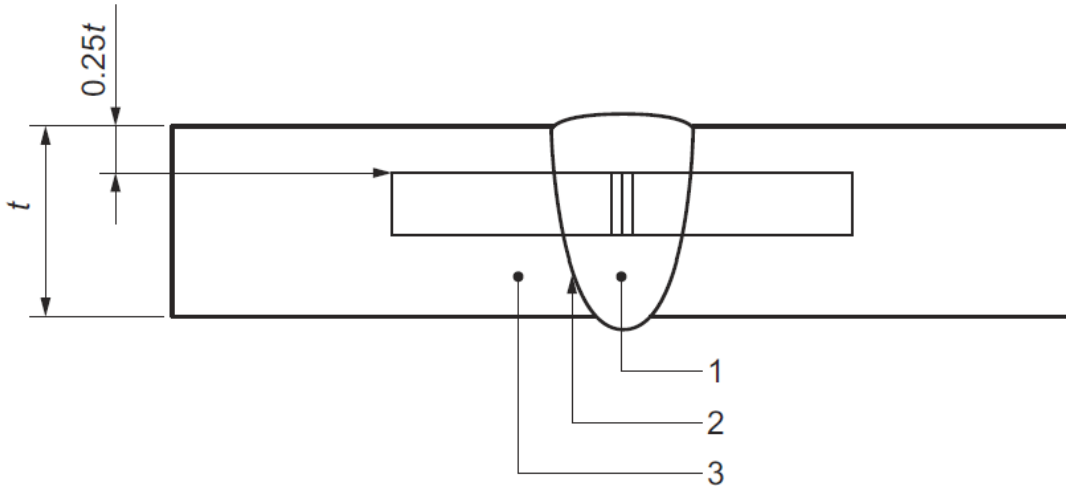
NOTE Design standards and/or local requirements may require impact testing at minimum allowable temperatures above  $-20^{\circ}\text{F}$  ( $-29^{\circ}\text{C}$ ).

Impact test results for full-size specimens shall meet the requirements of Table 4 or Table 5. When subsized specimens are used, the Charpy V-notch impact requirements shall be equal to that of the 10 mm x 10 mm specimens multiplied by the adjustment factor listed in Table 6 at the full-size specimen test temperatures.

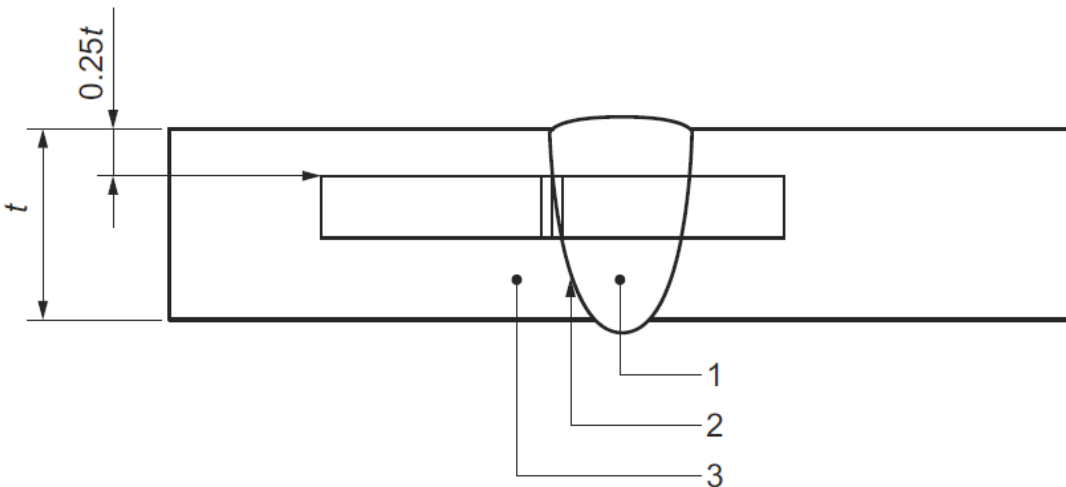
At a minimum, one set of three weld metal (WM) impact specimens shall be taken from the WM at the location shown in Figure 3. The specimens shall be oriented with the notch perpendicular to the surface of the material.

Multiple sets of weld metal impact specimens shall be required when more than one welding process is used. Weld metal impact testing shall be performed to represent each welding process being qualified.

A set of three impact specimens shall be taken from the heat-affected zone (HAZ) at the location shown in Figure 4. The notch shall be placed perpendicular to the material surface at a location resulting in a maximum amount of HAZ material located in the resulting fracture.

**Key**

- 1 weld metal (WM)
- 2 heat-affected zone (HAZ)
- 3 base metal (BM)

**Figure 3—Charpy V-notch Weld Metal Specimen Location****Key**

- 1 weld metal (WM)
- 2 heat-affected zone (HAZ)
- 3 base metal (BM)

**Figure 4—Charpy V-notch Heat-affected Zone Specimen Location**

The HAZ tests shall be conducted for each of the materials being joined when the base materials being joined are of a different P-number and/or group number that conforms to ASME BPVC, Section IX or ISO/TR 15608 when one or both of the base materials being joined are not listed in the P-number and/or group number.

Impact testing shall conform to ASTM A370 or ISO 148-1 using the Charpy V-notch technique. Impact specimens shall be etched to determine the location of the weld and HAZ.

When using ISO 148-1, a striker with a radius of 8 mm shall be used.

The impact test temperature for welds and HAZs shall be at or below the minimum allowable temperature specified for the valve. Impact test results for full-size specimens shall meet the requirements of 6.5. If the material specification requires higher impact values than those shown in 6.5, the higher values shall apply.

### 7.7 Hardness Testing

Hardness testing shall be carried out as part of the welding procedure qualification on pressure-containing and pressure-controlling parts in valves required to meet NACE MR0175 or ISO 15156 (all parts).

Hardness surveys shall be performed on base metal (BM), weld metal (WM), and heat-affected zone (HAZ) in conformance with the requirements of NACE MR0175 or ISO 15156 (all parts).

### 7.8 Visual Inspection—Welds to Pressure-containing Parts

Welds to pressure-containing parts shall be visually inspected in conformance with ASME BPVC, Section V, Article 9. The following acceptance criteria shall apply:

- The undercut shall not reduce the thickness in the area (considering both sides) to below the minimum thickness.
- Surface porosity and exposed slag shall not be permitted on or within 1.77 in. (45 mm) of sealing surfaces.

### 7.9 Visual Inspection—Pressure-containing and Pipe Pup Welds

Pressure-containing welds and pipe pup-to-valve welds shall be visually inspected in conformance with ASME BPVC, Section V, Article 9. The following acceptance criteria shall apply:

- The undercut shall not reduce the thickness in the area (considering both sides) to below the minimum thickness.
- Surface porosity and exposed slag shall not be permitted on or within 1.77 in. (45 mm) of sealing surfaces.

### 7.10 NDE of Welds Joining Pipe Pups to the Valve

For all pressure-containing pipe pup-to-valve welds, surface NDE shall be performed using at least one of the following methods:

- Magnetic particle testing on weld bevels of weld ends after machining, prior to welding, and of the final weldment shall conform to ASME BPVC, Section V, Article 7, and acceptance shall conform to ASME BPVC, Section VIII, Division 1, Appendix 6.
- Penetrant testing on weld bevels of weld ends after machining, prior to welding, and of the final weldment shall conform to ASME BPVC, Section V, Article 6, and acceptance shall conform to ASME BPVC, Section VIII, Division 1, Appendix 8.

For all pressure-containing pipe pup-to-valve welds, volumetric NDE examination shall be performed using at least one of the following methods:

- Radiographic testing on 100 % of the welds in accordance with ASME BPVC, Section V, Article 2, and acceptance shall conform to ASME BPVC, Section VIII, Division 1, UW-51 for linear indications and ASME BPVC, Section VIII, Division 1, Appendix 4, for rounded indications.
- Ultrasonic testing on 100 % of the welds in accordance with ASME BPVC, Section V, Article 4, and acceptance shall conform to ASME BPVC, Section VIII, Division 1, Appendix 12.

NOTE See L.8 for additional requirements for NDE for weld end connectors.

## 7.11 Manufacturing Repair

### 7.11.1 Casting Repair at the Material Supplier

The manufacturer's documented material specification for castings shall specify the limitations for welding repair at the casting material supplier as follows:

- Requirements for qualified weld procedures and qualified welders in conformance with ASTM A488/A488M, ASME BPVC Section IX or ISO 15607, ISO 15609, ISO 15614-1 and ISO 15614-7, or equivalent.
- Requirement to perform new mechanical testing in conformance with the original material specification, in case the PWHT temperature is less than 50 °F (28°C) below the final tempering temperature of the original material.
- Requirement to perform new mechanical testing in conformance with the original material specification if the PWHT is a solution anneal.

NOTE Per API 20A, repair welding is defect removal resulting in a wall thickness below an acceptable value as specified in purchasing documents.

### 7.11.2 Casting Repair at the Manufacturer

Repair of defects shall be performed in conformance with a documented procedure specifying requirements for defect removal, welding, heat treatment, nondestructive examination (NDE), and reporting.

Removal of surface defects shall not compromise the minimum wall thickness and shall provide a smooth transition between the ground area and the original contour. After surface defect removal, the excavated area shall be examined by either:

- magnetic-particle (MT) inspection in accordance with ASME BPVC, Section V, Article 7, and acceptance criteria shall conform to ASME BPVC, Section VIII, Division 1, Appendix 7; or
- liquid-penetrant (PT) examination in accordance with ASME BPVC, Section V, Article 6, and acceptance criteria shall conform to ASME BPVC, Section VIII, Division 1, Appendix 7.

After completion, repair welds on pressure-containing parts shall be examined using MT or PT, as well as the same NDE method that was used to identify the defect when another method was used. If visual inspection was used to identify a defect, inspection by MT or PT alone shall be acceptable. Method and acceptance criteria shall be as specified in 7.11.2. The final NDE activities shall be conducted after any required post-weld heat treatment.

Repair weld of castings shall be performed in conformance with the applicable material standard, including any PWHT when required.

When the PWHT temperature is less than 50 °F (28 °C) below the final tempering temperature of the original material, new mechanical testing shall be performed in conformance with the original material specification.

When the PWHT is a solution anneal, new mechanical testing shall be performed in conformance with the original material specification.

### 7.11.3 Forgings and Plate

Weld repair on forgings and plates shall be limited to being performed to only correct machining errors.

Unless otherwise agreed, weld repair of forgings and plates shall not be performed to correct material defects (see K.11).

#### **7.11.4 Repair of Welds**

Repair of welds shall be performed in accordance with the applicable design code or standard listed in 5.1, including any PWHT where applicable.

## **8 Bolting**

### **8.1 Pressure-boundary Bolting**

Pressure boundary bolting shall conform to:

- API 20E, BSL-1 for alloy and carbon steel bolting or API 20F, BSL-2 for corrosion-resistant bolting if the specified bolting materials are listed in API 20E or API 20F; or
- the manufacturer's documented material specification and design code listed in 5.1 if the specified bolting materials are not listed in API 20E or API 20F.

NOTE 1 Use of bolting that conforms to API 20E and API 20F does not require that the bolting be supplied from a facility that has been licensed to API 20E or API 20F.

NOTE 2 Use of bolting that conforms to API 20E and API 20F includes identification of the bolts in accordance with the specified marking requirements.

NOTE 3 See API 21TR1 for guidance on the selection of bolting materials.

Low-temperature carbon and alloy steel bolting shall conform to ASTM A320/A320M for the specific grade of material.

### **8.2 Other Bolting**

All bolting that does not satisfy the requirements of 8.1 shall conform to accepted industry specifications or the manufacturer's documented material specification.

## **9 Quality Control**

### **9.1 Measuring and Test Equipment Control**

#### **9.1.1 Control**

Equipment used to inspect, test, or examine valves or valve parts shall be identified, controlled, calibrated, and adjusted at specified intervals in accordance with documented manufacturer instructions, and consistent with nationally or industry-accepted standards specified by the manufacturer, to maintain the accuracy required by this specification.

### **9.2 Pressure-measuring Device**

#### **9.2.1 Type and Accuracy**

A test pressure-measuring device (analog or electronic) shall be accurate to at least  $\pm 2.0$  % of full scale. If an analog pressure gauge is used in lieu of a pressure transducer, it shall be selected such that the test pressure is indicated within 20 % and 80 % of the full-scale value.



The requirement of 9.2 shall not apply to a pressure-recording device unless the device is used for both measurement and recording.

### **9.2.2 Calibration Procedure**

A pressure-measuring device shall be calibrated with a master pressure-measuring device or deadweight tester to at least three points, which shall be equidistant across the full scale of the device. The full scale end points (zero and 100 %) are not required calibration points; however, if included in the calibration, the scale end points shall be in addition to the required points used for calibration.

### **9.2.3 Calibration Intervals**

Calibration intervals shall be established by the manufacturer for calibrations based on repeatability and degree of usage.

The initial interval between calibrations shall be a maximum of 90 days until recorded calibration history can be established by the manufacturer. Increases to the interval between calibrations shall be limited to 90-day increments, with a maximum calibration interval between calibrations to not exceed 1 year.

Calibration intervals shall be adjusted based on review of the recorded calibration history, and determination of interval adjustments shall be defined in the manufacturer's documented procedure.

The calibration interval shall start on the date of first use, not to exceed three months from the date of calibration. The date of first use shall be recorded. If the calibration interval is not started within three months of the date of calibration, the equipment shall be identified as out of calibration.

## **9.3 Welding Inspectors**

Personnel performing visual inspections of welding operations and completed welds shall be qualified and recorded in conformance with the manufacturer's documented procedures.

## **9.4 Visual Inspection**

### **9.4.1 Visual Examination Personnel**

Personnel performing visual inspection for acceptance shall pass an annual vision examination in conformance with the manufacturer's documented procedures that satisfy the requirements of ASNT SNT- TC-1A or ISO 9712.

### **9.4.2 Visual Inspection of Castings**

At a minimum, visual inspection of all pressure-containing and pressure-controlling steel castings shall conform to MSS SP-55. The following acceptance criteria shall apply:

- Type I: none acceptable;
- Type II to XII: Category A and B only.

For cast materials not covered by MSS SP-55, visual inspection and acceptance criteria shall conform to the manufacturer's documented procedures.

### **9.4.3 Visual Inspection of Forgings**

At a minimum, visual inspection of all pressure-containing and pressure-controlling steel forgings shall conform to ASME BPVC Section VIII, Division 1, UF-45, and UF-46. Acceptance criteria shall be that no visible defects, including seams, laps, and folds, shall be accepted.

#### 9.4.4 Visual Inspection of Finished Machined Parts

In addition to the requirements of 9.4.2 and 9.4.3, the machined areas of pressure-containing and pressure-controlling castings and forgings shall be visually inspected in conformance with the manufacturer's requirements.

For seals, gaskets, seat springs, and parts with plating, the parts shall be visually inspected in conformance with the applicable industry material specification.

#### 9.5 Storage for Nonmetallic Seals

The manufacturer's written requirements for nonmetallic seals that are not assembled into equipment shall include the following information at a minimum:

- age control;
- indoor storage;
- maximum temperature not to exceed 120 °F (49 °C);
- protected from direct natural light;
- stored unstressed (see NOTE below);
- stored away from contact with liquids;
- protected from ozone and radiographic damage.

Packaging and storage of elastomeric seals shall not impose tensile or compressive stresses sufficient to cause permanent deformation or other damage.

NOTE Recommendations are typically available from seal manufacturers. Where applicable, for a given seal design, rings of large inside diameter and relatively small cross-section may be formed into three equal superimposed loops to avoid creasing or twisting, but it is not possible to achieve this condition by forming just two loops.

#### 9.6 Valve Assembly

Valves shall be assembled per documented procedures developed by the manufacturer. The procedure shall include bolt tightening requirements for pressure-boundary bolting.

Interfaces between pressure-controlling parts shall be assembled free of any sealant, except where the sealant is the primary means of sealing.

When lubricant is used for the assembly of pressure-controlling parts, the lubricant shall not exceed the viscosity range of SAE 10W motor oil or equivalent.

NOTE 1 Other parts, such as threads, bearings, sliding parts, etc., may be lubricated for assembly using an appropriate oil or grease.

NOTE 2 See K.12 for guidance on restriction of assembly lubricant.

## 10 Factory Acceptance Testing

### 10.1 Pressure Testing—General

#### 10.1.1 Procedure

Documented test procedures that identify test methodology, test durations, and acceptance criteria shall be developed and maintained for all pressure testing performed in conformance to this specification.

The equipment used to perform the required pressure tests shall not apply external forces that affect seat or body seal leakage. If an end-clamping fixture is used, the valve manufacturer shall demonstrate that the test fixture does not affect the seat or body joint sealing capability of the valve being tested.

Each valve shall be tested in the fully assembled condition to the manufacturer's procedures prior to shipment.

NOTE 1 See K.13 for testing one-piece bodies in non-assembled condition.

Pressure testing shall be performed before external coating of the valve.

If the valve has been previously pressure tested to the requirements of this specification, subsequent repeat hydrostatic and gas testing may be performed without removal of the valve external coating.

Testing shall be performed in the following order based on the applicable valve configuration:

a) stem backseat (10.2);

NOTE 2 Per the requirements of 10.2, the backseat test may be performed either immediately before or immediately after the hydrostatic shell test in 10.3.

b) hydrostatic shell (see 10.3):

- standard (10.3.1);
- higher (10.3.2);
- with external relief (10.3.3);
- with pipe pups (10.3.4);
- with drain, vent, and sealant injection lines (10.3.5);

c) hydrostatic seat (see 10.4):

- standard (10.4.1);
- check valves (10.4.2);
- axial on-off, ball, gate, and plug valves (10.4.3).

#### 10.1.2 Test Conditions

The hydrostatic test fluid shall be water and shall contain a corrosion inhibitor. The chloride content of test water in contact with austenitic and duplex stainless-steel wetted components of valves shall not exceed 30 µg/g (30 ppm by mass). The chloride content in the test water shall be tested at least every 12 months and records shall be maintained in conformance with the documentation requirements of Section 14.

NOTE The hydrostatic test fluid may have antifreeze (glycol) added at the discretion of the manufacturer.

Valves shall be tested with the seating and sealing surfaces free from sealant except where the sealant is the primary means of sealing. A secondary seat and/or stem packing sealant injection system, if provided, shall not be used before or during testing.

All hydrostatic and gas shell tests specified shall be:

- performed with the valve unseated and partially open; or
- performed with the valve fully open, provided the body cavity is simultaneously filled and pressurized through a cavity connection.

The supply pressure shall be isolated from the valve during hydrostatic/gas shell testing and shall be stabilized prior to the start of pressure testing duration. The stabilization criteria shall be documented in the manufacturer's pressure testing procedure.

The pressure-measuring device shall be installed in the test apparatus in such a manner that the device indicates the test pressure of the valve assembly. The minimum test pressures shall be maintained for the duration of the test and shall be held for the minimum test durations as specified in 10.2, 10.3, or 10.4.

### 10.1.3 Leakage

For hydrostatic or gas testing, visible leakage (see 3.1.54) shall be any release of test fluid observed during the pressure test duration. Test fluid released during the seat test pressure build-up or pressure bleed-down shall not be recognized as visible leakage. Visible leakage shall be observed directly, including through a window or by video equipment.

If video equipment is used, resolution and brightness shall be sufficient to detect leakage.

## 10.2 Stem Backseat Test

Testing of the backseat shall be performed on valves that have this feature and shall commence with the packing gland loose unless a test port is provided. Self-energized packing or seals shall be removed unless a test port is provided for this test.

The valves shall be filled with the ends closed off and the closure member in the partially open position until leakage of the test fluid around the stem or through the test port is observed. The backseat shall then be closed and a minimum pressure of 1.1 times the pressure rating determined in conformance with 4.3 for material at 100 °F (38 °C) based on the valve end connector material. The test duration shall conform to Table 8 based on the valve end connector size.

**Table 8—Minimum Duration of Stem Backseat Tests**

Valve Size		Test Duration <sup>a</sup> (minutes)
NPS	DN	
≤ 4	≤ 100	2
≥ 6	≥ 150	5

<sup>a</sup> Test duration starts once the valve is stabilized per manufacturer's procedures.

**Warning—Due to the possibility of ejection of the stem from the valve body under high pressure, safety precautions must be taken.**

Monitoring for leakage shall be through a test access port or by monitoring leakage around the loosened packing.

There shall be no visible leakage permitted during the backseat stem test.

## 10.3 Hydrostatic Shell Test

### 10.3.1 Hydrostatic Shell Test Preparation, Method, and Acceptance Criteria

Valve ends shall be blocked and the closure member placed in any position according to 10.1.2.

When present, relief valves that release to the atmosphere shall be removed and their connection points plugged. Injection ports that are equipped with an internal non-return valve shall be tested without the injection fitting installed.

The test pressure for the hydrostatic shell test shall be a minimum of 1.5 times the pressure rating conforming to 4.3 for material at 100 °F (38 °C) based on the valve end connector material. The test duration shall conform to Table 9 based on the valve end connector size.

**Table 9—Minimum Duration of Hydrostatic Shell Tests**

Valve Size		Test Duration <sup>a</sup> (minutes)
NPS	DN	
≤ 4	≤ 100	2
6 to 10	150 to 250	5
12 to 18	300 to 450	15
20 and larger	500 and larger	30

<sup>a</sup> Test duration starts once the valve is stabilized per manufacturer's procedures.

There shall be no visible leakage permitted during the hydrostatic shell test.

NOTE See Annex J for additional guidance on extended shell tests.

### 10.3.2 Higher Hydrostatic Shell Test

When the valve has been designed to withstand a higher shell pressure per 5.5, the shell test pressure shall not be less than 1.5 times the pressure specified in 5.5.

When performing a higher shell test and the valve is flanged, the hydrostatic shell test shall be performed with bore sealing plugs that prevent the flanges from being subjected to test pressures greater than 1.5 times the valve flange rating.

The test duration specified in Table 9 shall start after stabilization.

NOTE Some material groups may require higher shell pressures in accordance with 5.5 to meet both the "1.5 times" shell test requirement at 100 °F (38 °C) and the 33 % cavity relief requirement if required.

### 10.3.3 Hydrostatic Shell Test with External Relief Valves

After hydrostatic shell testing, external relief valves shall be fitted to valves that have this feature. The connection to the valve body shall be tested at 95 % of the set pressure of the relief valve for 2 minutes for valve sizes up to and including NPS 4 (DN 100) and 5 minutes for valve sizes NPS 6 (DN 150) and larger. The relief-valve connection shall be free of visible leakage during this period.

The external relief valves shall be set to relieve at the specified pressure in accordance with 5.5.

### 10.3.4 Hydrostatic Shell Test with Pipe Pups

A hydrostatic shell test shall be required if pipe pups are to be welded to the valve as part of the final valve assembly by the manufacturer. Test pressure, duration, and acceptance criteria shall conform to 10.3.1.

When the allowable test pressure rating of the pipe pup is less than the required hydrostatic test pressure, the valve shall first be hydrostatic tested without the pipe pups welded to the valve. Subsequently, the pipe pups shall be welded to the valve followed by a hydrostatic shell test of the assembly at a lower pressure than the MAWP specified by agreement.

The test duration specified in Table 9 shall start after stabilization.

There shall be no visible leakage permitted during the hydrostatic shell test with pipe pups.

### 10.3.5 Hydrostatic Test of Drain, Vent, and Sealant Injection Extension Lines

If provided as part of the final assembly, drain, vent, and sealant injection lines shall be subject to a hydrostatic test with the valve.

If testing with the fully assembled valve is not practicable, these lines shall be tested separately at the test pressure in 10.3.1. All extension pipe connected to the valve assembly shall be subjected to a hydrostatic pressure test in conformance with 10.3.1. Pressure boundary fittings such as pipe plugs or blind flanges that replace test fixtures/fittings are not required to be subjected to pressure testing.

## 10.4 Hydrostatic Seat Test

### 10.4.1 Hydrostatic Seat Test Preparation, Method, and Acceptance Criteria

Lubricants or sealants shall be removed from seats and closure member sealing surfaces except where the lubricant or sealant is the primary means of sealing or if the lubricant complies with the viscosity requirements of 9.6.

NOTE See K.14 for guidance on performing alternate seat testing.

The test pressure for all seat tests shall be a minimum of 1.1 times the pressure rating conforming to 4.3 for material at 100 °F (38 °C) based on the valve end connector material. The test duration shall be based on the end connector size of the valve and shall conform to Table 10.

Seat test acceptance criteria shall be based on the bore diameter of the closure member.

Seat test duration and acceptance criteria for noncircular opening valves shall be based on the NPS of the valve end connector size.

**Table 10—Minimum Duration of Hydrostatic Seat Tests**

Valve Size		Test Duration <sup>a</sup> (minutes)
NPS	DN	
≤ 4	≤ 100	2
6 to 18	150 to 450	5
20 and larger	500 and larger	10

<sup>a</sup> Test duration starts once the valve is stabilized per manufacturer's procedures.

Seat leakage shall be monitored from the downstream side of the seat when under hydrostatic seat test.

The acceptance criteria for leakage shall be as follows:

- For soft-seated valves and lubricated plug valves: Leakage shall not exceed ISO 5208, Rate A (no visible leakage for the duration of the test at test pressure).
- For metal-seated valves, other than check valves: Leakage shall not exceed ISO 5208, Rate C.

NOTE The test procedures for various types of block valve are specified in 10.4.3.

— For metal-seated check valves: Leakage shall not exceed ISO 5208, Rate G.

On completion of hydrostatic seat testing, parts such as drain plugs, injection fittings, and cavity-relief valves shall be fitted in conformance with the manufacturer's documented procedures.

#### **10.4.2 Hydrostatic Seat Test—Check Valves**

The hydrostatic seat test pressure for check valves shall be applied from the downstream direction of the required flow blockage.

#### **10.4.3 Hydrostatic Seat Test—Axial On-Off, Ball, Gate, and Plug Valves**

##### **10.4.3.1 Unidirectional Valve**

For axial on-off, ball, gate, and plug valves, with the valve half-open, the valve and its cavity shall be entirely filled with test fluid. The valve shall then be closed, and the test pressure applied to the appropriate end of the valve. Leakage shall be monitored at the downstream side of the tested seat, i.e., via the valve body cavity in case of an upstream seated valve or via the downstream side of the valve in case of a downstream seated valve.

##### **10.4.3.2 Bidirectional Valve**

For axial on-off, ball, gate, and plug valves, with the valve half-open, the valve and its cavity shall be entirely filled with test fluid. The valve shall then be closed, and the test pressure applied sequentially to both ends of the valve. Leakage shall be monitored at the downstream side of the tested seat, i.e., via the valve body cavity in case of an upstream seated valve or via the downstream side of the valve in case of a downstream seated valve.

#### **10.4.4 Additional Seat Testing**

If the purchaser specifies the functionality for the valve to be that of double block and bleed (DBB) valves, the test described in L.9 shall be performed.

If the purchaser specifies the functionality for the valve to be that of double isolation and bleed with both seats bidirectional (DIB-1), the test described in L.10 shall be performed.

If the purchaser specifies the functionality for the valve to be that of double isolation and bleed with one seat unidirectional and one seat bidirectional (DIB-2), the test described in L.11 shall be performed.

If the purchaser specifies a DIB-1 or DIB-2 operational performance verification, the test described in L.12 shall be performed.

The testing specified in L.9, L.10, L.11, and L.12 shall be performed by the manufacturer and shall not be outsourced.

### **10.5 Hydrostatic Test—Cavity Relief Valve**

If provided, the cavity relief valve (to the atmosphere) shall have the pressure set, tested, and certified to relieve to atmospheric pressure at the pressure specified by the relief-valve supplier or by the valve manufacturer.

The set pressure of relief valves shall be between 1.1 and 1.33 times the valve pressure rating conforming to 4.3 for material at 250 °F (121 °C). The reseal pressure shall not be less than 1.05 times the valve pressure rating conforming to 4.3 for material at 250 °F (121 °C). The manufacturer shall specify the set pressure of relief valves for temperatures above 250 °F (121 °C).

## 11 Coating/Painting

All non-corrosion-resistant valves shall be coated or painted externally in conformance with the manufacturer's documented requirements.

NOTE 1 See Section 13 on corrosion protection for details.

NOTE 2 See L.13 for requirements for coating of corrosion-resistant valves.

**CAUTION—When external coating or painting operations are performed, preventative measures must be taken such that no foreign material enters the internal cavity of the valve that can impact the valve function.**

Flange faces, actuator or gearbox mounting flange sealing surfaces, and weld bevel ends shall not be coated.

Coating shall conform to Annex G for both flange and weld end connectors.

## 12 Marking

### 12.1 General

Valve body marking shall conform to the requirements of Table 11 and 12.4. Check valves shall be marked with an arrow indicating the direction of flow.



Table 11—Valve Marking on Body

Item No.	Marking	Section	Format Example	
1	Manufacturer's name <sup>a, c</sup>	— <sup>e</sup>	Per manufacturer requirements	
2	Unique serial number <sup>b</sup>	14.1	Per manufacturer requirements	
3	ASME Pressure Class Rating <sup>b</sup> or Intermediate Pressure Rating <sup>b</sup>	4.3.1	150, 300, 600, 900, 1500, or 2500	
		4.3.2	PN155, 2250 psi	
4	Body/end-connector material designation <sup>b, f, g, j</sup>	6	Material grade	
5	Body/end-connector melt identification <sup>f, g</sup>	— <sup>e</sup>	Cast or heat number	
6a	Nominal valve size <sup>b, d</sup>	Full-opening valves: nominal valve size	4.4.2	8 or DN 200
6b		Reduced-opening valves with circular opening: <sup>d</sup>	4.4.3	8 x 6 or DN 200 x 150 or 8R x bore or DN 200R x bore
6c		Reduced-opening valves with noncircular opening	4.4.4	8R (DN200R)
7	SMYS (units) of valve ends <sup>h</sup>	5.1	SMYS 40 KSI or SMYS 276 MPa	
8	Ring joint groove number <sup>i</sup>	— <sup>e</sup>	R49	
9	Flow direction (for check valves only)	12.1	Flow <sup>k</sup> → or ← Flow <sup>k</sup>	

FOOTNOTES

<sup>a</sup> Shall be on *either* the body or the nameplate at a minimum; may be on both.

<sup>b</sup> Shall be on *both* the body and the nameplate.

<sup>c</sup> Additional use of trademark/brand names with the manufacturer's name is optional.

<sup>d</sup> Bore may be marked in in. or (mm).

<sup>e</sup> No specific document reference identified.

<sup>f</sup> When the body is manufactured from more than one type of material, all materials of the body and end-connector shall be identified—MSS SP-25 gives guidance on marking.

<sup>g</sup> Body includes body/end connector.

<sup>h</sup> On body weld ends only.

<sup>i</sup> On flange OD for flanged connectors conforming to 5.2.3.1.1.

<sup>j</sup> Where the grade and class does not uniquely identify the material specification, the material specification, grade, and class shall be marked. Example: A516-70 or A537 CL2.

<sup>k</sup> The word "flow" is optional.

Additional marking shall conform to Table 12.

Body, end connector, and cover/bonnet marking shall be:

- a low-stress die-stamped (rounded "V" or dot face type); and/or
- laser engraved; and/or
- cast.

The marking on the body, end connector, and bonnet/cover shall be visually legible prior to painting/coating the valve. The marking on the nameplate shall be visually legible.

For valves NPS 2 (DN 50) and larger, the marking on the body, end connector, and bonnet/cover shall be 0.25 in. (6 mm) or greater in height.

**Table 12—Additional Marking**

Item No.	Marking	Format	Location
1	Bonnet/cover material designation <sup>a</sup> (see Section 6)	Material grade	On bonnet/cover
2	Bonnet/cover melt identification (cast or heat number)	A516-70/12345	On bonnet/cover
3	Seat sealing direction (for valves with preferred direction)	(see Figure 5)	On separate identification plate affixed to valve body, bonnet/cover, or end connector
4	Safe working limit (SWL) of lifting points	Per manufacturer requirements	Per manufacturer requirements

<sup>a</sup> Where the grade and class does not uniquely identify the material specification, the material specification, grade, and class shall be marked. Example: A516-70 or A537 CL2, etc.

## 12.2 Valve Size Marking

Except for reduced-opening valves, valve sizes shall be marked with the nominal pipe size (NPS) or nominal diameter (DN).

When there are no minimum bore dimensions listed for a valve pressure class and size stated in Table 1, the size and bore shall be by agreement and the manufacturer shall stamp/mark the size and bore on the nameplate.

Reduced-opening valves with a circular opening shall be marked with the nominal size of the end connectors and the nominal size of the reduced opening in conformance with Table 1, or marked with the nominal size followed by “R” and the actual bore.

**EXAMPLE 1** An NPS 16 (DN 400) Class 150 valve with a reduced 11.93 in. (303 mm) diameter circular opening shall be specified as NPS 16 (DN 400) x NPS 12 (DN 300).

**EXAMPLE 2** An NPS 16 (DN 400) Class 150 valve with an actual bore 14.75 in. (375 mm) diameter circular opening shall be specified as NPS 16R (DN 400R) x 14.75 in (375 mm).

Reduced-opening valves with a noncircular opening and other valves per 4.4.4 shall be marked with the nominal size in conformance with Table 1 corresponding to the end connectors, followed by the letter “R”.

**EXAMPLE 3** A reduced-bore valve with an NPS 16 (DN 400) end connector and a 15 in. x 12 in. (381 mm x 305 mm) rectangular opening shall be specified as 16R.

## 12.3 Nameplate

Valve nameplate marking shall conform to the requirements of Table 13.

Each valve shall be provided with an austenitic stainless-steel nameplate securely affixed and so located that it is accessible.

The nameplate for valves larger than NPS 4 (DN 100) shall be securely affixed to the valve body; however, based on valve design, the nameplate may be attached to the bonnet/cover or end connector at the option of the manufacturer.

The maximum allowable working pressure at the minimum and maximum temperatures, including restrictions of temperature (such as limitations imposed by nonmetallic parts), shall be marked on the nameplate.

For valves NPS 4 (DN 100) and smaller, the nameplate shall be securely affixed to the valve body or attached to the valve with braided corrosion-resistant wire.

The nameplate minimum letter size shall be 0.125 in (3 mm) on valve sizes NPS 2 (DN 50) and larger.

For valves less than NPS 2 (DN 50), the nameplate letter size shall be per the manufacturer's standard.

For non-standard valves, the nominal size and face-to-face or end-to-end dimensions shall be stated on the nameplate; see 5.2.2.

The manufacturer's name, including country, shall be as defined in 3.1.21.

**Table 13—Valve Marking on Nameplate**

Item No.	Marking	Section	Format Example	
1	Manufacturer's name <sup>a, c</sup>	— <sup>e</sup>	Per manufacturer requirements	
2	Specification	— <sup>e</sup>	"6D" or "API 6D"	
3	Unique serial number <sup>b</sup>	14.1	Per manufacturer requirements	
4	Date of manufacture	— <sup>e</sup>	MM-YY (e.g. 05-18 is for May 2018)	
5	Manufacturer country	12.3	NL; Made in Italy; Made in U.K.	
6	ASME Pressure Class Rating <sup>b</sup> or Non-standard valve pressure rating <sup>b</sup>	4.3.1	150, 300, 600, 900, 1500 or 2500	
		4.3.2	PN155, 2250 psi	
7	Pressure–temperature rating: a) maximum allowable working pressure at maximum temperature and b) maximum allowable working pressure at minimum temperature	4.3	1480 psi at 250 °F; 10.2 MPa or 102 bar at 121 °C  1500 psi at –20 °F; 10.4 MPa or 104 bar at –29 °C	
8	Face-to-face/end-to-end dimensions, if not shown in or does not conform to Table C.1 to Table C.6	5.2	11.26 in. or 286 mm	
9	Body/end connector material designation <sup>a, f</sup>	6.1	Material grade	
10	Trim identification <sup>g</sup> : material grade symbols indicating metallic materials for stem, sealing faces of closure members, non-metallic seat to closure member seal materials	6.1	Stem 13Cr; Disc 13Cr; Seat 13Cr/PEEK; Seals FKM	
11a	Nominal valve size <sup>b</sup>	Full-opening valves: nominal valve size	4.4.2	8 or DN 200
11b		Reduced-opening valves <sup>d</sup>	4.4.3	8 x 6 or DN 200 x150 or 8R x bore or DN 200R x bore
11c		Non-standard opening valves	4.4.4	8R (DN200R)
12	Supplemental double block or isolation tests (if applicable)	L.9, L.10, or L.11	DBB, DIB-1, or DIB-2	
13	QSL, when specified	Annex I	QSL2, QSL3, QSL3G, QSL4, or QSL4G	
14	SLH, when specified	Annex M	SLH1, SLH2, SLH3, or SLH4	

**FOOTNOTES**

<sup>a</sup> Shall be on *either* the body or the nameplate, at a minimum; may be on both.

<sup>b</sup> Shall be on *both* the body and the nameplate.

<sup>c</sup> Additional use of trademark/brand names with the manufacturer's name is optional.

<sup>d</sup> Bore may be marked in in. or (mm).

<sup>e</sup> No specific document reference identified.

<sup>f</sup> When the body is manufactured from more than one type of material, all materials of the body and end connector shall be identified.

<sup>g</sup> MSS SP-25 gives guidance on marking.

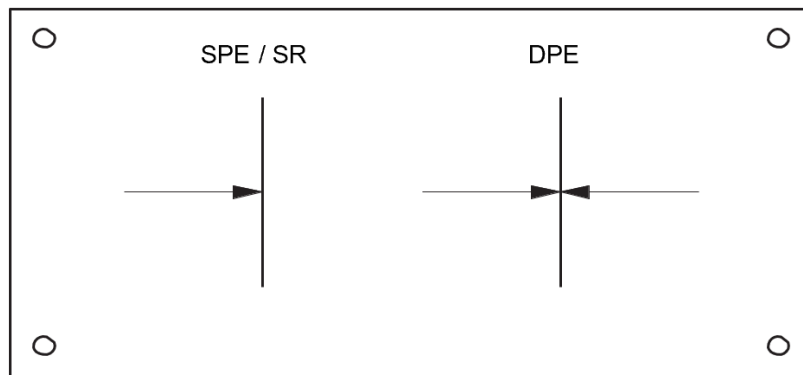
## 12.4 Supplemental Requirements

Omission of the body markings shall be permitted when the valve size or shape limits the application of all required marking. Allowable marking omissions shall be one of the following:

- marking of the size;
- marking of the size and class rating.

For valves with one unidirectional seat and one bidirectional seat, the directions of both seats shall be specified on a separate identification plate, as illustrated in Figure 5.

Each flange/weld end connector shall be marked/stamped with “SPE / SR” on the side that contains a single piston effect seat and with “DPE” on the side that contains a double piston effect seat.



**Figure 5—Typical Identification Plate for a Valve with One Seat Unidirectional and One Seat Bidirectional**

NOTE In Figure 5, one symbol indicates the bidirectional seat and the other symbol indicates the unidirectional seat.

## 13 Draining, Protection, and Preparation for Transport

### 13.1 Draining

Upon completion of all factory acceptance testing, valves shall be drained of test fluids, dried, and lubricated in conformance with the manufacturer's documented requirements before shipment.

### 13.2 Protection

The manufacturer shall have documented procedures to address the following:

- a) corrosion protection using the manufacturer's documented requirements on bare metallic machined surfaces, such as flange faces, weld bevel ends, exposed stems, and internal surfaces of the equipment;
- b) corrosion protection applied to exposed metallic surfaces of steels with less than 15 % chromium on flange faces, weld bevel ends, exposed stems, and all accessible internal surfaces of the equipment;
- c) corrosion protection provided by a corrosion inhibitor having a runoff temperature of minimum 200 °F (93 °C)

NOTE Applying corrosion inhibitor on a stem and not removing it prior to operating the valve can damage stem seals.

- d) valve end connector shall be covered or plugged to protect the sealing surfaces, threads, weld-end, and valve internals from damage;
- e) cover/plug shall be securely affixed to the valve;
- f) the design of the covers/plugs shall prevent the valves from being installed unless the covers/plugs have been removed.

### 13.3 Preparation for Transport

The manufacturer shall have documented procedures to address the following additional requirements:

- a) closure member position for transport;
- b) storage.

## 14 Documentation

### 14.1 Minimum Documentation and Retention

The documentation identified in the following list shall be maintained by the manufacturer for a minimum of 10 years following the date of manufacture (see 3.1.12):

- design documentation;
- weld procedure specification (WPS);
- weld procedure qualification record (PQR);
- NDE records;
- visual inspection records;
- chloride content in the hydrostatic test water (see 10.1.3);
- valve assembly serial number traceable to the following information:
  - 1) material test report for body, bonnet/cover, stem and end connector, and additional related requirements of Annex I;
  - 2) pressure test results (including hydrostatic and or gas) and additional related requirements of Annex I;
  - 3) for sour service valves, certificate of conformance to NACE MR0175/ ISO 15156.

NOTE Purchaser or regulatory requirements can specify additional records or a longer record retention period.

The documentation shall be maintained by the manufacturer in legible, retrievable, and reproducible form and free of damage.

### 14.2 Documentation Provided with the Valve

#### 14.2.1 General

The documentation identified in the following list shall be provided to the valve purchaser:

- in the installation, operation, and maintenance instructions, any valve orientation that is not permitted or that may impede valve performance;
- lifting sketches and safe handling instructions (see 5.9) for valves weighing greater than 55 lbs (25 kg);
- notification of a pressure balance hole in the closure member when present.

#### **14.2.2 Certificate of Conformance**

The manufacturer shall supply a certificate of conformance to this specification.

The certificate shall identify the following:

- 1) valve type (axial, ball, check, gate, or plug);
- 2) size;
- 3) pressure class;
- 4) end connector(s);
- 5) serial number(s);
- 6) additional requirements when specified by the manufacturer or purchaser in Annex F, Annex I, Annex J, Annex K, Annex L, and Annex M;
- 7) a statement that the valve is in conformance with this product specification edition and addenda on the date of manufacture;
- 8) design code for pressure-containing parts and pressure-boundary bolting (see 5.1.1);
- 9) code used for pressure-temperature rating (see 4.3).

## Annex A (informative)

### Repair or Remanufacture of Valves

#### A.1 Requirements

This annex defines the requirements for repair or remanufacture of valves originally manufactured in accordance with this specification, which shall be applied when specified by the manufacturer or purchaser.

The requirements of this specification that address design, materials, quality control, welding, NDE, pressure testing, marking, and records shall apply.

This annex shall not be applicable to:

- valves damaged by fire;
- field repair (with or without the replacement of parts) and modification of equipment;
- surplus equipment intended for resale.

The definitions of remanufacturer (see 3.1.38) and repairer (see 3.1.39) shall only apply to this annex.

Remanufacture is performing disassembly, reassembly, and testing of a valve with or without replacement of parts and can include machining, welding, heat-treating, and/or other manufacturing operations and shall not include replacement of the body.

Repair shall not include machining, welding, heat-treating, other manufacturing operations, or replacement of bodies.

**WARNING—Valves may contain pressurized fluid and/or residual hazardous fluid, and/or stored energy. Operating the valve can lead to the release of product, potentially under pressure.**

NOTE Additional requirements may apply by agreement.

#### A.2 Preparation of Valves for Shipment to the Repairer/Remanufacturer

##### A.2.1 General

The valve owner/operator is responsible for delivering the complete valve assembly to the repairer/remanufacturer in accordance with A.2.2 or A.2.3.

##### A.2.2 Valves Not Requiring Failure Investigation and Analysis

The repairer/remanufacturer shall verify that the following activities have been performed:

- pressure removed from the valve cavities and accompanying actuators, tanks, etc.;
- valves cleaned of produced fluids and tested for naturally occurring radioactive material (NORM) in accordance with regulations applicable in shipping and receiving locations. Material safety data sheets (MSDS) for any preservation fluids, lubricants, or hydraulic fluids shall be shipped with the valves. Records of the cleaning shall be available on request;

- flanged and weld ends blanked off to protect the gasket face, weld ends, and valve internals during shipment;
- block valves to be stroked to drain the cavities and left in the full open condition for shipment;
- seized or non-operational valves are tagged accordingly, and the cavity drained or vented as far as practicable by other means, e.g., body vents.
- if removal of the actuator is necessary, its installed orientation documented;
- hydraulic and pneumatic actuators shipped in a depressurized and de-energized condition;

NOTE For valves that are inoperable, seized, or jammed, special procedures may be required for the safe removal of the actuator.

- check valves shipped with the disc supported or secured during transit;
- lifting equipment on the valve including lifting lugs, brackets, tapped holes for lifting brackets are subjected to a visual inspection prior to handling to identify damaged components;
- valves inspected for damage;
- record operation problems, functionality defects, and reason for valve repair, if known.

### **A.2.3 Valves Requiring Failure Investigation and Analysis**

In addition to A.2.2, the repairer/remanufacturer shall verify that the following activities have been performed:

- issuing a statement from the owner/operator that the valve has remained untouched when removed from service, other than removing pressure and draining process fluids;
- installed location and orientation is to be clearly marked on the valve (e.g., plant/platform side and pipeline side, downstream and upstream, DPE and SPE seats);
- care taken to ensure evidence is not tampered with or otherwise negatively impacted while cleaning the valve;
- photos of the valve, required as follows:
  - 1) before removal from the line, and include installation positioning including actuation device, auxiliary piping, and instrumentation;
  - 2) as removed (internal and external) before any cleaning;
  - 3) as prepared for shipment.

## **A.3 Receiving Activities**

### **A.3.1 Receiving Activities for Valves Not Requiring Failure Investigation and Analysis**

The valve shall be traceable to the owner. Each valve shall be assigned a unique identifier (see A.4.1.2).

A preliminary visual inspection shall be conducted per Table A.1. The owner shall be notified if the valve cannot be remanufactured or repaired. All actions to be completed per Table A.1 shall be documented.



**Table A.1—Initial Inspection**

Item	Action to be Completed
<b>Initial Inspection</b>	
Nameplate(s) and all body marks, stamps	— Review all markings, and identify any markings that could indicate a previously remanufactured or repaired valve.
External condition	— stains or other signs of leakage from main body or body joints; — paint or coating condition for damage; — general staining on body, which would clearly indicate the valve; — location/orientation; — coating on bolts/nuts; — evidence of previous repair; — bolting corrosion; — body fittings for corrosion; — signs of gearbox/actuator moving on body.
<b>Marking</b>	
Match-mark all components	— Allow for reassembly in identical orientation. — Tag each fitting.
<b>Valve Operability (If applicable)</b>	
Gearbox/lever valves Operate valve	Look for: — any movement of the flange joints; — any grittiness in operation; — excessive backlash or freedom of movement; — evidence of sand and debris in the valve; — surface of the exposed part of the sealing member as the valve is moved and photograph; — excessive force required to operate the valve.

**A.3.2 Receiving Activities for Valves Requiring Failure Investigation and Analysis**

In addition to A.3.1, the repairer/remanufacturer shall verify that the following additional activities have been completed.

- Photograph the valve as identified in Table A.2, at a minimum.
- Confirm if witness inspection or pre-disassembly pressure test is required.

**Table A.2—Items for Photographic Inspection**

Items
1) general side views, both sides 2) end view, both ends 3) bolting especially if bolting shows signs of damage 4) all fittings 5) cracks in paint or coating near or at joints. 6) nameplates and other body markings 7) any damage or other areas of concern 8) actuator/gearbox/lever position 9) stem position with gearbox/actuator removed—If provided, document the position of the key.
NOTE Table A.2 may be used as a template for completing the activities in A.3.2.

## **A.4 Disassembly and Cleaning of Valves**

### **A.4.1 Disassembly and Cleaning Activities—Failure Investigation/Analysis Not Required**

#### **A.4.1.1 Disassembly and Cleaning**

Valves to be remanufactured/repared shall be completely disassembled. During disassembly, visual condition of the body, end connector, trim components, bolting, and other components shall be recorded to establish the scope of remanufacture/repair.

Packing, gaskets, and nonmetallic parts shall be removed and disposed of in accordance with the owner's instructions and the remanufacturer's/repairer's procedures.

NOTE 1 Valves may contain packing, sheet gaskets, and spiral wound gaskets that may contain hazardous material that may require special disposal processes.

Valve parts shall be cleaned. Finished surfaces that may be damaged during cleaning shall be protected.

NOTE 2 Valves that may undergo simple repair (e.g., seal replacement) do not need to have paint or coating removed prior to pressure test.

#### **A.4.1.2 Identifier/Traceability**

The original equipment manufacturer (OEM) nameplate/tags/serial number shall not be removed.

Nameplates/tags from previous repair or remanufacture activities shall be removed. The removed tag shall be retained or scanned/photographed and retained in the document files. A new identifier number shall be applied.

NOTE 1 The identifier may be a serial number as discussed in Section 12.

Finished surfaces that may be damaged shall be protected. Identification numbers marked on parts shall remain on the parts throughout the remanufacturing or repairing process.

NOTE 2 Smaller parts may be placed in a container labeled with the unique identification number.

Joints and matching parts shall be match-marked, stamped, or doweled such that the valve can be re-assembled in the same arrangement and condition as delivered.

Marking/labeling shall be of a type and material that resists damage, fading, or loss, consistent with the expected storage duration.

### **A.4.2 Disassembly and Cleaning Activities—Failure Investigation/Analysis Required**

In addition to the requirements of A.4.1, valves requiring failure investigation and analysis shall be disassembled and evaluated to capture additional evidence applicable to the investigation.

Elastomeric seals shall be protected from further degradation and stored if needed for investigation.

Table A.3 shall be used for completing the activities for ball valves and can be used as a guide for other valve types. When used for other valve types, the repairer/remanufacturer shall include additional items applicable to the valve type. All actions to be completed shall be documented.

**Table A.3—Disassembly of Ball Valve with Seat Leakage**

Item	Action to be Completed
<b>Follow OEM's sequence of dismantling</b>	
Body fittings	Remove and check for corrosion in ports, bad threads, blocked ports.
<b>WARNING—Pressure may exist under fitting</b>	
Injectors	Remove and check for grease in ports; take a sample.
Gearbox/lever	Remove and check if the valve is on open stop.
Stem	Measure side-to-side movement in two directions, with hand pressure on stem; record the values.
Cap screws	Remove and secure the adapter plate using a torque wrench; record the torque.
Dowels	Remove and check for any clearance.
Bonnet and body	Match-mark bonnet with body, and stem key orientation is noted/photographed.
Stem and bonnet	Remove using the hole in the stem as a lift point; if there is no hole in the stem, secure the stem to the bonnet before removing the bonnet to prevent the stem from falling out of the bonnet.
Stem bore	Check for debris, sand, and any foreign material.
Bonnet seals (before removal)	Check for damage to the bonnet seal and, if present, the anti-extrusion ring.
Bonnet seals (after removal from bonnet)	Check for extrusion, explosive decompression, damage to anti-extrusion rings, nibbing, seal hardness, and compression set (flat sides). Photograph in situ and when removed. If extruded, note the position of the extrusion.
Stem bore	Inspect the condition of the bore for body distortion.
Stem	Repeat measurement of side-to-side movement; record movement.
Remove the stem from the bonnet and inspect all parts	Check for: <ul style="list-style-type: none"> <li>— extrusion of seals, damage to bearings, damage to anti-extrusion rings, function of anti-static components;</li> <li>— stem surface finish/plating breakdown;</li> <li>— damage to keyways.</li> </ul>
Ball	Replace the stem drive on the ball; look for any backlash/movement.
<b>Turn the valve bore vertical, with leaking side of the valve on the upper side, if identified</b>	
Body bolts	Record the location of any loose bolting. If torque values are required, all coating shall be removed prior to measuring the torque.
<b>Ensure all removed components are match-marked during disassembly. The first removed end connector and corresponding side of the body will be match-marked as Side A</b>	
Adapter and seat rings assembly	Remove studs and nuts (may be removed with the adapter).
Bolting	Remove one at a time, check for straightness and for any bolt bending in a specific quadrant of the valve.
O-ring seals on adapter with seals still in place	Check any swelling or seal coming out of the groove (see "bonnet seals" row above), photograph.
Seals	Remove and inspect (see "bonnet seals" row above); photograph.

Item	Action to be Completed
Seats	Difference side-to-side and/or springs supporting seat ring not pushing the seat ring hard up onto the securing screws. Can be indicator to seat stuck in seat pocket.
	Measure any gap between the seat retaining screws and seat (both sides). If no screws are present, measure height of seat above adapter in 4 places with 90 degrees between each measurement.
Surface of seat	Check for grease.
Sealing surface of seat	Check for gaps/breaks and scuffs, sand impregnation, splaying. For fluorocarbon and nitrile seating valves, identify where any gaps are, and refer to location of the vent holes in the seat Identify orientation versus valve position in service: bottom, top break open point, reseal point.
Seat area	Photograph.
Seat ring	Mark for orientation relative to the top/bottom trunnion.
Seat securing screws	Remove.
Seat ring assembly	Remove and check for any tightness or jamming.
O-ring in place	Inspect O-ring (see "bonnet seals" row above).
O-ring removed	Inspect O-ring (see "bonnet seals" row above). If damaged by extrusion, note the flow direction of the extrusion.
End of bearing plates and dowels	Inspect; corrosion can indicate that the bearing plates have not been in hard contact with the adapter.
Bearing plates, ball location	Mark with reference.
Bearing plates and ball	Remove.
Ball	Mark for side A/B (clockwise to close from above).
Ball sealing line in closed.	Inspect for misalignment. Determine if under-travel or over-travel is present.
Ball sealing area	Check for damage and scrapes—particularly in the lower part of the valve—indicative of damage by debris.
Body	Remove. Once removed, match-mark all components to the corresponding seat and end connector side. The other (second) side of the valve is marked with Side B.

## A.5 Evaluation of Components

### A.5.1 Minimum Requirements for Evaluation and Repair/Remanufacturer of Parts

Components involved in the valve repair/remanufacture shall be inspected and evaluated (visual and dimensional inspection) in accordance with documented procedures (see Table A.4 as a template).

**Table A.4—Requirements for Evaluation of Components**

Inspection	Acceptance	When Acceptance Not Satisfied—Repair Guidance
<b>Surfaces including Weldments and Screw Threads</b>		
Visible surfaces	No damage or deterioration of parts.	Report to the purchaser for action; repair to be agreed.
Wear Surfaces	Inspect for disbondment of coating, plating, cladding, or other surface treatment.	Replace.
Cracks and linear types of defects, including forging laps	Minimum wall thickness shall be maintained.	Removal of surface defects is permitted. If the wall thickness is less than the required minimum, no repair/remanufacture permitted.
Corrosion/erosion visual	Per repairer/remanufacturer or purchaser requirements. For valves in compliance with ASME B16.34 wall thickness, the dimensions shall not be less than those found in ASME B16.34, Table 3-A or 3-B. No local material loss greater than 0.078 in. (2 mm).	Weld repair permitted.
Sealing areas	<ul style="list-style-type: none"> <li>— No visible damage.</li> <li>— No corrosion pits.</li> <li>— Surface finish for O-rings per repairer/remanufacturer or purchaser requirements (see ISO 3601-2 for guidance).</li> </ul>	Repair by replace component, welding and/or machining.  When a corrosion resistant overlay is used as part of the repair, it shall not be considered as part of the valve wall thickness.
Flanged ends	See 5.2.3	Skim face if thickness of flange and face-to-face dimensions will remain in tolerance. Otherwise perform weld repair and re-machine.
Hub ends  NOTE Some hub designs use special materials to meet the pressure temperature ratings. Select weld procedures accordingly.	Per repairer/remanufacturer, purchaser requirements, or OEM.	Skim face if thickness of hub and face-to-face dimensions will remain in tolerance. Otherwise perform weld repair and re-machine.
Tapped/threaded holes that have been repaired by a wire-insert thread repair kit shall be subjected to a pull-out test using a tensioner or similar.	No chipped, damaged, pulled threads or sheared off studs. Check with go/no-go gauge.	Re-cut threads, drill, and re-tap any broken studs. NOTE Wire-insert thread repair may be used subject to agreement by purchaser.
Tapped NPT fittings	Go/no-go gauge plus visual inspection.	Drill deeper, with counterbore, or weld repair and re-cut, or machine oversize.

Inspection	Acceptance	When Acceptance Not Satisfied—Repair Guidance
Casting linear defects, porosity, surface breaking defects NOTE Through wall defects resulting in leakage require re-heat treatment after weld repair. If the valve distorts during heat treatment, it can become unusable.	See 9.4.2	Excavate, and if still greater than minimum wall thickness, grind smooth and perform surface inspection.  If less than minimum wall thickness, weld repair, followed by surface inspection.
Forging laps and other defects	See 9.4.3	Excavate, and if still greater than minimum wall thickness, grind smooth and perform surface inspection.  If less than minimum wall thickness, approval to leave as-is or repair by welding shall be subject to agreement by the purchaser.
Other machined areas	Geometry retains the original design intent by OEM.	Machine the part, and/or weld repair.
Dimensional checks for ovality in body bore and stem bore, particularly 3-piece ball valves	Check for circularity in both stem bore and body bore per purchaser requirements. NOTE Some ovality can be acceptable if a) the valve is behaving elastically, and b) the seal extrusion gaps are not compromised.	Report results of ovality to purchaser.  No further work unless otherwise agreed.
<b>Stem/Shaft</b>		
Straightness	Check for operational restrictions. NOTE A general guideline is 0.001 in./in. (0.001 mm/mm) of length.	Replace.
Surface finish in sealing area	Per repairer/remanufacturer or purchaser requirements.	For valves with adjustable packing, the diameter may be reduced by agreement with the purchaser.  For non-adjustable packing, the stem shall be replaced.
Check for twist quarter-turn valves.	Check keyway for signs of deformation.	Replace the stem and keys.
Inspect thread profile in rising stem valves.	Inspect drive nut for fit and form. Inspect thread profile with a gauge.	Clean up thread or replace.
Tee nut/stem drive.	Inspect for fit and form.	Replace the worn part.
Tee nut connection to stem.	If pinned connection, check condition.	Replace the pin and/or oversize.
Keyway	No excessive clearance, no side burrs, and no out-of-straightness on the keyway.	Replace the stem and keys.
Thrust bearing area	No burrs or wear on surface finish.	Reestablish the surface finish.
Stem diameter in sealing area	Clearances and profile in conformance with OEM data.	Replace.

Inspection	Acceptance	When Acceptance Not Satisfied—Repair Guidance
Plating/coatings	No flaking, scratches, or other damage.	Remove plating and re-apply to original dimensions.
<b>Scratches, Scores, or Other Damage to Surfaces of the Ball</b>		
General	Surface visual inspection.	Re-grind the ball. NOTE Typical nominal reduction is 0.001 in. per in. (0.001 mm per mm) of ball spherical diameter, with a maximum of 0.040 in. (1 mm). Otherwise, weld repair or replace.
Plating damage	Surface visual inspection.	Remove plating. Replace plating.
Trunnion damage	Surface visual inspection.	Weld repair or replace. No under-sizing permitted.
Tungsten carbide coating (TCC)	Surface visual inspection, plus PT. No indications in sealing area.	Remove coating TCC. Ball dimensions may be reduced by 0.001 in per in. (0.001 mm per mm) of ball spherical diameter, with a maximum of 0.04 in. (1 mm) Re-coat. No reduction in thickness permitted on parallel type gate valves.
Hard weld deposit/facing	Surface visual inspection plus PT.	Repair method to be agreed between repairer/remanufacturer and purchaser.
<b>Inserts and Seat Ring</b>		
Soft insert	Surface inspection for impregnation of solids, digs, scuffs.	Skimming of insert and seat ring to maintain original profile. No more than 0.005 in. (0.12 mm) shall be removed. Otherwise, new seats or, depending on design/material, reinsert the soft insert.
Tungsten carbide coating (TCC)	Surface visual inspection, plus PT. No indications in sealing area.	Remove TCC. Re-establish original geometry.
Hard weld deposit/facing	Surface visual inspection plus PT.	Repair method to be agreed.
General inspection	No splits, stretch, swelling, nipping, nibbling, extrusion, bubbles, discoloration, compression set. (See ISO 3601-3 for guidance on geometry).	Replace.
General inspection.	All studs to be removed from tapped holes and inspected.	Replace bolts/studs that are damaged or not able to be removed without damage.
Straightness.	Any bending determined by either rolling on a flat table or with a straight edge.	Replace.
<b>Bolting</b>		
Thread profile	Check by running nut down full length. No burrs, thread pulls, rounding, or necking.	Replace per Section 8.
Under head cracking.	Inspect under head of bolts and cap screws by PT/MT. No indications permitted.	Replace per Section 8.

Inspection	Acceptance	When Acceptance Not Satisfied—Repair Guidance
Thread tolerance	Per repairer/remanufacturer or purchaser requirements. See 5.1.1 and 5.1.4. ASME B1.1. Class 1A.	Replace per Section 8.
Marking	Check for manufacturer's mark and/or material grade stamped on ends and/or head, e.g., ASTM A962/A962M	If no marking, replace. See A.5.7.
Head	Any damage to the external hex, 12-point head, or internal hex that could compromise the safe and reliable application of the load.	Replace per Section 8.
<b>Drains and Plugs</b>		
Drain cocks/threaded plugs	Removed and checked for functionality, sealing, damage, threads with go/no gauges.	Replace.
Sealant injection ports/fittings	Removed and checked for functionality, sealing, damage, threads with go/no gauges. In addition, pressure tested to the hydrotest pressure of the valve body prior to re-assembly.	Replace.

### A.5.2 Bodies, Bonnets, End Connectors, End Pieces, Tailpieces, and Covers

Bodies, bonnets, end connectors, end pieces, tailpieces, and covers shall be visually inspected.

NOTE NDE may be employed to investigate the extent of visual defects.

Defects such as cracks, wear, cuts, scoring, or excessive metal loss shall be brought to the attention of the owner for disposition instructions.

All tapped holes shall be visually inspected for missing or incomplete threads, defective thread profile, torn or ruptured surfaces, and cracks. Defects shall be removed/repared.

Flanged end dimensions shall conform to the applicable specification per 5.2.3.1.1.

Face-to-face and end-to-end dimensions shall conform to 5.2.1 or to dimensions specified by the purchaser (see 5.2.2).

Stem seal preparations or stuffing boxes shall be verified to meet the dimensional, material, and surface finish requirements that were validated for the seal design. Surface corrosion shall be removed by polishing, machining, or other suitable means. Dimensions and finishes of the repaired/remanufactured surface shall be inspected and documented.

### A.5.3 Stems

The parts shall be free of burrs or other mechanical damage that can affect the strength, function, or fitness of the part for its intended use. The dimension of the sealing surfaces area shall be inspected and documented and shall be free of defects.



Stems with threads shall be inspected for missing or incomplete threads, defective thread profile, torn or ruptured surfaces, and cracks.

NOTE The surface texture of threaded parts may be evaluated without magnification.

Rising stems shall be inspected for straightness, finish, and cylindricity.

Stem heads or other connectors shall engage properly with the mating component.

#### **A.5.4 Pressure-Controlling Parts (Gate, Ball, Plug, Disc, Seats, Clappers, etc.)**

Pressure-controlling parts shall be visually inspected for corrosion, wear, pitting, erosive wear, or other defects.

#### **A.5.5 Bearings**

Bearings shall be free of damage, excessive corrosion, or wear. Coatings or liners shall not be torn, damaged, or excessively worn. Operation shall be smooth. If these requirements cannot be satisfied, bearings shall be replaced.

#### **A.5.6 Stem Nut (Gate and Rising Stem Ball Valves)**

Visually inspect the stem nut and stem housing for corrosion, galling, or wear on the bearing surfaces. Internal and external threads shall be visually inspected for condition and engagement with the external stem threads.

#### **A.5.7 Body-to-Bonnet/End Connector/Cover Bolting**

Unless specified otherwise by the owner, all pressure-boundary bolting shall be replaced. Replacement bolting shall conform to Section 8.

#### **A.5.8 Other Components**

Other components shall be visually inspected, and items that need to be replaced or remanufactured shall be processed in accordance with the repairer/remanufacturer procedures.

### **A.6 Repair/Remanufacture/Replacement of Valve Parts**

#### **A.6.1 Control of Manufacturing Operations**

Repair and remanufacture operations shall be performed in accordance with documented procedures.

#### **A.6.2 Replacement Parts and Material**

##### **A.6.2.1 Material**

Materials used for replacement parts shall conform to Section 6.

The source of replacement parts shall be either OEM replacement parts or non-OEM parts that meet the requirements of A.6.2.2.

##### **A.6.2.2 Replacement Parts**

Non-OEM parts shall meet the requirements of Table A.5.

#### **A.6.3 Welding**

Welding, including repair welding procedures and welder/welding operators' qualifications, shall conform to 7.4.

Procedures for non-pressure-containing or non-load bearing welds shall be qualified per the remanufacturer's requirements.

When post-weld heat treatment is required, it shall conform to Section 7.

**Table A.5—Requirements for Replacement Parts of Non-OEM Parts**

Replacement	Minimum Design	Material Requirements	Inspection and Test
<b>Body, End Connectors</b>			
No	N/A	N/A	N/A
<b>Top Plate, Bonnet</b>			
Yes <sup>a,b</sup>	Pressure and load calculations as required.	Traceability and part of data package. PMI for all materials except carbon and low-alloy steel.	PT or MT of machined surfaces and part of data package. Installed and operational as part of the body hydrotest.
<b>Stem</b>			
Yes <sup>a,b</sup>	Full stress analysis for the maximum actuator/gearbox torque or force.	Traceability and part of data package. PMI for all materials except carbon and low-alloy steel.	PT or MT of machined surfaces and part of data package. Installed and operational as part of the body hydrotest.
<b>Seat Inserts in Original Seat Rings</b>			
Yes <sup>a,c</sup>	None.	Material certificates and/or certificates of conformance for insert materials.	Evidence that the repairer has knowledge, equipment, and experience to re-insert seat seals. Part of seat test. Valve shall be stroked under full differential pressure to demonstrate the stability of the seat ring and insert. The valve shall then be seat tested again to demonstrate sealing capability.
<b>New Metallic Seat Rings with New Inserts</b>			
Yes <sup>a,c</sup>	Demonstration that seat ring is manufactured from material with equivalent performance to the original. In addition, demonstration that surface finish, squeeze, fill, and extrusion gap requirements of seal manufacturer are met.	Material certificates and/or certificates of conformance or insert materials.	Evidence that the repairer has knowledge, equipment, and experience to re-insert seat seals. Part of seat test. Valve shall be stroked under full differential pressure to demonstrate the stability of the seat ring and insert. The valve shall then be seat tested again to demonstrate sealing capability. In addition, and where relevant, demonstrate cavity relief functionality.

Replacement	Minimum Design	Material Requirements	Inspection and Test
<b>Bearings</b>			
Yes <sup>a</sup>	Calculations to demonstrate the pressure, velocity, and pressure x velocity criteria are not exceeded for the bearing.	Calculations included and certificates of conformance for bearings. PMI of backing material if in special alloys or specifically requested.	Function test at full differential pressure shall be performed a minimum of three times to demonstrate the performance of the bearings. The valve torque or input force shall be measured and shall not increase by more than 10 %. The valve input torque or thrust shall not exceed the values listed in 5.4.2.1. NOTE May be the same test for seat insert performance.
<b>Valve Closure Member (i.e., Ball, Gate, Plug as Appropriate)</b>			
Yes <sup>a,b</sup>	Demonstration that the closure member design meets the requirements of this document or the document in effect at the time of the original manufacture.	Material certificates. Traceability.	Valve seat and performance test.
<b>Springs (Inside the Valve)</b>			
Yes <sup>a</sup>	Demonstration that the stiffness and free length meets the requirements of this document or the document in effect at the time of the original manufacture.	Material certificates or certificates of conformance. NACE MR0175/ISO 15156 compliance if required.	Valve performance testing.
<b>Elastomers</b>			
Yes <sup>a,c</sup>	Calculations for squeeze, fill, and extrusion.	Certificates of conformance.	Valve performance testing.
<b>Polymeric Seals and Lip Seals</b>			
Yes <sup>a,c</sup>	None.	Certificates of conformance.	Surface finish checks of housings.
<b>Pressure-Boundary Bolts (Like-for-like Replacement)</b>			
Yes	None.	Material certification.	Valve pressure test.
<b>Pressure-Boundary Bolts, Change of Material</b>			
Yes <sup>a</sup>	Pressure containment calculations to verify the design meets the requirements of this document or the document in effect at the time of the original manufacture.	Material certification.	Valve test pressure.
<b>Ancillary Fittings including Injectors</b>			
Yes	None.	Material certification including pressure test.	Pressure test.
<sup>a</sup> When agreed. <sup>b</sup> Alternative materials to original manufacture may be used, provided they meet or exceed the original properties. <sup>c</sup> Any change to original material shall be by agreement, but doing so may invalidate fire-safe certification of the original valve.			

#### **A.6.4 Nondestructive Examination**

If applicable, NDE shall be performed and evaluated by ASNT SNT-TC-1A or ISO 9712 Level II qualified technicians. Procedures for the NDE evaluation method/acceptance shall conform to Annex I.

#### **A.6.5 Valve End Connector Modifications**

RF flange valves may be converted to RTJ or RTJ flanges may be converted to RF when requested by the purchaser, and shall meet the requirements of 5.2.

Conversion from weld-end to flanged-end or flanged-end to weld-end shall be done by agreement with the purchaser.

NOTE Modifications are typically accomplished by weld deposits and subsequent machining.

#### **A.7 Reassembly**

Reassembly of repaired/remanufactured valves shall conform to 9.6.

When specified by the owner, no lubricant shall be used on valves during assembly. If minimal lubricant is required, the repairer/remanufacturer shall supply details to the owner for evaluation.

Repainting or recoating shall conform to the repairer's/remanufacturer's documented procedures, unless otherwise agreed.

#### **A.8 Final Acceptance—Pressure Testing**

Repaired/remanufactured valves shall be pressure tested in accordance with the requirements of Section 10.

#### **A.9 Equipment Marking**

Repaired/remanufactured valves shall have a new nameplate in accordance with the requirements of 12.3.

NOTE As noted in A.4.1.2, the original nameplate remains intact on the valve.

Information on the nameplate shall conform to Table A.6.

**Table A.6 —Nameplate Marking Requirements**

Marking	Format
Remanufacturer or repairer name	ABC Valve Repair Company
6DRM or 6DR	6DRM (remanufacturer) or 6DR (repairer)
Unique identifier number	R/RM-XXXXXXXXXXXXXXXXXX-XX
Date of remanufacture/repair	DORM/R MM-YY or DOM/R MM-YYYY
Pressure class	150/300/600/900/1500/2500
Face-to-face/end-to-end dimensions	26.00 in. (660 mm)
Trim identification: material grade symbols indicating metallic materials for: — stem; — sealing faces; — closure members.	17-4 316SS LF2
Nominal valve size a) full-opening valves: nominal valve size; b) reduced-opening valves.	8 NPS (200DN) 8X6 NPS (200X150 DN) or 8R (186)

If an end connector is modified from RTJ to RF (see A.6.5), the R-number, when visible, shall be removed from the valve body and the end connector.

If an end connector is modified from RF to RTJ (see A.6.5), the R-number shall be marked on the end connector.

In addition to the nameplate, the unique identifier number shall be marked on the body.

## A.10 Preparation for Shipment and Short-term Storage

Repaired/remanufactured valves shall be prepared for shipment, and short-term storage shall conform to the requirements of Section 13.

## A.11 Documentation

The documentation related to the repair or remanufacture listed below shall be maintained by the repairer/remanufacturer for a minimum of 10 years following the date of repair or remanufacture:

- design documentation;
- weld procedure specification (WPS);
- weld procedure qualification record (PQR);
- NDE records (for RT, minimum NDE records are reader sheets and technique sheet) or surface NDE (MT or PT) or UT when performed per Annex I;
- visual inspection records of castings (see 9.4.2);
- chloride content in the hydrostatic test water (see 10.1.2);
- as-received inspection results (see Table A.1);
- photographic evidence (see Table A.2);

- nameplates/tags (or a photograph or scan of the tag) from the previous repairer/remanufacturer that have been removed (see A.4.1.2);
- unique identifier number (see A.4.1.2):
  - 1) material test report for bonnet/cover, stem, and additional related requirements of Annex I;
  - 2) pressure test results (including hydrostatic and or gas) and additional related requirements of Annex I.

NOTE Purchaser or regulatory requirements can specify additional records or a longer record retention period.

The documentation shall be provided by the manufacturer in legible, retrievable, and reproducible form, and free of damage.

Documentation shall include the reason of repair/remanufacturing, types of repairs performed, and parts replaced.

## **Annex B** **(informative)**

### **Examples of Valve Configurations**

This annex shows examples of possible configurations for gate, plug, ball, check, and axial valves with flanged and welding ends for illustration purposes only. Other configurations not shown in this annex of the same type of valve may apply.

Figure B.1—Axial Valve

Figure B.2—Ball Valve (Floating)

Figure B.3—Ball Valve (Side-entry Trunnion Mounted)

Figure B.4—Ball Valve (Top-entry Trunnion Mounted)

Figure B.5—Ball Valve (Welded-body Trunnion Mounted)

Figure B.6—Check Valve (Axial Flow)

Figure B.7—Check Valve (Full-opening Swing)

Figure B.8—Check Valve (Long Pattern, Single-plate Wafer-type)

Figure B.9—Check Valve (Long Pattern, Typical Dual-plate Wafer-type)

Figure B.10—Check Valve (Piston)

Figure B.11—Check Valve (Reduced-opening Swing)

Figure B.12—Check Valve (Short Pattern, Single-plate Wafer-type)

Figure B.13—Gate Valve (Expanding-gate/Rising-stem)

Figure B.14—Gate Valve (Slab-gate/Through-conduit Rising-stem)

Figure B.15—Plug Valve

Figure B.16—Rising Stem Ball Valve

**Key**

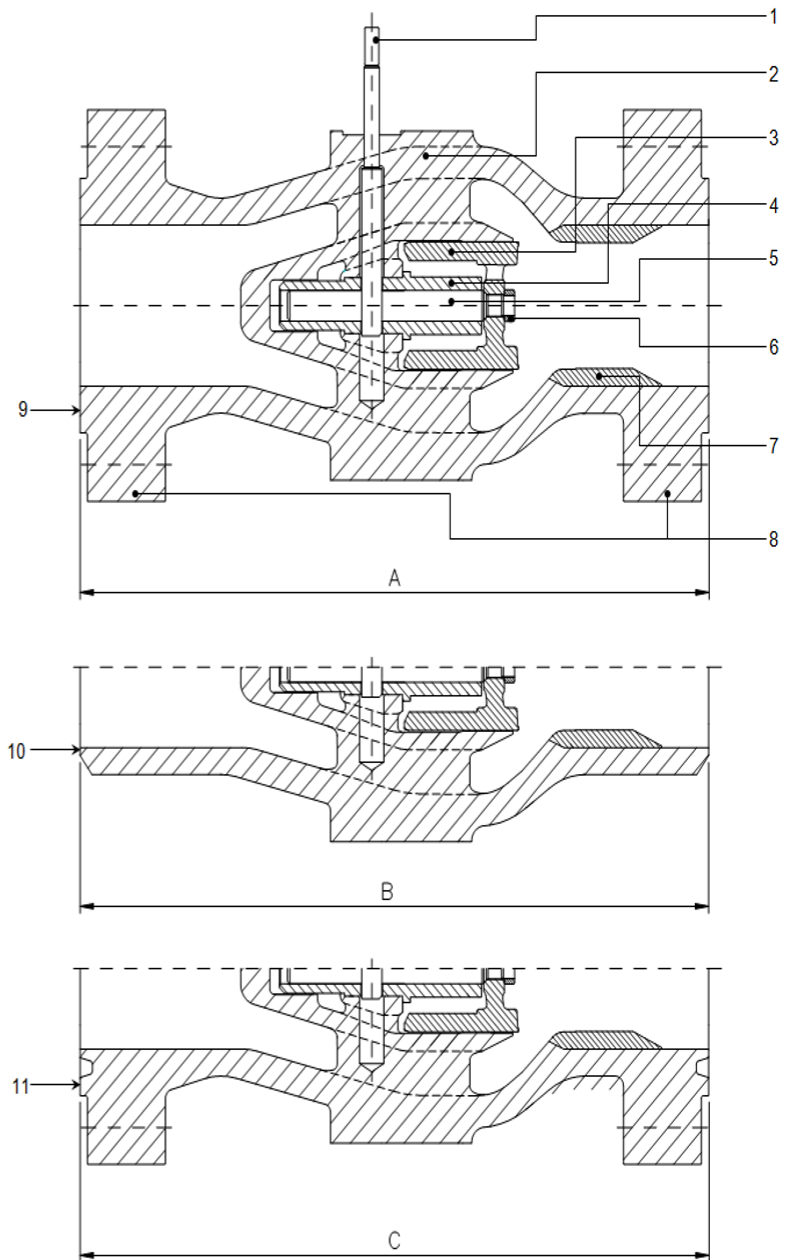
- 1 stem
- 2 body
- 3 piston/closure element
- 4 piston rod guide
- 5 piston rod
- 6 piston nut
- 7 seat ring
- 8 end connector
- 9 raised face
- 10 weld end
- 11 ring joint groove

*A* raised-face face-to-face dimension

*B* weld-end end-to-end dimension

*C* ring joint end-to-end dimension

NOTE See applicable table in Annex C  
for dimensions *A*, *B*, and *C*.



**Figure B.1—Axial Valve**

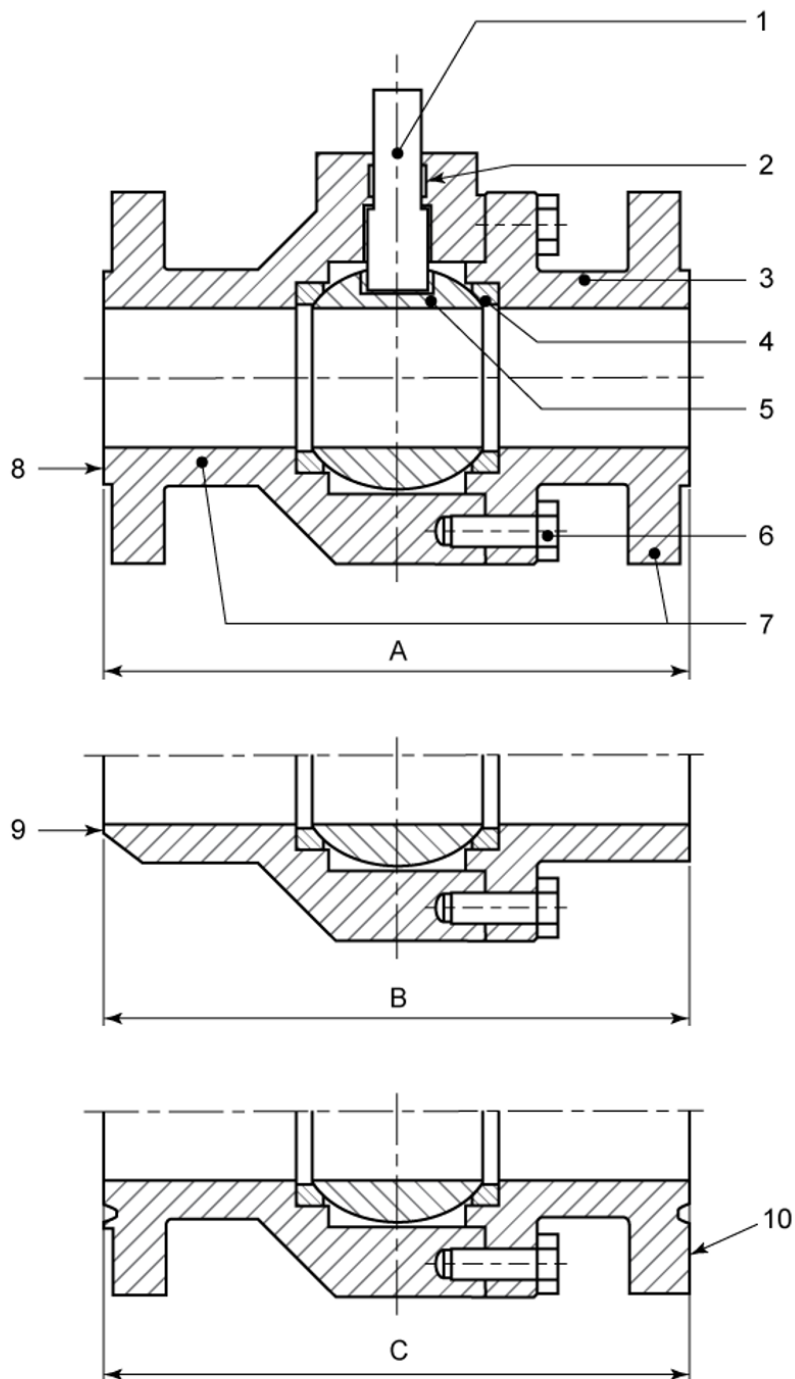


**Key**

- 1 stem
- 2 stem seal
- 3 end connector
- 4 seat ring
- 5 ball/closure element
- 6 body bolting
- 7 body
- 8 raised face
- 9 weld end
- 10 ring joint groove

- A raised-face face-to-face dimension
- B weld-end end-to-end dimension
- C ring joint end-to-end dimension

NOTE See applicable table in Annex C for dimensions A, B, and C.



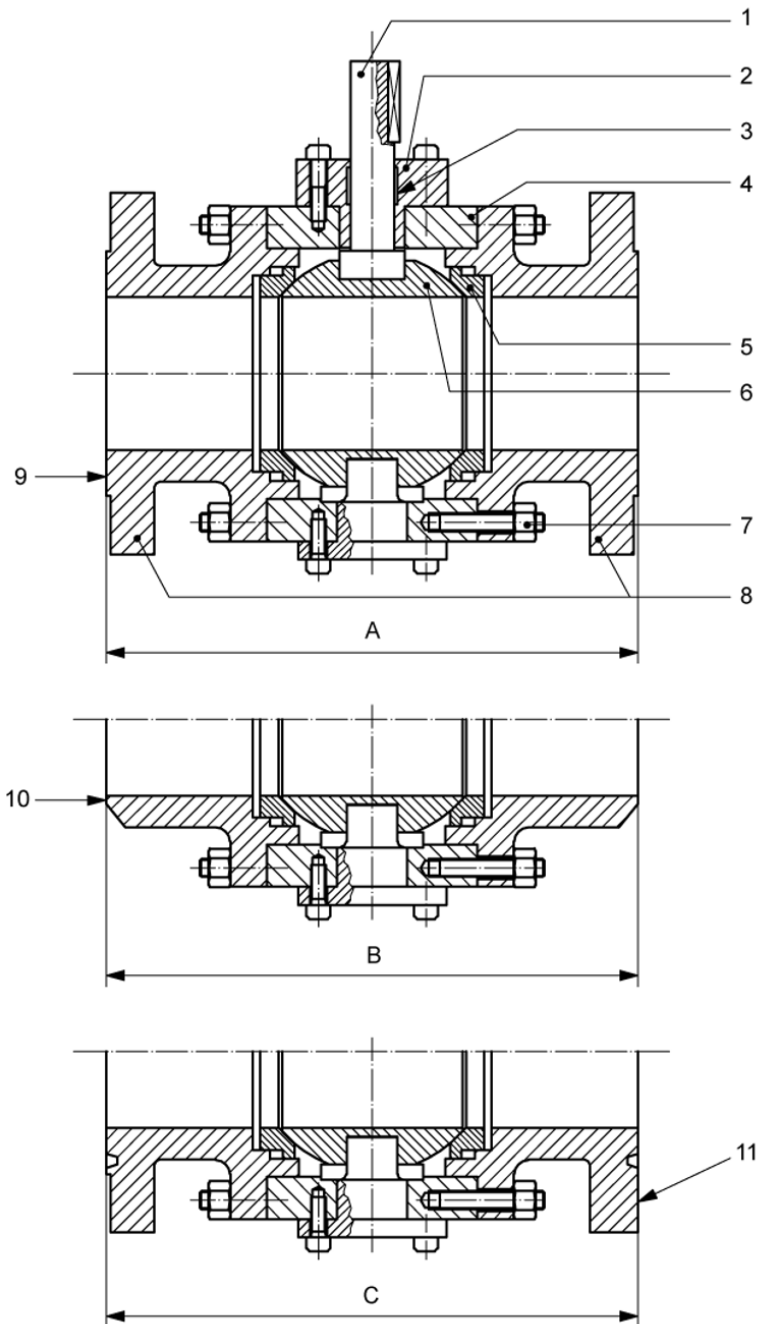
**Figure B.2—Ball Valve (Floating)**

**Key**

- 1 stem
- 2 body cover
- 3 stem seal
- 4 body
- 5 seat ring
- 6 ball/closure element
- 7 body bolting
- 8 end connector
- 9 raised face
- 10 weld end
- 11 ring joint groove

- A raised-face face-to-face dimension
- B weld-end end-to-end dimension
- C ring joint end-to-end dimension

NOTE See applicable table in Annex C for dimensions A, B, and C.



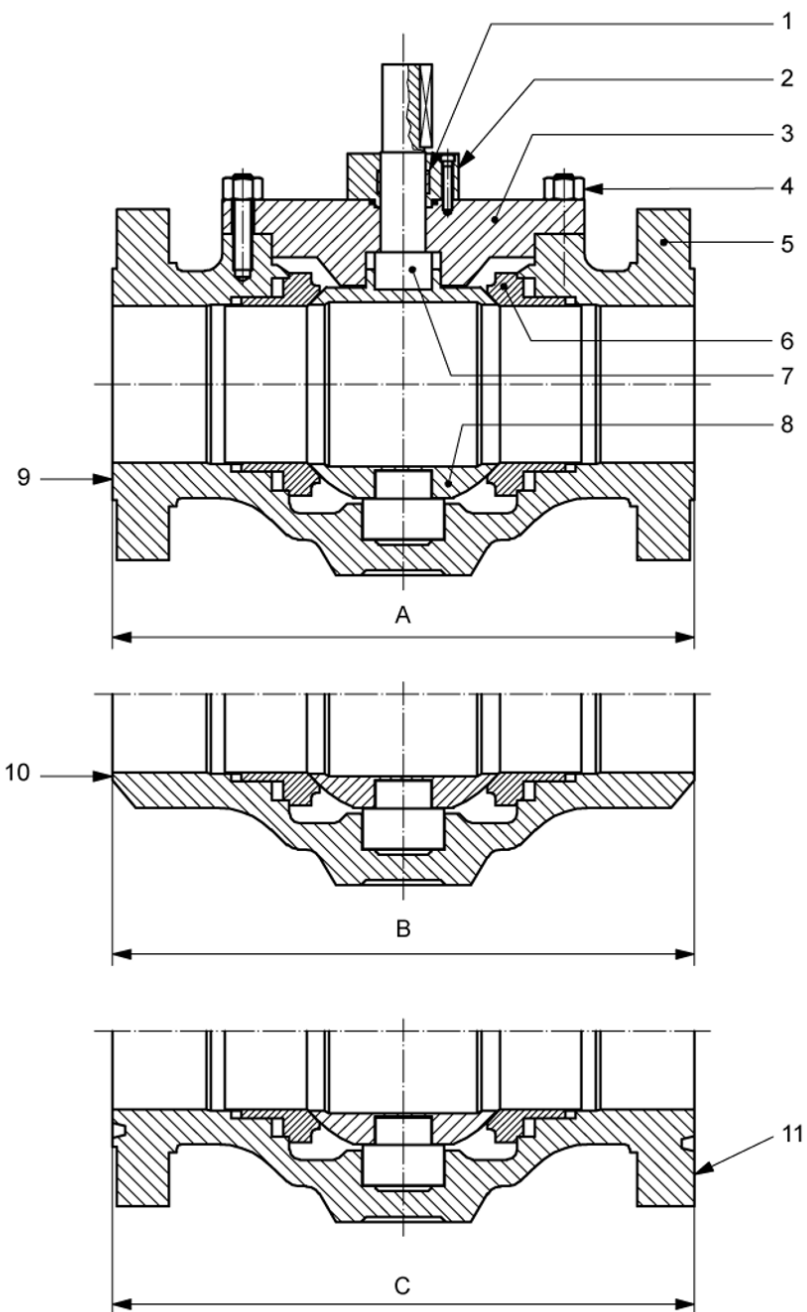
**Figure B.3—Ball Valve (Side-entry Trunnion Mounted)**

**Key**

- 1 stem seal
- 2 bonnet cover
- 3 bonnet
- 4 body bolting
- 5 body
- 6 seat ring
- 7 stem
- 8 ball/closure element
- 9 raised face
- 10 weld end
- 11 ring joint groove

- A raised-face face-to-face dimension
- B weld-end end-to-end dimension
- C ring joint end-to-end dimension

NOTE See applicable table in Annex C for dimensions A, B, and C.



**Figure B.4—Ball Valve (Top-entry Trunnion Mounted)**

**Key**

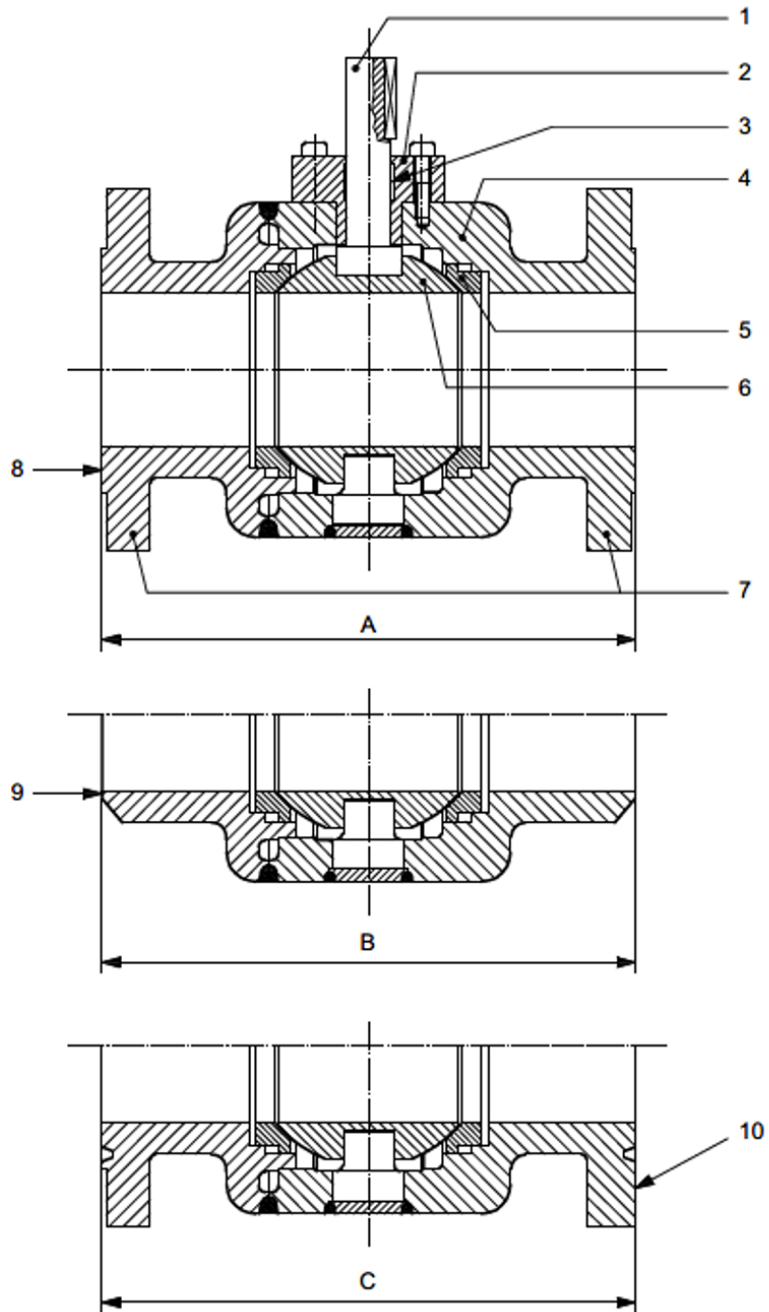
- 1 stem
- 2 body cover
- 3 stem seal
- 4 body
- 5 seat ring
- 6 ball/closure element
- 7 end connector
- 8 raised face
- 9 weld end
- 10 ring joint groove

A raised-face face-to-face dimension

B weld-end end-to-end dimension

C ring joint end-to-end dimension

NOTE See applicable table in Annex C for dimensions A, B, and C.



**Figure B.5—Ball Valve (Welded-body Trunnion Mounted)**

**Key**

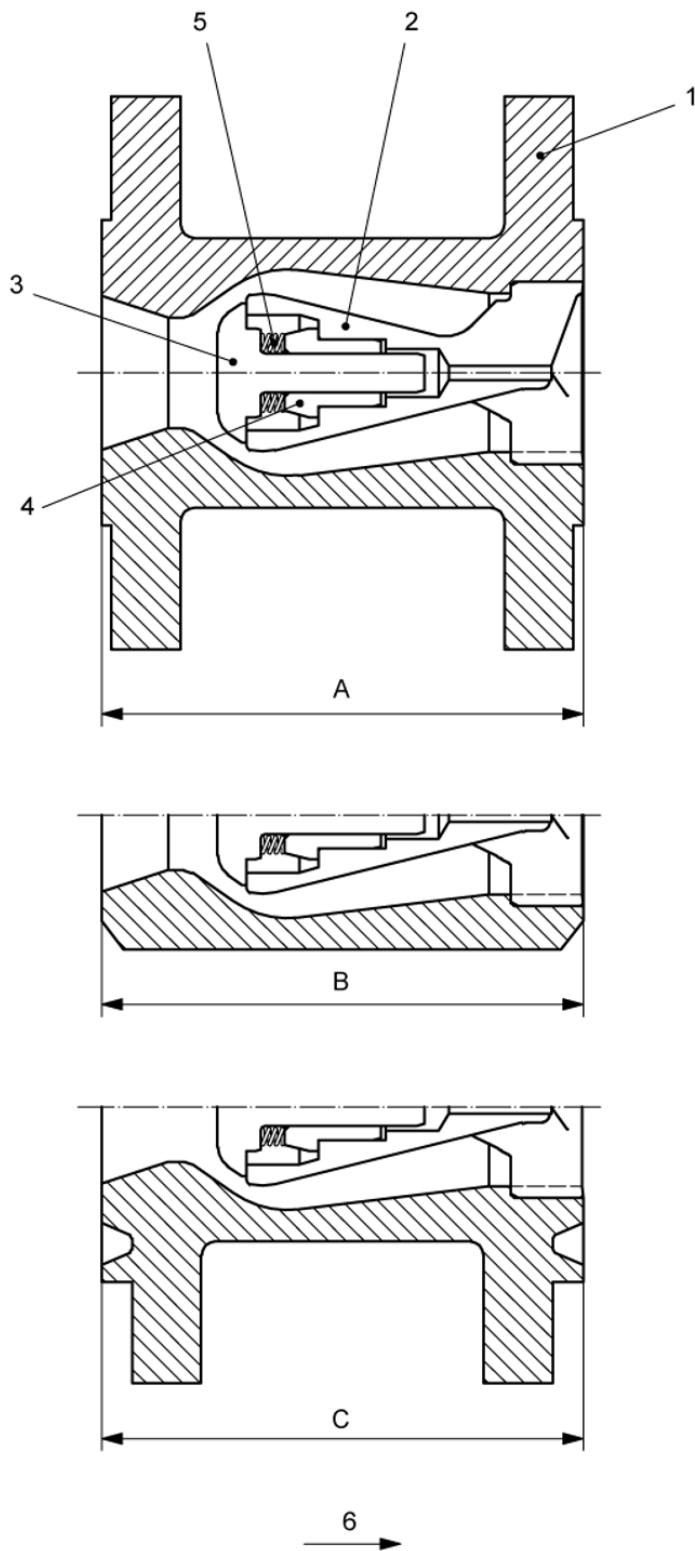
- 1 body
- 2 rod guidance
- 3 disc/closure element
- 4 bearing
- 5 spring
- 6 direction of flow

A raised-face face-to-face dimension

B weld-end end-to-end dimension

C ring joint end-to-end dimension

NOTE See applicable table in Annex C for dimensions A, B, and C.



**Figure B.6—Check Valve (Axial Flow)**

**Key**

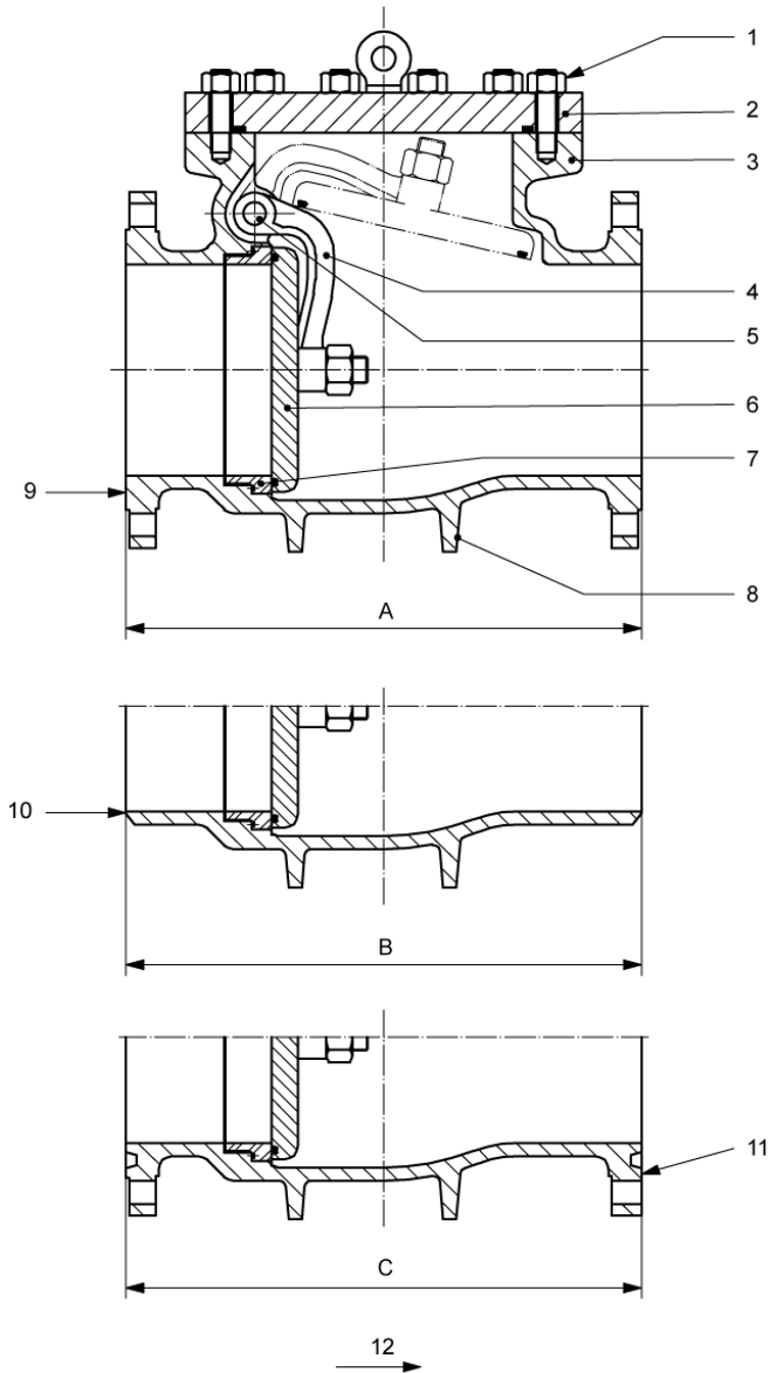
- 1 cover bolting
- 2 cover
- 3 body
- 4 clapper disc arm
- 5 shaft
- 6 clapper/disc/closure element
- 7 seat ring
- 8 support legs
- 9 raised face
- 10 weld end
- 11 ring joint
- 12 direction of flow

A raised-face face-to-face dimension

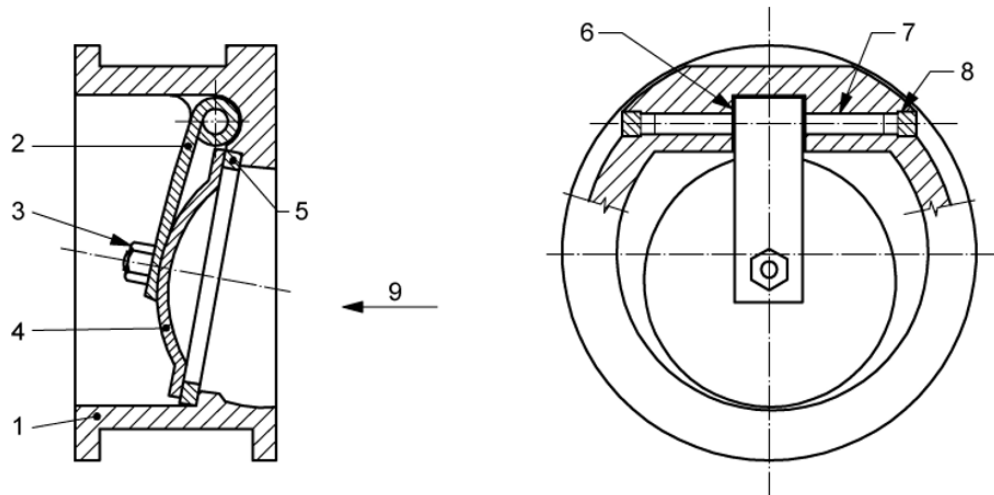
B weld-end end-to-end dimension

C ring joint end-to-end dimension

NOTE See Table C.1 to Table C.5  
for dimensions A, B, and C.



**Figure B.7—Check Valve (Full-opening Swing)**

**Key**

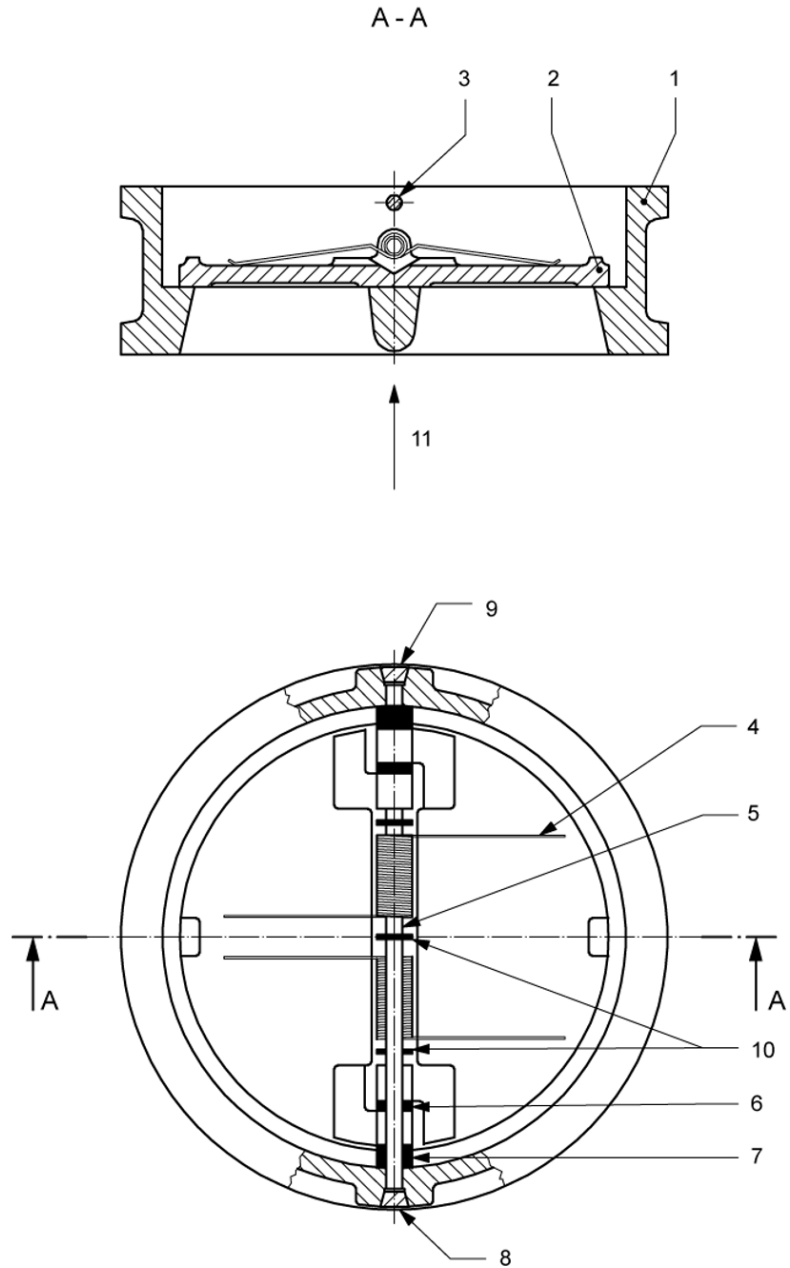
- 1 body
- 2 hinge
- 3 nut
- 4 closure plate/closure element
- 5 seat ring
- 6 bearing spacers
- 7 shaft hinge pin
- 8 shaft retainers
- 9 direction of flow

NOTE: See applicable table in Annex C.

**Figure B.8—Check Valve (Long Pattern, Single-plate Wafer-type)**

**Key**

- 1 body
- 2 closure plate/closure element
- 3 stop pin
- 4 spring
- 5 shaft hinge pin
- 6 plate lug bearings
- 7 body lug bearings
- 8 stop pin retainers
- 9 shaft retainers
- 10 spring bearings
- 11 direction of flow



NOTE: See applicable table in Annex C.

**Figure B.9—Check Valve (Long Pattern, Typical Dual-plate Wafer-type)**

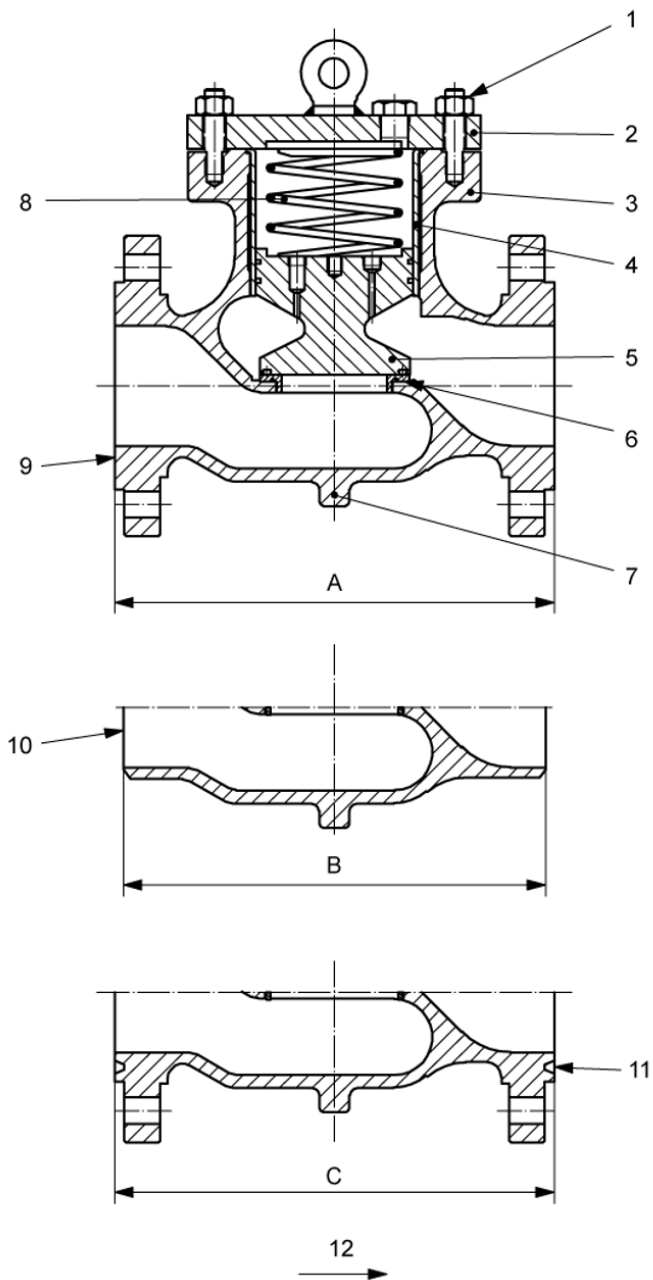


**Key**

- 1 cover bolting
- 2 cover
- 3 body
- 4 liner
- 5 piston/closure element
- 6 seat ring
- 7 support legs
- 8 spring
- 9 raised face
- 10 weld end
- 11 ring joint groove
- 12 direction of flow

- A raised-face face-to-face dimension
- B weld-end end-to-end dimension
- C ring joint end-to-end dimension

NOTE See applicable table in Annex C for dimensions A, B, and C.



**Figure B.10—Check Valve (Piston)**

**Key**

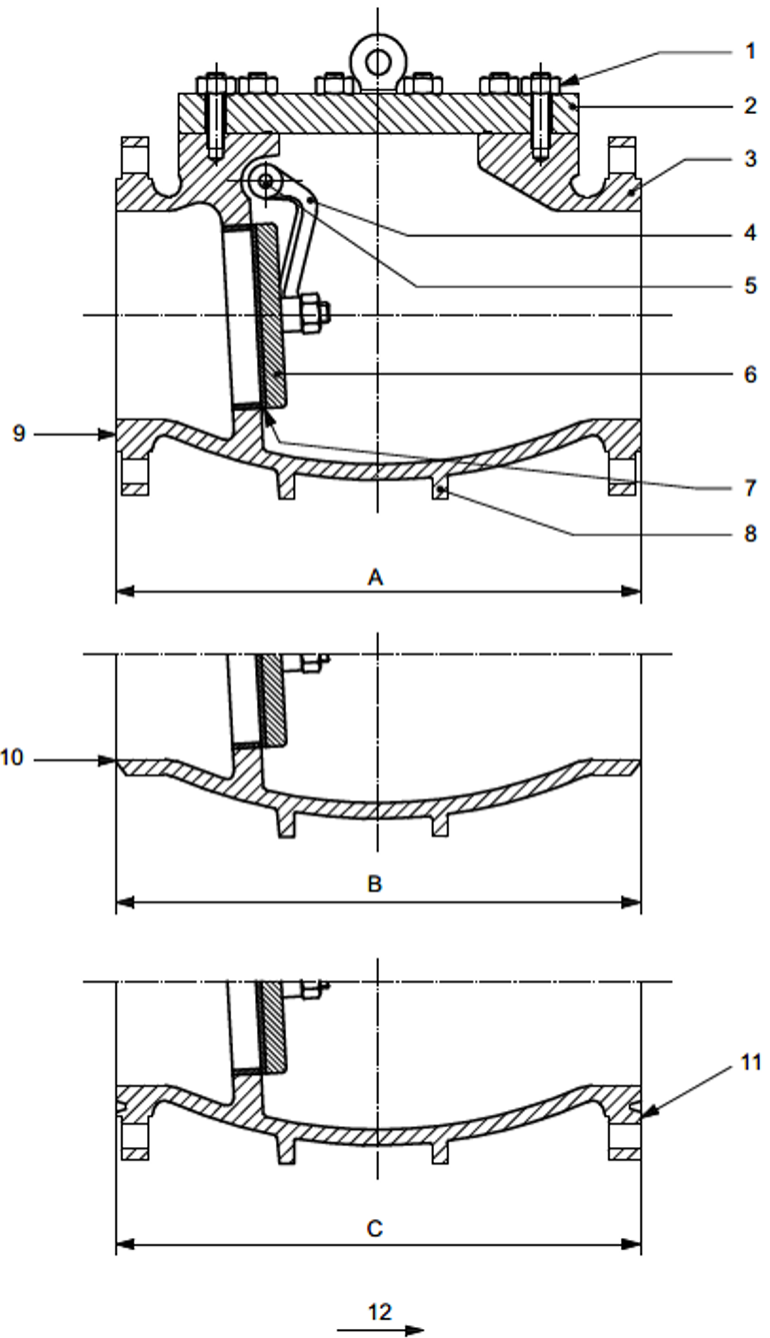
- 1 cover bolting
- 2 cover
- 3 body
- 4 clapper disc arm
- 5 shaft
- 6 clapper disc/closure element
- 7 seat ring
- 8 support legs
- 9 raised face
- 10 weld end
- 11 ring joint groove
- 12 direction of flow

A raised-face face-to-face dimension

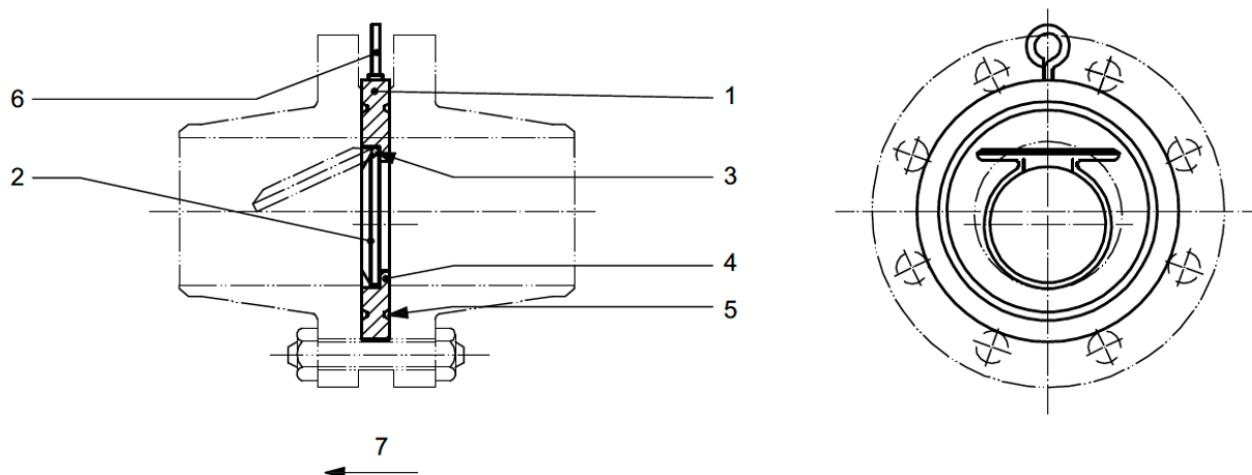
B weld-end end-to-end dimension

C ring joint end-to-end dimension

NOTE See applicable table in Annex C for dimensions A, B, and C.



**Figure B.11—Check Valve (Reduced-opening Swing)**

**Key**

- 1 body
- 2 clapper/disc/closure element
- 3 pin
- 4 clapper seal
- 5 body seal
- 6 lifting eye
- 7 direction of flow

NOTE: See applicable table in Annex C.

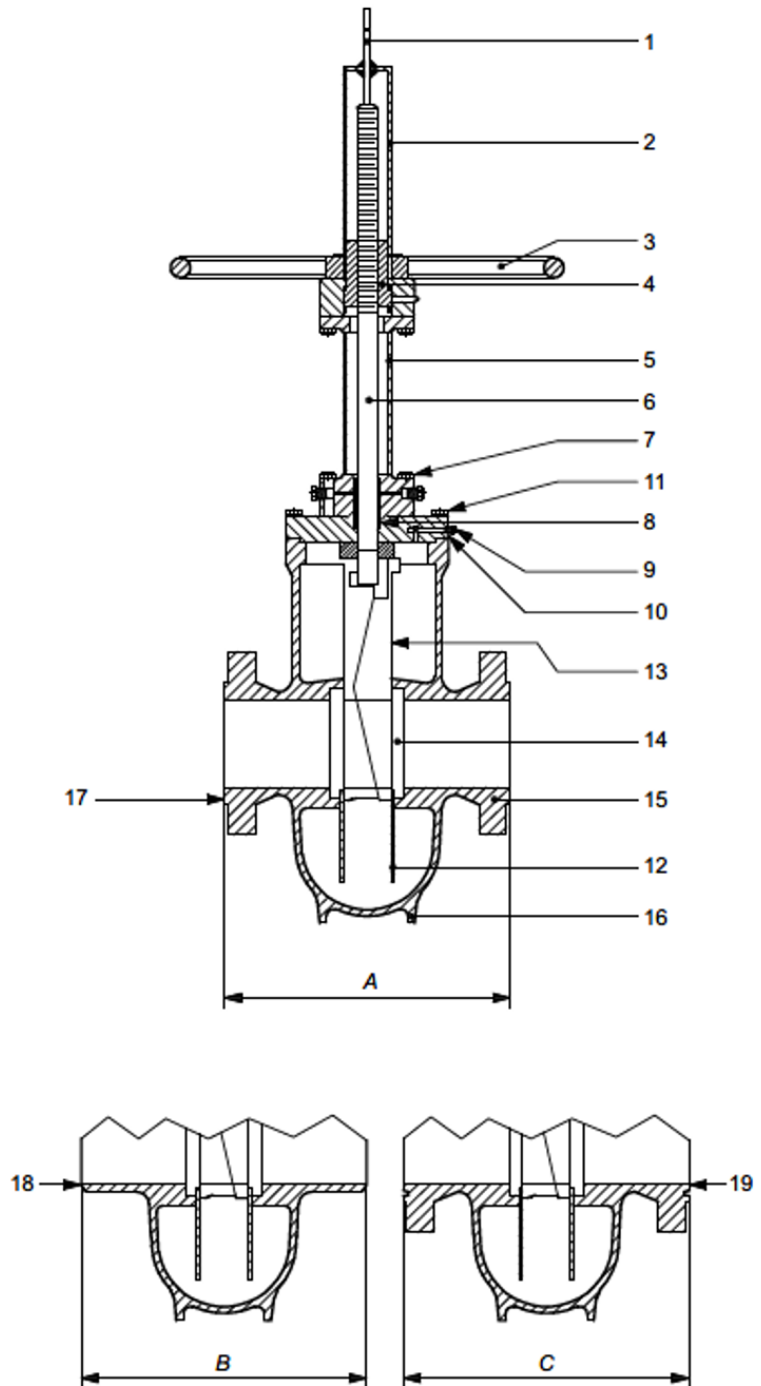
**Figure B.12—Check Valve (Short Pattern, Single-plate Wafer-type)**

**Key**

- 1 stem indicator
- 2 stem enclosure
- 3 hand-wheel
- 4 yoke nut
- 5 yoke
- 6 stem
- 7 yoke bolting
- 8 stem packing
- 9 relief valve
- 10 bonnet
- 11 bonnet bolting
- 12 gate guide
- 13 gate assembly/closure element
- 14 seat ring
- 15 body
- 16 support ribs or legs
- 17 raised face
- 18 weld end
- 19 ring joint groove

- A raised-face face-to-face dimension
- B weld-end end-to-end dimension
- C ring joint end-to-end dimension

NOTE See applicable table in Annex C for dimensions A, B, and C.



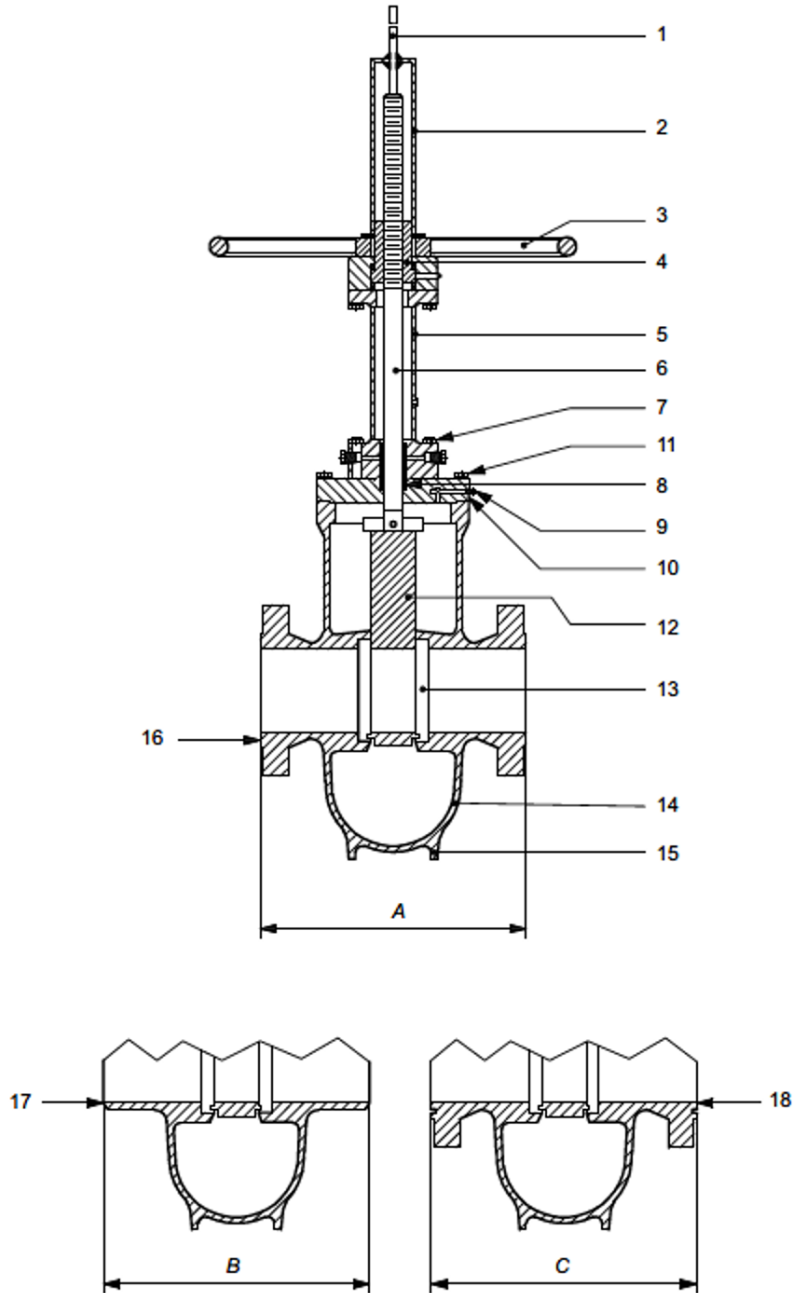
**Figure B.13—Gate Valve (Expanding-gate/Rising-stem)**

**Key**

- 1 stem indicator
- 2 stem enclosure
- 3 hand-wheel
- 4 yoke nut
- 5 yoke
- 6 stem
- 7 yoke bolting
- 8 stem packing
- 9 relief valve
- 10 bonnet
- 11 bonnet bolting
- 12 gate/closure element
- 13 seat ring
- 14 body
- 15 support ribs or legs
- 16 raised face
- 17 weld end
- 18 ring joint groove

- A raised-face face-to-face dimension
- B weld-end end-to-end dimension
- C ring joint end-to-end dimension

NOTE See applicable table in Annex C for dimensions A, B, and C.



**Figure B.14—Gate Valve (Slab-gate/Through-conduit Rising-stem)**

**Key**

- 1 lubricator screw
- 2 gland studs and nuts
- 3 gland
- 4 cover studs and nuts
- 5 cover
- 6 cover gasket
- 7 stem packing
- 8 lubricant check valve
- 9 plug/closure element
- 10 body
- 11 stop collar
- 12 raised face
- 13 weld end
- 14 ring joint groove

- A raised-face face-to-face dimension
- B weld-end end-to-end dimension
- C ring joint end-to-end dimension

NOTE See applicable table in Annex C for dimensions A, B, and C.

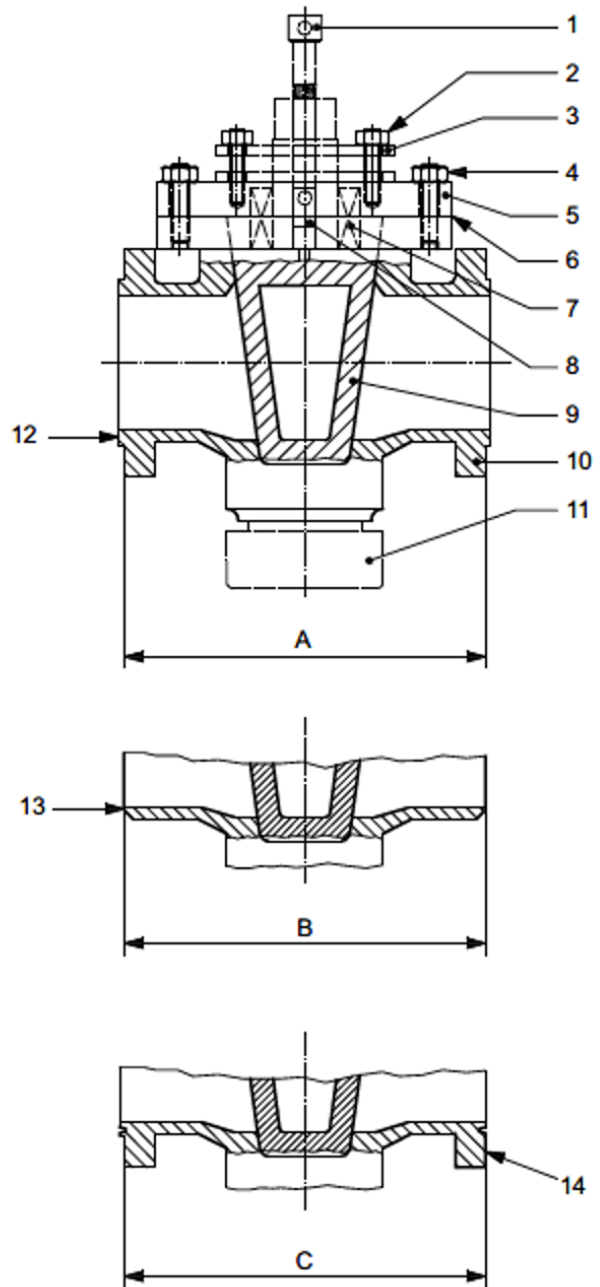


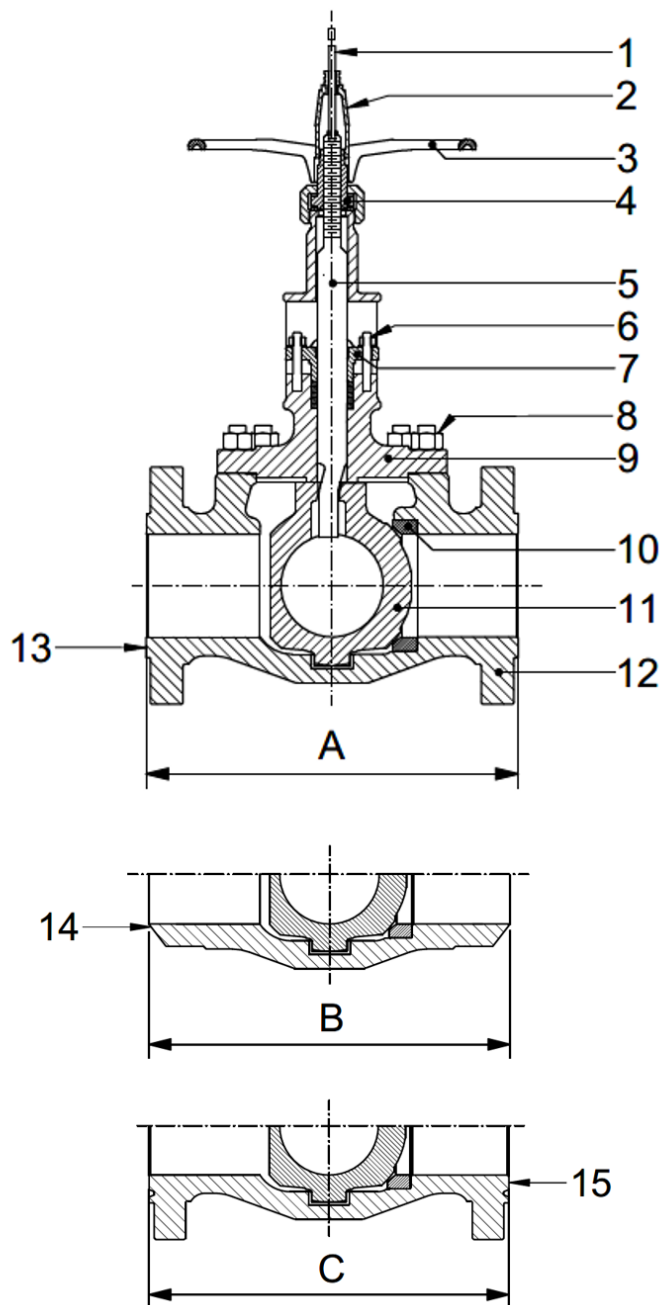
Figure B.15—Plug Valve

**Key**

- 1 stem indicator
- 2 stem enclosure
- 3 handwheel
- 4 drive nut
- 5 stem
- 6 gland studs and nuts
- 7 gland
- 8 bonnet bolting
- 9 bonnet
- 10 seat
- 11 ball/closure element
- 12 body
- 13 raised face
- 14 weld end
- 15 ring joint groove

- A raised-face face-to-face dimension
- B weld-end end-to-end dimension
- C ring joint end-to-end dimension

NOTE See applicable table in Annex C for dimensions A, B, and C.



**Figure B.16—Rising Stem Ball Valve**

*This document is not an API Standard; it is under consideration within an API technical committee but has not received all approvals required to become an API Standard. It shall not be reproduced or circulated or quoted, in whole or in part, outside of API committee activities except with the approval of the Chairman of the committee having jurisdiction and staff of the API Standards Dept. Copyright API. All rights reserved.*

## **Annex C** (normative)

### **Valve End-to-end and Face-to-face Dimensions**

This annex shows valve end-to-end and face-to-face dimensions for gate, plug, ball, check, and axial valves with raised face, weld end, and ring joints.

**Table C.1**—Axial Valves—Face-to-face (A) and End-to-end (B and C) Dimensions

**Table C.2**—Ball Valves—Side-Entry and Top Entry, Face-to-face (A), and End-to-end (B and C) Dimensions

**Table C.3**—Check Valves and Axial Check Valves (Full Opening and Reduced Types)—Face-to-face (A) and End-to-end (B and C) Dimensions

**Table C.4**—Check Valves (Single- and Dual-plate, Long- and Short-pattern, Wafer-type, and Double Flanged)—Face-to-face Dimensions

**Table C.5**—Gate Valves—Face-to-face (A) and End-to-end (B and C) Dimensions

**Table C.6**—Plug Valves—Face-to-face (A) and End-to-end (B and C) Dimensions



**Table C.1—Axial Valves—Face-to-face (A) and End-to-end (B and C) Dimensions<sup>1,2</sup>**

Dimensions in inches (millimeters)

NPS	DN	Raised Face	Weld End	Ring Joint	Raised Face	Weld End	Ring Joint
		A	B	C	A	B	C
Class 150				Class 300			
2	50	11.50 (292)	—	—	11.50 (292)	—	11.63 (295)
2½	65	—	—	—	—	—	—
3	80	14.00 (356)	14.00 (356)	—	14.00 (356)	14.00 (356)	14.13 (359)
4	100	17.00 (432)	17.00 (432)	—	17.00 (432)	17.00 (432)	17.13 (435)
6	150	22.00 (559)	22.00 (559)	—	22.00 (559)	22.00 (559)	22.13 (562)
8	200	26.00 (660)	26.00 (660)	—	26.00 (660)	26.00 (660)	26.13 (664)
10	250	21.00 (533)	22.00 (559)	—	22.38 (568)	22.00 (559)	23.00 (584)
12	300	24.00 (610)	25.00 (635)	—	25.50 (648)	25.00 (635)	26.13 (664)
14	350	27.00 (686)	30.00 (762)	—	30.00 (762)	30.00 (762)	30.63 (778)
16	400	30.00 (762)	33.00 (838)	—	33.00 (838)	33.00 (838)	33.63 (854)
18	450	34.00 (864)	36.00 (914)	—	36.00 (914)	36.00 (914)	36.63 (930)
20	500	36.00 (914)	39.00 (991)	—	39.00 (991)	39.00 (991)	39.75 (1010)
22	550	—	—	—	—	—	—
24	600	42.00 (1067)	45.00 (1143)	—	45.00 (1143)	45.00 (1143)	45.88 (1165)
26	650	—	—	—	—	—	—
28	700	49.00 (1245)	53.00 (1346)	—	53.00 (1346)	53.00 (1346)	54.00 (1372)
30	750	51.00 (1295)	55.00 (1397)	—	55.00 (1397)	55.00 (1397)	56.00 (1422)
32	800	54.00 (1372)	60.00 (1524)	—	60.00 (1524)	60.00 (1524)	61.13 (1553)
34	850	—	—	—	—	—	—
36	900	60.00 (1524)	68.00 (1727)	—	68.00 (1727)	68.00 (1727)	69.13 (1756)
38	950	—	—	—	—	—	—
40	1000	66.00 (1676)	73.60 (1870)	—	73.60 (1870)	73.60 (1870)	—
42	1100	69.00 (1753)	77.00 (1956)	—	77.00 (1956)	77.00 (1956)	—
48	1200	78.00 (1981)	87.25 (2216)	—	87.25 (2216)	87.25 (2216)	—

<sup>1</sup> See Figure B.1 for reference to dimension A, dimension B, and dimension C

<sup>2</sup> Tolerances on standard face-to-face and end-to-end dimensions shall be  $\pm 0.06$  in. ( $\pm 1.5$  mm) for valve sizes smaller than NPS 12 (DN 300), and  $\pm 0.12$  in. ( $\pm 3.0$  mm) for valve sizes NPS 12 (DN 300) and larger.

**Table C.1— Axial Valves—Face-to-face (A) and End-to-end (B and C) Dimensions<sup>1,2</sup> (continued)**

Dimensions in inches (millimeters)

NPS	DN	Raised Face	Weld End	Ring Joint	Raised Face	Weld End	Ring Joint
		A	B	C	A	B	C
Class 600				Class 900			
2	50	11.50 (292)	—	11.63 (295)	14.50 (368)	—	14.63 (371)
2½	65	—	—	—	—	—	—
3	80	14.00 (356)	14.00 (356)	14.13 (359)	15.00 (381)	15.00 (381)	15.13 (384)
4	100	17.00 (432)	17.00 (432)	17.13 (435)	18.00 (457)	18.00 (457)	18.13 (460)
6	150	22.00 (559)	22.00 (559)	22.13 (562)	24.00 (610)	24.00 (610)	24.13 (613)
8	200	26.00 (660)	26.00 (660)	26.13 (664)	29.00 (737)	29.00 (737)	29.13 (740)
10	250	31.00 (787)	31.00 (787)	31.13 (791)	33.00 (838)	33.00 (838)	33.13 (841)
12	300	33.00 (838)	33.00 (838)	33.13 (841)	38.00 (965)	38.00 (965)	38.13 (968)
14	350	35.00 (889)	35.00 (889)	35.13 (892)	40.50 (1029)	40.50 (1029)	40.88 (1038)
16	400	39.00 (991)	39.00 (991)	39.13 (994)	44.50 (1130)	44.50 (1130)	44.88 (1140)
18	450	43.00 (1092)	43.00 (1092)	43.13 (1095)	48.00 (1219)	48.00 (1219)	48.50 (1232)
20	500	47.00 (1194)	47.00 (1194)	47.25 (1200)	52.00 (1321)	52.00 (1321)	52.50 (1334)
22	550	—	—	—	—	—	—
24	600	55.00 (1397)	55.00 (1397)	55.38 (1407)	61.00 (1549)	61.00 (1549)	61.75 (1568)
26	650	—	—	—	—	—	—
28	700	61.00 (1549)	61.00 (1549)	61.50 (1562)	69.00 (1753)	69.00 (1753)	69.88 (1775)
30	750	65.00 (1651)	65.00 (1651)	65.50 (1664)	73.00 (1854)	73.00 (1854)	73.88 (1876)
32	800	70.00 (1778)	70.00 (1778)	70.63 (1794)	77.13 (1959)	77.13 (1959)	78.00 (1981)
34	850	—	—	—	—	—	—
36	900	82.00 (2083)	82.00 (2083)	82.63 (2099)	85.25 (2165)	85.25 (2165)	86.38 (2194)
38	950	—	—	—	—	—	—
40	1000	92.00 (2337)	77.00 (1956)	—	93.50 (2375)	93.50 (2375)	—
42	1100	97.25 (2470)	82.30 (2091)	—	97.65 (2480)	97.65 (2480)	—
48	1200	112.85 (2867)	91.60 (2327)	—	109.88 (2791)	109.88 (2791)	—

<sup>1</sup> See Figure B.1 for reference to dimension A, dimension B, and dimension C

<sup>2</sup> Tolerances on standard face-to-face and end-to-end dimensions shall be  $\pm 0.06$  in. ( $\pm 1.5$  mm) for valve sizes smaller than NPS 12 (DN 300), and  $\pm 0.12$  in. ( $\pm 3.0$  mm) for valve sizes NPS 12 (DN 300) and larger.

**Table C.1— Axial Valves—Face-to-face (A) and End-to-end (B and C) Dimensions<sup>1, 2</sup> (continued)**

Dimensions in inches (millimeters)

NPS	DN	Raised Face	Weld End	Ring Joint	Raised Face	Weld End	Ring Joint
		A	B	C	A	B	C
Class 1500				Class 2500			
2	50	14.50 (368)	—	14.63 (371)	17.75 (451)	—	17.88 (454)
2½	65	—	—	—	—	—	—
3	80	18.50 (470)	15.00 (381)	18.63 (473)	22.75 (578)	16.55 (420)	23.00 (584)
4	100	21.50 (546)	18.00 (457)	21.63 (549)	26.50 (673)	18.00 (457)	26.88 (683)
6	150	27.75 (705)	24.00 (610)	28.00 (711)	36.00 (914)	24.00 (610)	36.50 (927)
8	200	32.75 (832)	29.00 (737)	33.13 (841)	40.25 (1022)	29.00 (737)	40.88 (1038)
10	250	39.00 (991)	33.00 (838)	39.38 (1000)	50.00 (1270)	33.00 (838)	50.88 (1292)
12	300	44.50 (1130)	38.00 (965)	45.13 (1146)	56.00 (1422)	38.00 (965)	56.88 (1445)
14	350	49.50 (1257)	40.50 (1029)	50.25 (1276)	62.75 (1594)	40.50 (1029)	—
16	400	54.50 (1384)	44.50 (1130)	55.38 (1407)	70.00 (1778)	44.50 (1130)	—
18	450	60.12 (1527)	48.00 (1219)	61.00 (1549)	—	—	—
20	500	65.50 (1664)	52.00 (1321)	66.38 (1686)	—	—	—
22	550	—	—	—	—	—	—
24	600	76.26 (1937)	61.00 (1549)	77.36 (1965)	—	—	—

<sup>1</sup> See Figure B.1 for reference to dimension A, dimension B, and dimension C

<sup>2</sup> Tolerances on standard face-to-face and end-to-end dimensions shall be  $\pm 0.06$  in. ( $\pm 1.5$  mm) for valve sizes smaller than NPS 12 (DN 300), and  $\pm 0.12$  in. ( $\pm 3.0$  mm) for valve sizes NPS 12 (DN 300) and larger.

**Table C.2—Ball Valves (Side Entry only)—Face-to-face (A) and End-to-end (B and C) Dimensions<sup>1</sup>,**

Dimensions in inches (millimeters)

NPS	DN	Full Bore and Reduced Bore			Short Pattern, Full Bore, and Reduced Bore		
		Raised Face A	Weld End B	Ring Joint C	Raised Face A	Weld End B	Ring Joint C
		Class 150					
2	50	7.00 (178)	8.50 (216)	7.50 (191)	—	—	—
2½	65	7.50 (191)	9.50 (241)	8.00 (203)	—	—	—
3	80	8.00 (203)	11.13 (283)	8.50 (216)	—	—	—
4	100	9.00 (229)	12.00 (305)	9.50 (241)	—	—	—
6	150	15.50 (394)	18.00 (457)	16.00 (406)	10.50 (267)	15.88 (403)	11.00 (279)
8	200	18.00 (457)	20.50 (521)	18.50 (470)	11.50 (292)	16.50 (419)	12.00 (305)
10	250	21.00 (533)	22.00 (559)	21.50 (546)	13.00 (330)	18.00 (457)	13.50 (343)
12	300	24.00 (610)	25.00 (635)	24.50 (622)	14.00 (356)	19.75 (502)	14.50 (368)
14	350	27.00 (686)	30.00 (762)	27.50 (699)	—	—	—
16	400	30.00 (762)	33.00 (838)	30.50 (775)	—	—	—
18	450	34.00 (864)	36.00 (914)	34.50 (876)	—	—	—
20	500	36.00 (914)	39.00 (991)	36.50 (927)	—	—	—
—	—	—	—	—	—	—	—
24	600	42.00 (1067)	45.00 (1143)	42.50 (1080)	—	—	—
26	650	45.00 (1143)	49.00 (1245)	—	—	—	—
28	700	49.00 (1245)	53.00 (1346)	—	—	—	—
30	750	51.00 (1295)	55.00 (1397)	—	—	—	—
32	800	54.00 (1372)	60.00 (1524)	—	—	—	—
34	850	58.00 (1473)	64.00 (1626)	—	—	—	—
36	900	60.00 (1524)	68.00 (1727)	—	—	—	—

<sup>1</sup> See Figure B.2, Figure B.3, and Figure B.5 for reference to dimension A, dimension B, and dimension C.

<sup>2</sup> Tolerances on standard face-to-face and end-to-end dimensions shall be  $\pm 0.06$  in. ( $\pm 1.5$  mm) for valve sizes smaller than NPS 12 (DN 300), and  $\pm 0.12$  in. ( $\pm 3.0$  mm) for valve sizes NPS 12 (DN 300) and larger.

**Table C.2—Ball Valves (Side Entry only)—Face-to-face (A) and End-to-end (B and C) Dimensions<sup>1,2</sup>  
(continued)**

Dimensions in inches (millimeters)

NPS	DN	Full Bore and Reduced Bore			Short Pattern, Full Bore, and Reduced		
		Raised Face A	Weld End B	Ring Joint C	Raised Face A	Weld End B	Ring Joint C
<b>Class 300</b>							
2	50	8.50 (216)	8.50 (216)	9.13 (232)	—	—	—
2 1/2	65	9.50 (241)	9.50 (241)	10.13 (257)	—	—	—
3	80	11.13 (283)	11.13 (283)	11.75 (298)	—	—	—
4	100	12.00 (305)	12.00 (305)	12.63 (321)	—	—	—
6	150	15.88 (403)	18.00 (457)	16.50 (419)	—	—	—
8	200	19.75 (502)	20.50 (521)	20.38 (518)	16.50 (419)	16.50 (419)	17.13 (435)
10	250	22.38 (568)	22.00 (559)	23.00 (584)	18.00 (457)	18.00 (457)	18.63 (473)
12	300	25.50 (648)	25.00 (635)	26.13 (664)	19.75 (502)	19.75 (502)	20.38 (518)
14	350	30.00 (762)	30.00 (762)	30.63 (778)	—	—	—
16	400	33.00 (838)	33.00 (838)	33.63 (854)	—	—	—
18	450	36.00 (914)	36.00 (914)	36.63 (930)	—	—	—
20	500	39.00 (991)	39.00 (991)	39.75 (1010)	—	—	—
22	550	43.00 (1092)	43.00 (1092)	43.88 (1114)	—	—	—
24	600	45.00 (1143)	45.00 (1143)	45.88 (1165)	—	—	—
26	650	49.00 (1245)	49.00 (1245)	50.00 (1270)	—	—	—
28	700	53.00 (1346)	53.00 (1346)	54.00 (1372)	—	—	—
30	750	55.00 (1397)	55.00 (1397)	56.00 (1422)	—	—	—
32	800	60.00 (1524)	60.00 (1524)	61.13 (1553)	—	—	—
34	850	64.00 (1626)	64.00 (1626)	65.13 (1654)	—	—	—
36	900	68.00 (1727)	68.00 (1727)	69.13 (1756)	—	—	—

<sup>1</sup> See Figure B.2, Figure B.3, and Figure B.5 for reference to dimension A, dimension B, and dimension C.<sup>2</sup> Tolerances on standard face-to-face and end-to-end dimensions shall be  $\pm 0.06$  in. ( $\pm 1.5$  mm) for valve sizes smaller than NPS 12 (DN 300), and  $\pm 0.12$  in. ( $\pm 3.0$  mm) for valve sizes NPS 12 (DN 300) and larger.

**Table C.2—Ball Valves (Side Entry and Top Entry)—Face-to-face (A) and End-to-end (B and C) Dimensions<sup>1,2</sup> (continued)**

Dimensions in inches (millimeters)

NPS	DN	Full Bore, and Reduced Bore			Full Bore, and Reduced Bore		
		Raised Face A	Weld End B	Ring Joint C	Raised Face A	Weld End B	Ring Joint C
		Class 600			Class 900		
2	50	11.50 (292)	11.50 (292)	11.63 (295)	14.50 (368)	14.50 (368)	14.63 (371)
2 1/2	65	13.00 (330)	13.00 (330)	13.13 (333)	16.50 (419)	16.50 (419)	16.63 (422)
3	80	14.00 (356)	14.00 (356)	14.13 (359)	15.00 (381)	15.00 (381)	15.13 (384)
4	100	17.00 (432)	17.00 (432)	17.13 (435)	18.00 (457)	18.00 (457)	18.13 (460)
6	150	22.00 (559)	22.00 (559)	22.13 (562)	24.00 (610)	24.00 (610)	24.13 (613)
8	200	26.00 (660)	26.00 (660)	26.13 (664)	29.00 (737)	29.00 (737)	29.13 (740)
10	250	31.00 (787)	31.00 (787)	31.13 (791)	33.00 (838)	33.00 (838)	33.13 (841)
12	300	33.00 (838)	33.00 (838)	33.13 (841)	38.00 (965)	38.00 (965)	38.13 (968)
14	350	35.00 (889)	35.00 (889)	35.13 (892)	40.50 (1029)	40.50 (1029)	40.88 (1038)
16	400	39.00 (991)	39.00 (991)	39.13 (994)	44.50 (1130)	44.50 (1130)	44.88 (1140)
18	450	43.00 (1092)	43.00 (1092)	43.13 (1095)	48.00 (1219)	48.00 (1219)	48.50 (1232)
20	500	47.00 (1194)	47.00 (1194)	47.25 (1200)	52.00 (1321)	52.00 (1321)	52.50 (1334)
22	550	51.00 (1295)	51.00 (1295)	51.38 (1305)	—	—	—
24	600	55.00 (1397)	55.00 (1397)	55.38 (1407)	61.00 (1549)	61.00 (1549)	61.75 (1568)
26	650	57.00 (1448)	57.00 (1448)	57.50 (1461)	65.00 (1651)	—	65.88 (1673)
28	700	61.00 (1549)	61.00 (1549)	61.50 (1562)	—	—	—
30	750	65.00 (1651)	65.00 (1651)	65.50 (1664)	74.00 (1880)	—	74.88 (1902)
32	800	70.00 (1778)	70.00 (1778)	70.63 (1794)	—	—	—
34	850	76.00 (1930)	76.00 (1930)	76.63 (1946)	—	—	—
36	900	82.00 (2083)	82.00 (2083)	82.63 (2099)	90.00 (2286)	—	91.13 (2315)

<sup>1</sup> See Figure B.2, Figure B.3, and Figure B.5 for reference to dimension A, dimension B, and dimension C.

<sup>2</sup> Tolerances on standard face-to-face and end-to-end dimensions shall be  $\pm 0.06$  in. ( $\pm 1.5$  mm) for valve sizes smaller than NPS 12 (DN 300), and  $\pm 0.12$  in. ( $\pm 3.0$  mm) for valve sizes NPS 12 (DN 300) and larger.

**Table C.2—Ball Valves (Side Entry and Top Entry)—Face-to-face (A) and End-to-end (B and C) Dimensions<sup>1, 2</sup> (continued)**

Dimensions in inches (millimeters)

NPS	DN	Full Bore and Reduced Bore			Full Bore, and Reduced Bore		
		Raised Face A	Weld End B	Ring Joint C	Raised Face A	Weld End B	Ring Joint C
		Class 1500			Class 2500		
2	50	14.50 (368)	14.50 (368)	14.63 (371)	17.75 (451)	17.75 (451)	17.88 (454)
2 1/2	65	16.50 (419)	16.50 (419)	16.63 (422)	20.00 (508)	20.00 (508)	20.25 (514)
3	80	18.50 (470)	18.50 (470)	18.63 (473)	22.75 (578)	22.75 (578)	23.00 (584)
4	100	21.50 (546)	21.50 (546)	21.63 (549)	26.50 (673)	26.50 (673)	26.88 (683)
6	150	27.75 (705)	27.75 (705)	28.00 (711)	36.00 (914)	36.00 (914)	36.50 (927)
8	200	32.75 (832)	32.75 (832)	33.13 (841)	40.25 (1022)	40.25 (1022)	40.88 (1038)
10	250	39.00 (991)	39.00 (991)	39.38 (1000)	50.00 (1270)	50.00 (1270)	50.88 (1292)
12	300	44.50 (1130)	44.50 (1130)	45.13 (1146)	56.00 (1422)	56.00 (1422)	56.88 (1445)
14	350	49.50 (1257)	49.50 (1257)	50.25 (1276)	—	—	—
16	400	54.50 (1384)	54.50 (1384)	55.38 (1407)	—	—	—
18	450	60.50 (1537)	—	61.38 (1559)	—	—	—
20	500	65.50 (1664)	—	66.38 (1686)	—	—	—
22	550	—	—	—	—	—	—
24	600	—	—	77.63 (1972)	—	—	—
26	650	76.5 (1943)	—	—	—	—	—

<sup>1</sup> See Figure B.2, Figure B.3, and Figure B.5 for reference to dimension A, dimension B, and dimension C.

<sup>2</sup> Tolerances on standard face-to-face and end-to-end dimensions shall be  $\pm 0.06$  in. ( $\pm 1.5$  mm) for valve sizes smaller than NPS 12 (DN 300), and  $\pm 0.12$  in. ( $\pm 3.0$  mm) for valve sizes NPS 12 (DN 300) and larger.

**Table C.2—Ball Valves (Top-Entry)—Face-to-face (A) and End-to-end (B and C) Dimensions<sup>1,2</sup> (continued)**

Dimensions in inches (millimeters)

NPS	DN	Full Bore, and Reduced Bore		
		Raised Face A	Weld End B	Ring Joint C
		Class 150 and Class 300		
2	50	11.50 (292)	11.50 (292)	11.63 (295)
2 1/2	65	13.00 (330)	13.00 (330)	13.13 (333)
3	80	14.00 (356)	14.00 (356)	14.13 (359)
4	100	17.00 (432)	17.00 (432)	17.13 (435)
6	150	22.00 (559)	22.00 (559)	22.13 (562)
8	200	26.00 (660)	26.00 (660)	26.13 (664)
10	250	31.00 (787)	31.00 (787)	31.13 (791)
12	300	33.00 (838)	33.00 (838)	33.13 (841)
14	350	35.00 (889)	35.00 (889)	35.13 (892)
16	400	39.00 (991)	39.00 (991)	39.13 (994)
18	450	43.00 (1092)	43.00 (1092)	43.13 (1095)
20	500	47.00 (1194)	47.00 (1194)	47.25 (1200)
22	550	51.00 (1295)	51.00 (1295)	51.38 (1305)
24	600	55.00 (1397)	55.00 (1397)	55.38 (1407)
26	650	57.00 (1448)	57.00 (1448)	57.50 (1461)
28	700	61.00 (1549)	61.00 (1549)	61.50 (1562)
30	750	65.00 (1651)	65.00 (1651)	65.50 (1664)
32	800	70.00 (1778)	70.00 (1778)	70.63 (1794)
34	850	76.00 (1930)	76.00 (1930)	76.63 (1946)
36	900	82.00 (2083)	82.00 (2083)	82.63 (2099)

<sup>1</sup> See Figure B.4 for reference to dimension A, dimension B, and dimension C.

<sup>2</sup> Tolerances on standard face-to-face and end-to-end dimensions shall be  $\pm 0.06$  in. ( $\pm 1.5$  mm) for valve sizes smaller than NPS 12 (DN 300), and  $\pm 0.12$  in. ( $\pm 3.0$  mm) for valve sizes NPS 12 (DN 300) and larger.



**Table C.3—Check Valves and Axial Check Valves (Full Opening and Reduced Types)—Face-to-face (A) and End-to-end (B and C) Dimensions<sup>1, 2</sup>**

Dimensions in inches (millimeters)

NPS	DN	Long Pattern Raised Face/ Weld End	Long Pattern Ring Joint	Short Pattern Raised Face and Ring Joint	Compact Pattern Raised Face and Ring Joint
		A/B	C	A/C	A/C
<b>Class 150</b>					
½	15	4.25 (108)	-	1.96 (50)	
¾	20	4.60 (117)	-	2.36 (60)	
1	25	5.00 (127)	5.50 (140)	4.00 (100)	
1¼	32	5.50 (140)	6.00 (153)	4.00 (100)	
1½	40	6.50 (165)	7.00 (178)	4.72 (120)	
2	50	8.00 (203)	8.50 (216)	4.72 (120)	
2½	65	8.50 (216)	9.00 (229)	4.75 (120)	
3	80	9.50 (241)	10.00 (254)	4.75 (120)	
4	100	11.50 (292)	12.00 (305)	5.50 (140)	
6	150	14.00 (356)	14.50 (368)	8.27 (210)	
8	200	19.50 (495)	20.00 (508)	11.02 (280)	
10	250	24.50 (622)	25.00(635)	13.78 (350)	
12	300	27.50 (699)	28.00 (711)	13.78 (350)	7.25 (181)
14	350	31.00 (787)	31.50 (800)	15.94 (405)	8.75 (222)
16	400	34.00 (864)	34.50 (876)	17.91 (455)	9.75 (245)
18	450	38.50 (978)	39.00 (991)	20.47 (520)	10.50 (264)
20	500	38.50 (978)	39.00 (991)	22.44 (570)	12.00 (305)
22	550	42.00 (1067)	42.50 (1080)	22.44 (570)	13.78 (350)
24	600	51.00 (1295)	51.50 (1308)	26.97 (685)	14.50 (370)
26	650	51.00 (1295)	—	29.33 (745)	14.50 (370)
28	700	57.00 (1448)	—	31.50 (800)	17.00 (430)
30	750	60.00 (1524)	—	33.66 (855)	18.00 (460)
32	800	—	—	35.83 (910)	19.75 (500)
34	850	—	—	38.19 (970)	20.87 (530)
36	900	77.00 (1956)	—	40.55 (1030)	24.00 (600)
38	950	—	—	44.69 (1135)	23.23 (590)
40	1000	—	—	44.69 (1135)	25.50 (650)
42	1050	—	—	47.05 (1195)	26.25 (670)
48	1200	—	—	53.74 (1365)	29.25 (740)
54	1350	—	—	60.24 (1530)	32.68 (830)
56	1400	—	—	62.99 (1600)	33.46 (850)
60	1500	—	—	67.32 (1710)	38.19 (970)

<sup>1</sup> See Figure B.6, Figure B.7, Figure B.10, and Figure B.11 for reference to dimension A, dimension B, and dimension C.

<sup>2</sup> Tolerances on standard face-to-face and end-to-end dimensions shall be  $\pm 0.06$  in. ( $\pm 1.5$  mm) for valve sizes smaller than NPS 12 (DN 300), and  $\pm 0.12$  in. ( $\pm 3.0$  mm) for valve sizes NPS 12 (DN 300) and larger.

**Table C.3—Check Valves and Axial Check Valves (Full Opening and Reduced Types)—Face-to-face (A) and End-to-end (B and C) Dimensions<sup>1, 2</sup>**  
(continued)

Dimensions in inches (millimeters)

NPS	DN	Long Pattern Raised Face/ Weld End A/B	Long Pattern Ring Joint C	Short Pattern Raised Face and Ring Joint A/C	Compact Pattern Raised Face and Ring Joint A/C
		Class 300			
½	15	—	—	1.96 (50)	
¾	20	—	—	2.36 (60)	
1	25	8.50 (216)	9.00 (229)	4.00 (100)	
1¼	32	9.00 (229)	9.50 (242)	4.00 (100)	
1½	40	9.50 (241)	10.00 (254)	4.72 (120)	
2	50	10.50 (267)	11.13 (283)	4.72 (120)	
2½	65	11.50 (292)	12.13 (308)	5.91 (150)	
3	80	12.50 (318)	13.13 (333)	5.91 (150)	
4	100	14.00 (356)	14.63 (371)	6.69 (170)	
6	150	17.50 (445)	18.13 (460)	8.27 (210)	
8	200	21.00 (533)	21.63 (549)	11.02 (280)	
10	250	24.50 (622)	25.13 (638)	13.78 (350)	
12	300	28.00 (711)	28.63 (727)	13.78 (350)	7.25 (181)
14	350	33.00 (838)	33.63 (854)	15.94 (405)	8.75 (222)
16	400	34.00 (864)	34.63 (879)	17.91 (455)	9.75 (245)
18	450	38.50 (978)	39.13 (994)	20.47 (520)	10.50 (264)
20	500	40.00 (1016)	40.75 (1035)	22.44 (570)	12.00 (305)
22	550	44.00 (1118)	44.88 (1140)	22.44 (570)	—
24	600	53.00 (1346)	53.88 (1368)	26.97 (685)	14.50 (370)
26	650	53.00 (1346)	54.00 (1372)	29.33 (745)	—
28	700	59.00 (1499)	60.00 (1524)	31.50 (800)	17.00 (430)
30	750	62.75 (1594)	63.75 (1619)	33.66 (855)	18.00 (460)
32	800	—	—	35.83 (910)	19.75 (500)
34	850	—	—	38.19 (970)	—
36	900	82.00 (2083)	83.10 (2111)	40.55 (1030)	24.00 (600)
38	950	—	—	44.69 (1135)	—
40	1000	—	—	44.69 (1135)	25.50 (650)
42	1050	—	—	47.05 (1195)	28.25 (720)
48	1200	—	—	53.74 (1365)	33.00 (840)
54	1350	—	—	60.24 (1530)	—
56	1400	—	—	62.99 (1600)	33.46 (850)
60	1500	—	—	67.32 (1710)	—

<sup>1</sup> See Figure B.6, Figure B.7, Figure B.10, and Figure B.11 for reference to dimension A, dimension B, and dimension C.

<sup>2</sup> Tolerances on standard face-to-face and end-to-end dimensions shall be ±0.06 in. (±1.5 mm) for valve sizes smaller than NPS 12 (DN 300), and ±0.12 in. (±3.0 mm) for valve sizes NPS 12 (DN 300) and larger.

**Table C.3—Check Valves and Axial Check Valves (Full Opening and Reduced Types)—Face-to-face (A) and End-to-end (B and C) Dimensions<sup>1, 2</sup>**  
(continued)

Dimensions in inches (millimeters)

NPS	DN	Long Pattern Raised Face/ Weld End <i>A/B</i>	Long Pattern Ring Joint <i>C</i>	Short Pattern Raised Face and Ring Joint <i>A/C</i>	Compact Pattern Raised Face and Ring Joint <i>A/C</i>
		Class 600			
½	15	6.50 (165)	6.50 (165)	1.96 (50)	
¾	20	7.50 (190)	7.50 (190)	2.36 (60)	
1	25	8.50 (216)	8.50 (216)	4.00 (100)	
1¼	32	9.00 (229)	9.00 (229)	4.00 (100)	
1½	40	9.50 (241)	9.50 (241)	4.72 (120)	
2	50	11.50 (292)	11.63 (295)	4.72 (120)	
2½	65	13.00 (330)	13.13 (333)	5.91 (150)	
3	80	14.00 (356)	14.13 (359)	5.91 (150)	
4	100	17.00 (432)	17.13 (435)	6.69 (170)	
6	150	22.00 (559)	22.13 (562)	8.27 (210)	
8	200	26.00 (660)	26.13 (664)	11.02 (280)	
10	250	31.00 (787)	31.13 (791)	13.78 (350)	
12	300	33.00 (838)	33.13 (841)	14.76 (375)	9.00 (229)
14	350	35.00 (889)	35.13 (892)	17.32 (440)	10.75 (273)
16	400	39.00 (991)	39.13 (994)	19.69 (500)	12.00 (305)
18	450	43.00 (1092)	43.13 (1095)	22.24 (565)	14.25 (362)
20	500	47.00 (1194)	47.25 (1200)	24.61 (625)	14.50 (368)
22	550	51.00 (1295)	51.38 (1305)	26.97 (685)	—
24	600	55.00 (1397)	55.38 (1407)	29.33 (745)	17.25 (438)
26	650	57.00 (1448)	57.50 (1461)	31.89 (810)	18.11 (460)
28	700	63.00 (1600)	63.50 (1613)	34.25 (870)	19.00 (480)
30	750	65.00 (1651)	65.50 (1664)	36.61 (930)	20.00 (505)
32	800	—	—	38.98 (990)	23.00 (584)
34	850	—	—	41.54 (1055)	—
36	900	82.00 (2083)	82.64 (2099)	44.09 (1120)	25.00 (635)
38	950	—	—	45.26 (1175)	—
40	1000	—	—	48.82 (1240)	32.25 (820)
42	1050	—	—	51.18 (1300)	34.25 (870)
48	1200	—	—	58.46 (1485)	38.25 (970)
54	1350	—	—	65.75 (1670)	—
56	1400	—	—	68.11 (1730)	38.25 (970)
60	1500	—	—	73.03 (1855)	—

<sup>1</sup> See Figure B.6, Figure B.7, Figure B.10, and Figure B.11 for reference to dimension A, dimension B, and dimension C.

<sup>2</sup> Tolerances on standard face-to-face and end-to-end dimensions shall be ±0.06 in. (±1.5 mm) for valve sizes smaller than NPS 12 (DN 300), and ±0.12 in. (±3.0 mm) for valve sizes NPS 12 (DN 300) and larger.

**Table C.3—Check Valves and Axial Check Valves (Full Opening and Reduced Types)—Face-to-face (A) and End-to-end (B and C) Dimensions<sup>1, 2</sup>**  
(continued)

Dimensions in inches (millimeters)

NPS	DN	Long Pattern Raised Face/ Weld End <i>A/B</i>	Long Pattern Ring Joint <i>C</i>	Short Pattern Raised Face and Ring Joint <i>A/C</i>	Compact Pattern Raised Face and Ring Joint <i>A/C</i>
		Class 900			
½	15	—	—	2.17 (55)	
¾	20	9.00 (229)	9.00 (229)	2.36 (60)	
1	25	10.00 (254)	10.00 (254)	6.00 (150)	
1¼	32	11.00 (279)	11.00 (279)	6.00 (150)	
1½	40	12.00 (305)	12.00 (305)	6.70 (170)	
2	50	14.50 (368)	14.63 (371)	6.70 (170)	
2½	65	16.50 (419)	16.63 (422)	7.48 (190)	
3	80	15.00 (381)	15.13 (384)	7.48 (190)	
4	100	18.00 (457)	18.13 (460)	8.27 (210)	
6	150	24.00 (610)	24.13 (613)	9.06 (230)	
8	200	29.00 (737)	29.13 (740)	11.02 (280)	
10	250	33.00 (838)	33.13 (841)	13.78 (350)	
12	300	38.00 (965)	38.13 (968)	16.93 (430)	12.25 (310)
14	350	40.50 (1029)	40.88 (1038)	15.75 (400)	14.00 (356)
16	400	44.50 (1130)	44.88 (1140)	18.50 (470)	15.00 (384)
18	450	48.00 (1219)	48.50 (1232)	20.87 (530)	16.50 (420)
20	500	52.00 (1321)	52.50 (1334)	23.43 (595)	17.00 (430)
22	550	—	—	24.80 (630)	—
24	600	61.00 (1549)	61.75 (1568)	26.18 (665)	19.50 (495)
26	650	—	—	31.30 (795)	—
28	700	—	—	33.86 (860)	21.25 (540)
30	750	—	—	36.42 (925)	22.00 (560)
32	800	—	—	36.42 (925)	24.75 (580)
34	850	—	—	38.98 (990)	—
36	900	—	—	41.34 (1050)	27.00 (690)
38	950	—	—	44.29 (1125)	—
40	1000	—	—	46.65 (1185)	38.25 (970)
42	1050	—	—	49.21 (1250)	43.25 (1100)
48	1200	—	—	57.09 (1450)	49.25 (1250)

<sup>1</sup> See Figure B.6, Figure B.7, Figure B.10, and Figure B.11 for reference to dimension A, dimension B, and dimension C.

<sup>2</sup> Tolerances on standard face-to-face and end-to-end dimensions shall be ±0.06 in. (±1.5 mm) for valve sizes smaller than NPS 12 (DN 300), and ±0.12 in. (±3.0 mm) for valve sizes NPS 12 (DN 300) and larger.

**Table C.3—Check Valves and Axial Check Valves (Full Opening and Reduced Types)—Face-to-face (A) and End-to-end (B and C) Dimensions<sup>1, 2</sup>  
(continued)**

Dimensions in inches (millimeters)

NPS	DN	Long Pattern Raised Face / Weld End A/B	Long Pattern Ring Joint C	Short Pattern Raised Face and Ring Joint A/C	Compact Pattern Raised Face and Ring Joint A/C
		Class 1500			
½	15	8.50 (216)	8.50 (216)	2.17 (55)	
¾	20	9.00 (229)	9.00 (229)	2.36 (60)	
1	25	10.00 (254)	10.00 (254)	6.00 (150)	
1¼	32	11.00 (279)	11.00 (279)	6.00 (150)	
1½	40	12.00 (305)	12.00 (305)	6.70 (170)	
2	50	14.50 (368)	14.63 (371)	6.70 (170)	
2½	65	16.50 (419)	16.63 (422)	7.48 (190)	
3	80	18.50 (470)	18.63 (473)	8.66 (220)	
4	100	21.50 (546)	21.63 (549)	9.45 (240)	
6	150	27.75 (705)	28.00 (711)	12.20 (310)	
8	200	32.75 (832)	33.13 (841)	13.78 (350)	
10	250	39.00 (991)	39.38 (1000)	15.75 (400)	
12	300	44.50 (1130)	45.13 (1146)	17.72 (450)	—
14	350	49.50 (1257)	50.25 (1276)	19.29 (490)	—
16	400	54.50 (1384)	55.38 (1407)	20.87 (530)	—
18	450	60.50 (1537)	61.38 (1559)	22.83 (580)	—
20	500	65.50 (1664)	66.38 (1686)	25.79 (655)	—
22	550	—	—	—	—
24	600	76.50 (1943)	77.63 (1972)	29.53 (750)	—
Class 2500					
½	15	10.40 (264)	10.40 (264)	2.36 (60)	
¾	20	10.75 (273)	10.75 (273)	2.56 (65)	
1	25	12.13 (308)	12.13 (308)	6.30 (160)	
1¼	32	13.75 (349)	13.86 (352)	7.00 (180)	
1½	40	15.12 (384)	15.25 (387)	8.27 (210)	
2	50	17.75 (451)	17.88 (454)	8.27 (210)	
2½	65	20.00 (508)	20.25 (514)	9.45 (240)	
3	80	22.75 (578)	23.00 (584)	10.63 (270)	
4	100	26.50 (673)	26.88 (683)	12.20 (310)	
6	150	36.00 (914)	36.50 (927)	16.93 (430)	
8	200	40.25 (1022)	40.88 (1038)	18.11 (460)	
10	250	50.00 (1270)	50.88 (1292)	22.83 (580)	
12	300	56.00 (1422)	56.88 (1445)	22.83 (580)	—

<sup>1</sup> See Figure B.6, Figure B.7, Figure B.10, and Figure B.11 for reference to dimension A, dimension B, and dimension C.

<sup>2</sup> Tolerances on standard face-to-face and end-to-end dimensions shall be ±0.06 in. (±1.5 mm) for valve sizes smaller than NPS 12 (DN 300), and ±0.12 in. (±3.0 mm) for valve sizes NPS 12 (DN 300) and larger.

**Table C.4—Check Valves (Single- and Dual-plate, Long- and Short-pattern, Wafer-type, and Double Flanged)—Face-to-face Dimensions<sup>1,2</sup>**

Dimensions in inches (millimeters)

NPS	DN	Class 150			Class 300			Class 600		
		Short Pattern	Long Pattern	Double Flange	Short Pattern	Long Pattern	Double Flange	Short Pattern	Long Pattern	Double Flange
2	50	0.75 (19)	2.38 (60)	4.50 (114)	0.75 (19)	2.38 (60)	4.50 (114)	0.75 (19)	2.38 (60)	4.75 (121)
2½	65	0.75 (19)	2.63 (67)	— —	0.75 (19)	2.63 (67)	— —	0.75 (19)	2.63 (67)	— —
3	80	0.75 (19)	2.88 (73)	4.75 (121)	0.75 (19)	2.88 (73)	4.75 (121)	0.75 (19)	2.88 (73)	5.63 (143)
4	100	0.75 (19)	2.88 (73)	4.75 (121)	0.75 (19)	2.88 (73)	4.75 (121)	0.88 (22)	3.13 (79)	6.50 (165)
6	150	0.75 (19)	3.88 (98)	5.12 (130)	0.88 (22)	3.88 (98)	5.12 (130)	1.13 (29)	5.38 (137)	7.63 (194)
8	200	1.13 (29)	5.00 (127)	5.00 (127)	1.13 (29)	5.00 (127)	6.00 (152)	1.50 (38)	6.50 (165)	8.63 (219)
10	250	1.13 (29)	5.75 (146)	5.75 (146)	1.50 (38)	5.75 (146)	7.00 (178)	2.25 (57)	8.38 (213)	9.63 (244)
12	300	1.50 (38)	7.13 (181)	7.13 (181)	2.00 (51)	7.13 (181)	7.13 (181)	2.38 (60)	9.00 (229)	9.00 (229)
14	350	1.75 (44)	7.25 (184)	7.25 (184)	2.00 (51)	8.75 (222)	8.75 (222)	2.63 (67)	10.75 (273)	10.75 (273)
16	400	2.00 (51)	7.50 (191)	7.50 (191)	2.00 (51)	9.13 (232)	9.13 (232)	2.88 (73)	12.00 (305)	12.00 (305)
18	450	2.38 (60)	8.00 (203)	8.00 (203)	3.00 (76)	10.38 (264)	10.38 (264)	3.25 (83)	14.25 (362)	14.25 (362)
20	500	2.50 (64)	8.63 (219)	8.63 (219)	3.25 (83)	11.50 (292)	11.50 (292)	3.63 (92)	14.50 (368)	14.50 (368)
24	600	— —	8.75 (222)	8.75 (222)	— —	12.50 (318)	12.50 (318)	— —	17.25 (438)	17.25 (438)
26	650	— —	8.75 (222)	8.75 (222)	— —	12.50 (318)	12.50 (318)	— —	18.00 (457)	18.00 (457)
28	700	— —	12.00 (305)	12.00 (305)	— —	14.50 (368)	14.50 (368)	— —	19.00 (483)	19.00 (483)
30	750	— —	12.00 (305)	12.00 (305)	— —	14.50 (368)	14.50 (368)	— —	19.88 (505)	19.88 (505)
32	800	— —	14.00 (356)	14.00 (356)	— —	14.50 (368)	14.50 (368)	— —	21.00 (533)	21.00 (533)
36	900	— —	14.50 (368)	14.50 (368)	— —	19.00 (483)	19.00 (483)	— —	25.00 (635)	25.00 (635)
40	1000	— —	17.00 (432)	17.00 (432)	— —	21.50 (546)	21.50 (546)	— —	26.00 (660)	26.00 (660)
42	1050	— —	17.00 (432)	17.00 (432)	— —	22.38 (568)	22.38 (568)	— —	27.62 (702)	27.62 (702)
48	1200	— —	20.62 (524)	20.62 (524)	— —	24.75 (629)	24.75 (629)	— —	31.00 (787)	31.00 (787)
54	1350	— —	23.25 (591)	23.25 (591)	— —	28.25 (718)	28.25 (718)	— —	— —	— —
60	1500	— —	26.00 (660)	26.00 (660)	— —	33.00 (838)	33.00 (838)	— —	— —	— —

<sup>1</sup> See Figure B.8 and Figure B.9.

<sup>2</sup> Tolerances on standard face-to-face and end-to-end dimensions shall be  $\pm 0.06$  in. ( $\pm 1.5$  mm) for valve sizes smaller than NPS 12 (DN 300), and  $\pm 0.12$  in. ( $\pm 3.0$  mm) for valve sizes NPS 12 (DN 300) and larger.

**Table C.4— Check Valves (Single- and Dual-plate, Long- and Short-pattern, Wafer-type, and Double Flanged)—Face-to-face Dimensions<sup>1,2</sup> (continued)**

Dimensions in inches (millimeters)

NPS	DN	Class 900			Class 1500			Class 2500		
		Short Pattern	Long Pattern	Double Flange	Short Pattern	Long Pattern	Double Flange	Short Pattern	Long Pattern	Double Flange
2	50	0.75 (19)	2.75 (70)	6.50 (165)	0.75 (19)	2.75 (70)	6.50 (165)	— —	2.75 (70)	8.87 (225)
2½	65	0.75 (19)	3.25 (83)	— —	0.75 (19)	3.25 (83)	— —	— —	3.25 (83)	— —
3	80	0.75 (19)	3.25 (83)	6.50 (165)	0.88 (22)	3.25 (83)	8.12 (207)	— —	3.38 (86)	11.00 (280)
4	100	0.88 (22)	4.00 (102)	7.75 (197)	1.25 (32)	4.00 (102)	8.87 (225)	— —	4.13 (105)	13.00 (330)
6	150	1.38 (35)	6.25 (159)	8.63 (219)	1.75 (44)	6.25 (159)	11.37 (292)	— —	6.25 (159)	17.87 (454)
8	200	1.75 (44)	8.13 (206)	10.00 (254)	2.25 (57)	8.13 (206)	13.37 (340)	— —	8.13 (206)	19.25 (489)
10	250	2.25 (57)	9.50 (241)	10.50 (267)	2.88 (73)	9.75 (248)	15.25 (387)	— —	10.00 (254)	24.50 (622)
12	300	— —	11.50 (292)	11.50 (292)	— —	12.00 (305)	17.12 (435)	— —	12.00 (305)	27.00 (686)
14	350	— —	14.00 (356)	14.00 (356)	— —	14.00 (356)	18.75 (476)	— —	— —	— —
16	400	— —	15.13 (384)	15.13 (384)	— —	15.13 (384)	21.15 (537)	— —	— —	— —
18	450	— —	17.75 (451)	17.75 (451)	— —	18.44 (468)	22.25 (565)	— —	— —	— —
20	500	— —	17.75 (451)	17.75 (451)	— —	21.00 (533)	24.75 (629)	— —	— —	— —
24	600	— —	19.50 (495)	19.50 (495)	— —	22.00 (559)	28.87 (733)	— —	— —	— —
26	650	— —	21.00 (533)	21.00 (533)	— —	— —	— —	— —	— —	— —
28	700	— —	22.50 (572)	22.50 (572)	— —	— —	— —	— —	— —	— —
30	750	— —	25.00 (635)	25.00 (635)	— —	— —	— —	— —	— —	— —
32	800	— —	26.00 (660)	26.00 (660)	— —	— —	— —	— —	— —	— —
36	900	— —	28.25 (718)	28.25 (718)	— —	— —	— —	— —	— —	— —
40	1000	— —	30.00 (762)	30.00 (762)	— —	— —	— —	— —	— —	— —
42	1100	— —	31.00 (787)	31.00 (787)	— —	— —	— —	— —	— —	— —

<sup>1</sup> See Figure B.8 and Figure B.9.<sup>2</sup> Tolerances on standard face-to-face and end-to-end dimensions shall be  $\pm 0.06$  in. ( $\pm 1.5$  mm) for valve sizes smaller than NPS 12 (DN 300), and  $\pm 0.12$  in. ( $\pm 3.0$  mm) for valve sizes NPS 12 (DN 300) and larger.

**Table C.5—Gate Valves—Face-to-face (A) and End-to-end (B and C) Dimensions<sup>1,2</sup>**

Dimensions in inches (millimeters)

NPS	DN	Raised Face A	Weld End B	Ring Joint C	Raised Face A	Weld End B	Ring Joint C
		Class 150			Class 300		
2	50	7.00 (178)	8.50 (216)	7.50 (191)	8.50 (216)	8.50 (216)	9.13 (232)
2½	65	7.50 (191)	9.50 (241)	8.00 (203)	9.50 (241)	9.50 (241)	10.13 (257)
3	80	8.00 (203)	11.13 (283)	8.50 (216)	11.13 (283)	11.13 (283)	11.75 (298)
4	100	9.00 (229)	12.00 (305)	9.50 (241)	12.00 (305)	12.00 (305)	12.63 (321)
6	150	10.50 (267)	15.88 (403)	11.00 (279)	15.88 (403)	15.88 (403)	16.50 (419)
8	200	11.50 (292)	16.50 (419)	12.00 (305)	16.50 (419)	16.50 (419)	17.13 (435)
10	250	13.00 (330)	18.00 (457)	13.50 (343)	18.00 (457)	18.00 (457)	18.63 (473)
12	300	14.00 (356)	19.75 (502)	14.50 (368)	19.75 (502)	19.75 (502)	20.38 (518)
14	350	15.00 (381)	22.50 (572)	15.50 (394)	30.00 (762)	30.00 (762)	30.63 (778)
16	400	16.00 (406)	24.00 (610)	16.50 (419)	33.00 (838)	33.00 (838)	33.63 (854)
18	450	17.00 (432)	26.00 (660)	17.50 (445)	36.00 (914)	36.00 (914)	36.63 (930)
20	500	18.00 (457)	28.00 (711)	18.50 (470)	39.00 (991)	39.00 (991)	39.75 (1010)
22	550	—	—	—	43.00 (1092)	43.00 (1092)	43.88 (1114)
24	600	20.00 (508)	32.00 (813)	20.50 (521)	45.00 (1143)	45.00 (1143)	45.88 (1165)
26	650	22.00 (559)	34.00 (864)	—	49.00 (1245)	49.00 (1245)	50.00 (1270)
28	700	24.00 (610)	36.00 (914)	—	53.00 (1346)	53.00 (1346)	54.00 (1372)
30	750	26.00 (660)	36.00 (914)	—	55.00 (1397)	55.00 (1397)	56.00 (1422)
32	800	28.00 (711)	38.00 (965)	—	60.00 (1524)	60.00 (1524)	61.13 (1553)
34	850	30.00 (762)	40.00 (1016)	—	64.00 (1626)	64.00 (1626)	65.13 (1654)
36	900	32.00 (813)	40.00 (1016)	—	68.00 (1727)	68.00 (1727)	69.13 (1756)

<sup>1</sup> See Figure B.13 and Figure B.14 for reference to dimension A, dimension B, and dimension C.

<sup>2</sup> Tolerances on standard face-to-face and end-to-end dimensions shall be  $\pm 0.06$  in. ( $\pm 1.5$  mm) for valve sizes smaller than NPS 12 (DN 300), and  $\pm 0.12$  in. ( $\pm 3.0$  mm) for valve sizes NPS 12 (DN 300) and larger.



**Table C.5—Gate Valves—Face-to-face (A) and End-to-end (B and C) Dimensions<sup>1,2</sup> (continued)**

Dimensions in inches (millimeters)

NPS	DN	Raised Face A	Weld End B	Ring Joint C	Raised Face A	Weld End B	Ring Joint C
		Class 600			Class 900		
2	50	11.50 (292)	11.50 (292)	11.63 (295)	14.50 (368)	14.50 (368)	14.63 (371)
2 1/2	65	13.00 (330)	13.00 (330)	13.13 (333)	16.50 (419)	16.50 (419)	16.63 (422)
3	80	14.00 (356)	14.00 (356)	14.13 (359)	15.00 (381)	15.00 (381)	15.13 (384)
4	100	17.00 (432)	17.00 (432)	17.13 (435)	18.00 (457)	18.00 (457)	18.13 (460)
6	150	22.00 (559)	22.00 (559)	22.13 (562)	24.00 (610)	24.00 (610)	24.13 (613)
8	200	26.00 (660)	26.00 (660)	26.13 (664)	29.00 (737)	29.00 (737)	29.13 (740)
10	250	31.00 (787)	31.00 (787)	31.13 (791)	33.00 (838)	33.00 (838)	33.13 (841)
12	300	33.00 (838)	33.00 (838)	33.13 (841)	38.00 (965)	38.00 (965)	38.13 (968)
14	350	35.00 (889)	35.00 (889)	35.13 (892)	40.50 (1029)	40.50 (1029)	40.88 (1038)
16	400	39.00 (991)	39.00 (991)	39.13 (994)	44.50 (1130)	44.50 (1130)	44.88 (1140)
18	450	43.00 (1092)	43.00 (1092)	43.13 (1095)	48.00 (1219)	48.00 (1219)	48.50 (1232)
20	500	47.00 (1194)	47.00 (1194)	47.25 (1200)	52.00 (1321)	52.00 (1321)	52.50 (1334)
22	550	51.00 (1295)	51.00 (1295)	51.38 (1305)	—	—	—
24	600	55.00 (1397)	55.00 (1397)	55.38 (1407)	61.00 (1549)	61.00 (1549)	61.75 (1568)
26	650	57.00 (1448)	57.00 (1448)	57.50 (1461)	—	—	—
28	700	61.00 (1549)	61.00 (1549)	61.50 (1562)	—	—	—
30	750	65.00 (1651)	65.00 (1651)	65.50 (1664)	—	—	—
32	800	70.00 (1778)	70.00 (1778)	70.63 (1794)	—	—	—
34	850	76.00 (1930)	76.00 (1930)	76.63 (1946)	—	—	—
36	900	82.00 (2083)	82.00 (2083)	82.63 (2099)	—	—	—

<sup>1</sup> See Figure B.13 and Figure B.14 for reference to dimension A, dimension B, and dimension C.

<sup>2</sup> Tolerances on standard face-to-face and end-to-end dimensions shall be  $\pm 0.06$  in. ( $\pm 1.5$  mm) for valve sizes smaller than NPS 12 (DN 300), and  $\pm 0.12$  in. ( $\pm 3.0$  mm) for valve sizes NPS 12 (DN 300) and larger.

**Table C.5—Gate Valves—Face-to-face (A) and End-to-end (B and C) Dimensions<sup>1,2</sup> (continued)**

Dimensions in inches (millimeters)

NPS	DN	Raised Face A	Weld End B	Ring Joint C	Raised Face A	Weld End B	Ring Joint C
		Class 1500			Class 2500		
2	50	14.50 (368)	14.50 (368)	14.63 (371)	17.75 (451)	17.75 (451)	17.88 (454)
2½	65	16.50 (419)	16.50 (419)	16.63 (422)	20.00 (508)	20.00 (508)	20.25 (514)
3	80	18.50 (470)	18.50 (470)	18.63 (473)	22.75 (578)	22.75 (578)	23.00 (584)
4	100	21.50 (546)	21.50 (546)	21.63 (549)	26.50 (673)	26.50 (673)	26.88 (683)
6	150	27.75 (705)	27.75 (705)	28.00 (711)	36.00 (914)	36.00 (914)	36.50 (927)
8	200	32.75 (832)	32.75 (832)	33.13 (841)	40.25 (1022)	40.25 (1022)	40.88 (1038)
10	250	39.00 (991)	39.00 (991)	39.38 (1000)	50.00 (1270)	50.00 (1270)	50.88 (1292)
12	300	44.50 (1130)	44.50 (1130)	45.13 (1146)	56.00 (1422)	56.00 (1422)	56.88 (1445)
14	350	49.50 (1257)	49.50 (1257)	50.25 (1276)	—	—	—
16	400	54.50 (1384)	54.50 (1384)	55.38 (1407)	—	—	—
18	450	60.50 (1537)	60.50 (1537)	61.38 (1559)	—	—	—
20	500	65.50 (1664)	65.50 (1664)	66.38 (1686)	—	—	—
22	550	—	—	—	—	—	—
24	600	76.50 (1943)	76.50 (1943)	77.63 (1972)	—	—	—

<sup>1</sup> See Figure B.13 and Figure B.14 for reference to dimension A, dimension B, and dimension C.

<sup>2</sup> Tolerances on standard face-to-face and end-to-end dimensions shall be  $\pm 0.06$  in. ( $\pm 1.5$  mm) for valve sizes smaller than NPS 12 (DN 300), and  $\pm 0.12$  in. ( $\pm 3.0$  mm) for valve sizes NPS 12 (DN 300) and larger.

**Table C.6—Plug Valves—Face-to-face (A) and End-to-end (B and C) Dimensions<sup>1,2</sup>**

Dimensions in inches (millimeters)

NPS	DN	Short Pattern			Regular Pattern			Venturi Pattern			Round Port, Full Bore		
		Raised Face A	Weld End B	Ring Joint C	Raised Face A	Weld End B	Ring Joint C	Raised Face A	Weld End B	Ring Joint C	Raised Face A	Weld End B	Ring Joint C
<b>Class 150</b>													
2	50	7.00 (178)	10.50 (267)	7.50 (191)	—	—	—	—	—	—	10.50 (267)	—	11.00 (279)
2 <sup>1</sup> / <sub>2</sub>	65	7.50 (191)	12.00 (305)	8.00 (203)	—	—	—	—	—	—	11.75 (298)	—	12.25 (311)
3	80	8.00 (203)	13.00 (330)	8.50 (216)	—	—	—	—	—	—	13.50 (343)	—	14.00 (356)
4	100	9.00 (229)	14.00 (356)	9.50 (241)	—	—	—	—	—	—	17.00 (432)	—	17.50 (445)
6	150	10.50 (267)	18.00 (457)	11.00 (279)	15.50 (394)	—	16.00 (406)	—	—	—	21.50 (546)	—	22.00 (559)
8	200	11.50 (292)	20.50 (521)	12.00 (305)	18.00 (457)	—	18.50 (470)	—	—	—	24.50 (622)	—	25.00 (635)
10	250	13.00 (330)	22.00 (559)	13.50 (343)	21.00 (533)	—	21.50 (546)	21.00 (533)	22.00 (559)	21.50 (546)	26.00 (660)	—	26.50 (673)
12	300	14.00 (356)	25.00 (635)	14.50 (368)	24.00 (610)	—	24.50 (622)	24.00 (610)	25.00 (635)	24.50 (622)	30.00 (762)	—	30.50 (775)
14	350	—	—	—	—	—	—	27.00 (686)	27.00 (686)	27.50 (699)	—	—	—
16	400	—	—	—	—	—	—	30.00 (762)	30.00 (762)	30.50 (775)	—	—	—
18	450	—	—	—	—	—	—	34.00 (864)	34.00 (864)	34.50 (876)	—	—	—
20	500	—	—	—	—	—	—	36.00 (914)	36.00 (914)	36.50 (927)	—	—	—
24	600	—	—	—	—	—	—	42.00 (1067)	42.00 (1067)	42.50 (1080)	—	—	—

<sup>1</sup> See Figure B.15 for reference to dimension A, dimension B, and dimension C.

<sup>2</sup> Tolerances on standard face-to-face and end-to-end dimensions shall be  $\pm 0.06$  in. ( $\pm 1.5$  mm) for valve sizes smaller than NPS 12 (DN 300), and  $\pm 0.12$  in. ( $\pm 3.0$  mm) for valve sizes NPS 12 (DN 300) and larger.

**Table C.6—Plug Valves—Face-to-face (A) and End-to-end (B and C) Dimensions<sup>1, 2</sup> (continued)**

Dimensions in inches (millimeters)

NPS	DN	Short Pattern			Regular Pattern			Venturi Pattern			Round Port, Full Bore		
		Raised Face	Weld End	Ring Joint	Raised Face	Weld End	Ring Joint	Raised Face	Weld End	Ring Joint	Raised Face	Weld End	Ring Joint
		A	B	C	A	B	C	A	B	C	A	B	C
<b>Class 300</b>													
2	50	8.50 (216)	10.50 (267)	9.13 (232)	—	—	—	—	—	—	11.13 (283)	11.13 (283)	11.75 (298)
2 1/2	65	9.50 (241)	12.00 (305)	10.13 (257)	—	—	—	—	—	—	13.00 (330)	13.00 (330)	13.63 (346)
3	80	11.13 (283)	13.00 (330)	11.75 (298)	—	—	—	—	—	—	15.25 (387)	15.25 (387)	15.88 (403)
4	100	12.00 (305)	14.00 (356)	12.63 (321)	—	—	—	—	—	—	18.00 (457)	18.00 (457)	18.63 (473)
6	150	15.88 (403)	18.00 (457)	16.50 (419)	15.88 (403)	—	16.50 (419)	15.88 (403)	18.00 (457)	16.50 (419)	22.00 (559)	22.00 (559)	22.63 (575)
8	200	16.50 (419)	20.50 (521)	17.13 (435)	19.75 (502)	—	20.38 (518)	16.50 (419)	20.50 (521)	17.13 (435)	27.00 (686)	27.00 (686)	27.63 (702)
10	250	18.00 (457)	22.00 (559)	18.63 (473)	22.38 (568)	—	23.00 (584)	18.00 (457)	22.00 (559)	18.63 (473)	32.50 (826)	32.50 (826)	33.13 (841)
12	300	19.75 (502)	25.00 (635)	20.38 (518)	—	—	—	19.75 (502)	25.00 (635)	20.38 (518)	38.00 (965)	38.00 (965)	38.63 (981)
14	350	—	—	—	—	—	—	30.00 (762)	30.00 (762)	30.63 (778)	—	—	—
16	400	—	—	—	—	—	—	33.00 (838)	33.00 (838)	33.63 (854)	—	—	—
18	450	—	—	—	36.00 (914)	—	36.63 (930)	36.00 (914)	36.00 (914)	36.63 (930)	—	—	—
20	500	—	—	—	39.00 (991)	—	39.75 (1010)	39.00 (991)	39.00 (991)	39.75 (1010)	—	—	—
22	550	—	—	—	43.00 (1092)	—	43.88 (1114)	43.00 (1092)	43.00 (1092)	43.88 (1114)	—	—	—
24	600	—	—	—	45.00 (1143)	—	45.88 (1165)	45.00 (1143)	45.00 (1143)	45.88 (1165)	—	—	—
26	650	—	—	—	49.00 (1245)	—	50.00 (1270)	49.00 (1245)	49.00 (1245)	50.00 (1270)	—	—	—
28	700	—	—	—	53.00 (1346)	—	54.00 (1372)	53.00 (1346)	53.00 (1346)	54.00 (1372)	—	—	—
30	750	—	—	—	55.00 (1397)	—	56.00 (1422)	55.00 (1397)	55.00 (1397)	56.00 (1422)	—	—	—
32	800	—	—	—	60.00 (1524)	—	61.13 (1553)	60.00 (1524)	60.00 (1524)	61.13 (1553)	—	—	—
34	850	—	—	—	64.00 (1626)	—	65.13 (1654)	64.00 (1626)	64.00 (1626)	65.13 (1654)	—	—	—
36	900	—	—	—	68.00 (1727)	—	69.13 (1756)	68.00 (1727)	68.00 (1727)	69.13 (1756)	—	—	—

<sup>1</sup> See Figure B.15 for reference to dimension A, dimension B, and dimension C.<sup>2</sup> Tolerances on standard face-to-face and end-to-end dimensions shall be  $\pm 0.06$  in. ( $\pm 1.5$  mm) for valve sizes smaller than NPS 12 (DN 300), and  $\pm 0.12$  in. ( $\pm 3.0$  mm) for valve sizes NPS 12 (DN 300) and larger.

**Table C.6—Plug Valves—Face-to-face (A) and End-to-end (B and C) Dimensions<sup>1,2</sup> (continued)**

Dimensions in inches (millimeters)

NPS	DN	Regular Pattern			Venturi Pattern			Round Port, Full Bore		
		Raised Face A	Weld End B	Ring Joint C	Raised Face A	Weld End B	Ring Joint C	Raised Face A	Weld End B	Ring Joint C
		Class 600								
2	50	11.50 (292)	11.50 (292)	11.63 (295)	—	—	—	13.00 (330)	—	13.13 (333)
2 1/2	65	13.00 (330)	13.00 (330)	13.13 (333)	—	—	—	15.00 (381)	—	15.13 (384)
3	80	14.00 (356)	14.00 (356)	14.13 (359)	—	—	—	17.50 (445)	—	17.63 (448)
4	100	17.00 (432)	17.00 (432)	17.13 (435)	—	—	—	20.00 (508)	22.00 (559)	20.13 (511)
6	150	22.00 (559)	22.00 (559)	22.13 (562)	22.00 (559)	22.00 (559)	22.13 (562)	26.00 (660)	28.00 (711)	26.13 (664)
8	200	26.00 (660)	26.00 (660)	26.13 (664)	26.00 (660)	26.00 (660)	26.13 (664)	31.25 (794)	33.25 (845)	31.38 (797)
10	250	31.00 (787)	31.00 (787)	31.13 (791)	31.00 (787)	31.00 (787)	31.13 (791)	37.00 (940)	40.00 (1016)	37.13 (943)
12	300	—	—	—	33.00 (838)	33.00 (838)	33.13 (841)	42.00 (1067)	42.00 (1067)	42.13 (1070)
14	350	—	—	—	35.00 (889)	35.00 (889)	35.13 (892)	—	—	—
16	400	—	—	—	39.00 (991)	39.00 (991)	39.13 (994)	—	—	—
18	450	—	—	—	43.00 (1092)	43.00 (1092)	43.13 (1095)	—	—	—
20	500	—	—	—	47.00 (1194)	47.00 (1194)	47.25 (1200)	—	—	—
22	550	—	—	—	51.00 (1295)	51.00 (1295)	51.38 (1305)	—	—	—
24	600	—	—	—	55.00 (1397)	55.00 (1397)	55.38 (1407)	—	—	—
26	650	—	—	—	57.00 (1448)	57.00 (1448)	57.50 (1461)	—	—	—
30	750	—	—	—	65.00 (1651)	65.00 (1651)	65.50 (1664)	—	—	—
32	800	—	—	—	70.00 (1778)	70.00 (1778)	70.63 (1794)	—	—	—
34	850	—	—	—	76.00 (1930)	76.00 (1930)	76.63 (1946)	—	—	—
36	900	—	—	—	82.00 (2083)	82.00 (2083)	82.63 (2099)	—	—	—

<sup>1</sup> See Figure B.15 for reference to dimension A, dimension B, and dimension C.

<sup>2</sup> Tolerances on standard face-to-face and end-to-end dimensions shall be  $\pm 0.06$  in. ( $\pm 1.5$  mm) for valve sizes smaller than NPS 12 (DN 300), and  $\pm 0.12$  in. ( $\pm 3.0$  mm) for valve sizes NPS 12 (DN 300) and larger.

Table C.6—Plug Valves—Face-to-face (A) and End-to-end (B and C) Dimensions<sup>1,2</sup> (Continued)

Dimensions in inches (millimeters)

NPS	DN	Regular Pattern			Venturi Pattern			Round Port, Full Bore		
		Raised Face A	Weld End B	Ring Joint C	Raised Face A	Weld End B	Ring Joint C	Raised Face A	Weld End B	Ring Joint C
		Class 900								
2	50	14.50 (368)	—	14.63 (371)	—	—	—	15.00 (381)	—	15.13 (384)
2 1/2	65	16.50 (419)	—	16.63 (422)	—	—	—	17.00 (432)	—	17.13 (435)
3	80	15.00 (381)	15.00 (381)	15.13 (384)	—	—	—	18.50 (470)	—	18.63 (473)
4	100	18.00 (457)	18.00 (457)	18.13 (460)	—	—	—	22.00 (559)	—	22.13 (562)
6	150	24.00 (610)	24.00 (610)	24.13 (613)	24.00 (610)	24.00 (610)	24.13 (613)	29.00 (737)	—	29.13 (740)
8	200	29.00 (737)	29.00 (737)	29.13 (740)	29.00 (737)	29.00 (737)	29.13 (740)	32.00 (813)	—	32.13 (816)
10	250	33.00 (838)	33.00 (838)	33.13 (841)	33.00 (838)	33.00 (838)	33.13 (841)	38.00 (965)	—	38.13 (968)
12	300	—	—	—	38.00 (965)	38.00 (965)	38.13 (968)	44.00 (1118)	—	44.13 (1121)
16	400	—	—	—	44.50 (1130)	44.50 (1130)	44.88 (1140)	—	—	—

<sup>1</sup> See Figure B.15 for reference to dimension A, dimension B, and dimension C.

<sup>2</sup> Tolerances on standard face-to-face and end-to-end dimensions shall be  $\pm 0.06$  in. ( $\pm 1.5$  mm) for valve sizes smaller than NPS 12 (DN 300), and  $\pm 0.12$  in. ( $\pm 3.0$  mm) for valve sizes NPS 12 (DN 300) and larger.

**Table C.6—Plug Valves—Face-to-face (A) and End-to-end (B and C) Dimensions<sup>1,2</sup> (continued)**

Dimensions in inches (millimeters)

NPS	DN	Regular Pattern			Venturi Pattern			Round Port, Full Bore		
		Raised Face A	Weld End B	Ring Joint C	Raised Face A	Weld End B	Ring Joint C	Raised Face A	Weld End B	Ring Joint C
		Class 1500								
2	50	14.50 (368)	—	14.63 (371)	—	—	—	15.38 (391)	—	15.50 (394)
2 <sup>1/2</sup>	65	16.50 (419)	—	16.63 (422)	—	—	—	17.88 (454)	—	18.00 (457)
3	80	18.50 (470)	18.50 (470)	18.63 (473)	—	—	—	20.63 (524)	—	20.75 (527)
4	100	21.50 (546)	21.50 (546)	21.63 (549)	—	—	—	24.63 (625)	—	24.75 (629)
6	150	27.75 (705)	27.75 (705)	28.00 (711)	27.75 (705)	27.75 (705)	28.00 (711)	31.00 (787)	—	31.25 (794)
8	200	32.75 (832)	32.75 (832)	33.13 (841)	32.75 (832)	32.75 (832)	33.13 (841)	35.00 (889)	—	35.38 (899)
10	250	39.00 (991)	39.00 (991)	39.38 (1000)	39.00 (991)	39.00 (991)	39.38 (1000)	42.00 (1067)	—	42.38 (1076)
12	300	44.50 (1130)	44.50 (1130)	45.13 (1146)	44.50 (1130)	44.50 (1130)	45.13 (1146)	48.00 (1219)	—	48.63 (1235)
Class 2500										
2	50	17.75 (451)	—	17.88 (454)	—	—	—	—	—	—
2 <sup>1/2</sup>	65	20.00 (508)	—	20.25 (514)	—	—	—	—	—	—
3	80	22.75 (578)	—	23.00 (584)	—	—	—	—	—	—
4	100	26.50 (673)	—	26.88 (683)	—	—	—	—	—	—
6	150	36.00 (914)	—	36.50 (927)	—	—	—	—	—	—
8	200	40.25 (1022)	—	40.88 (1038)	—	—	—	—	—	—
10	250	50.00 (1270)	—	50.88 (1292)	—	—	—	—	—	—
12	300	56.00 (1422)	—	56.88 (1445)	—	—	—	—	—	—

<sup>1</sup> See Figure B.15 for reference to dimension A, dimension B, and dimension C,<sup>2</sup> Tolerances on standard face-to-face and end-to-end dimensions shall be  $\pm 0.06$  in. ( $\pm 1.5$  mm) for valve sizes smaller than NPS 12 (DN 300), and  $\pm 0.12$  in. ( $\pm 3.0$  mm) for valve sizes NPS 12 (DN 300) and larger.

*This document is not an API Standard; it is under consideration within an API technical committee but has not received all approvals required to become an API Standard. It shall not be reproduced or circulated or quoted, in whole or in part, outside of API committee activities except with the approval of the Chairman of the committee having jurisdiction and staff of the API Standards Dept. Copyright API. All rights reserved.*

## Annex D (informative)

### Guidance for Travel Stops by Valve Type

Table D.1 provides guidance on travel stops by common valve type.

**Table D.1—Valve Travel Stops**

Valve Type	Option/Detail	Travel Stop Requirements	Manual Gearbox	Actuator <sup>9</sup>
Quarter-turn ball	All	Stops for open and closed	Stops in gearbox for open and close	Actuator controls position, not valve stops
Rising stem ball	All	Stops for open position only	Stops in gearbox for open position	Actuator controls position for open
Check	With external clapper lift	Stop in body required for open No stop required for closed	Gearbox stops in open and closed position to avoid overloading valve shaft in the open position and over-rotating the shaft past the closed position	Actuator controls open position, not valve stop, to avoid overloading valve shaft
Gate— slab/parallel through-conduit	Conventional (down to closed), no backseat.	Stops for open and closed	Stops in valve for open or closed <sup>a f</sup>	Actuator controls position, not valve stops
	Conventional (down to closed), with backseat.	Stops for open and closed	Stops for open and close in valve <sup>a c f</sup>	Actuator torque/thrust adjusted or selected to suit backseat in open
	Reverse acting (up to closed), no backseat.	Stops for open and closed	Stops for open and closed in valve <sup>a</sup>	Actuator controls position, not valve stops
	Reverse acting (up to closed), with backseat.	Stops for open and closed <sup>b</sup>	Stops for open and closed in valve <sup>a,b</sup>	Actuator controls position for open. Actuator torque/thrust adjusted or selected to suit backseat in closed position
Gate—expanding	Conventional, single expanding with backseat	No stops required <sup>c, d</sup>	Stops for open in valve <sup>c</sup> Gearbox stop not required	Actuator torque/thrust adjusted or selected to suit closing load in closed and backseat in open
	Conventional, single expanding without backseat	No stops required for closed <sup>d</sup> Stop in valve required for open	Stops for open in valve Gearbox stop not required	Actuator torque/thrust adjusted or selected to suit closing load in closed
	Conventional, double, or expanding without backseat	No stops required <sup>e</sup>	Gearbox stop not required	Actuator torque/thrust adjusted or selected to suit closing load in closed and wedging load in open
Plug—non-expanding	All	Stops for open and closed	Stops for open and closed in gearbox	Actuator controls position, not valve stops
Plug—expanding	Conventional, double expanding	No stops required in closed Stop in valve required in open	Stops for open in gearbox No stop required in closed	Stop for open Actuator torque/thrust selected to adjust closing load in closed



- <sup>a</sup> Open stops may be in yoke or on stem.
- <sup>b</sup> Backseat provides closed stop.
- <sup>c</sup> Backseat provides open stop.
- <sup>d</sup> Wedging action provides closed stop.
- <sup>e</sup> Wedging action provides closed and open stop.
- <sup>f</sup> Closed stops may be in yoke or on stem.
- <sup>g</sup> See API 6DX for guidance on actuator control for valve stops.

*This document is not an API Standard; it is under consideration within an API technical committee but has not received all approvals required to become an API Standard. It shall not be reproduced or circulated or quoted, in whole or in part, outside of API committee activities except with the approval of the Chairman of the committee having jurisdiction and staff of the API Standards Dept. Copyright API. All rights reserved.*

## Annex E (informative)

### Isolation Valve Features

#### E.1 Application of this Annex

Table E.1 is intended to give informative guidance on typical valve functions/features and is not intended to either be all-inclusive or restrictive. Individual valve designs exist that have unique sealing characteristics for which the table may not be appropriate or applicable. The user should take guidance from the manufacturer on establishing specific valve features.

**Table E.1—Isolation Valve Types**

Valve Type	Sealing Arrangement	Block and Bleed	Double Block and Bleed	Double Isolation and Bleed
<b>General:</b> Single valve with two or more closure members	Any valves with bidirectional sealing	Yes	Yes	Yes
<b>Ball:</b>				
Trunnion mounted valve	Upstream sealing, pressure energized, self-relieving (Note 1)	Yes	(Note 4)	No (Note 5)
Trunnion mounted valve DIB-1	Upstream and downstream sealing, pressure energized, e.g., two bidirectional sealing seats (Note 1)	Yes	(Note 4)	(Note 6)
Trunnion mounted valve DIB-2	Upstream and downstream sealing, pressure energized, e.g., one bidirectional and one unidirectional sealing seat (Note 1)	Yes	(Note 4)	Only if bidirectional seat is on downstream side (Note 6)
Floating valve	Pressure energized	(Note 2) (Note 4)	(Note 4)	(Note 4)
<b>Gate:</b>				
Slab and/or through-conduit	Pressure energized—downstream sealing only/fixed seats (Note 1)	No (Note 2)	No	No
Slab and/or through-conduit DIB-1	Pressure energized—upstream and downstream sealing (Note 1)	Yes	Yes (Note 3)	Yes (Note 3)
Expanding DIB-1	Mechanically energized	Yes	Yes (Note 3)	Yes (Note 3)
<b>Plug:</b>				
Standard	Pressure energized, downstream sealing	No (Note 2)	No	No
Expanding DIB-1	Mechanically energized	Yes	Yes	Yes

- <sup>1</sup> The terms “upstream” and “downstream” refer to the pressure source and open end/equipment, respectively, and do not refer to flow direction.
- <sup>2</sup> Not possible to bleed from valve body, but bleed may be in downstream pipework/pipeline.
- <sup>3</sup> Depending on detail design of the valve, some valves may have preferred sealing direction and/or a specified sequence of operation.
- <sup>4</sup> Depending on detailed design.
- <sup>5</sup> Downstream seat may provide a second barrier at pressures below the cavity relieving pressure barrier.
- <sup>6</sup> Depending on detailed design and ability to achieve testing per L.10 or L.11.

## E.2 Description of Sketches

The user is responsible for ensuring the operational requirements are consistent with specific valve features, including sealing capability and function.

The table and sketches are typical and intended to give definition of the terms for specific valve types defined in E.3 through E.5. Other documents, including applicable federal regulations, may have a different definition of these terms.

## E.3 Block and Bleed (BB)

BB may be achieved by a connection in the pipework/pipeline downstream of the block valve or from a connection on the valve body when the valve is an upstream seating type. See Figure E.1 and Figure E.2.

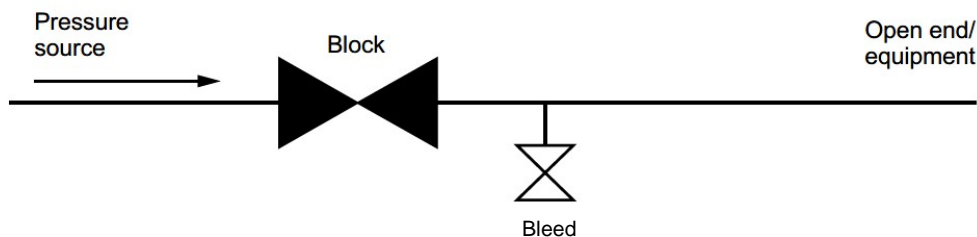


Figure E.1—Block and Bleed—Type A

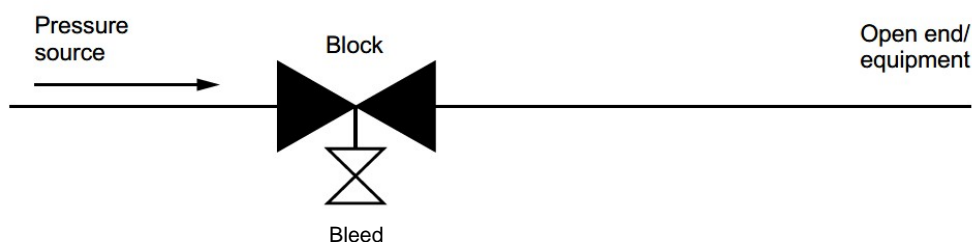
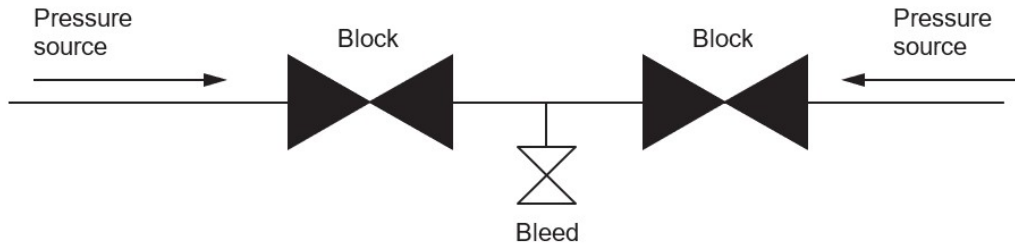


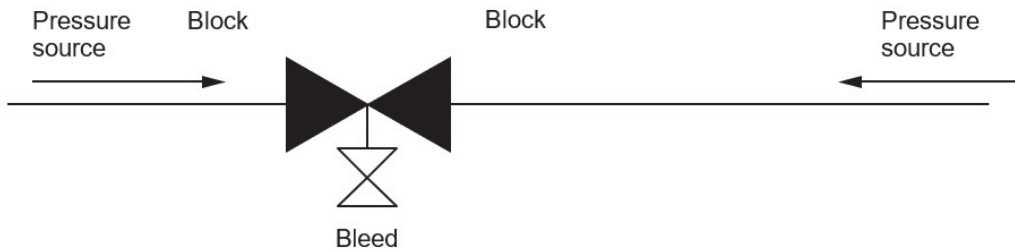
Figure E.2—Block and Bleed—Type B

## E.4 Double Block and Bleed (DBB)

The DBB feature of the valve or valves is the ability to segregate two pressure sources and to bleed/vent pressure in the void between the two sealing elements (blocks). The bleed may be in the pipework/pipeline when two valves are used, or in the valve body between the two seats when the valve has the DBB feature. See Figure E.3 and Figure E.4.



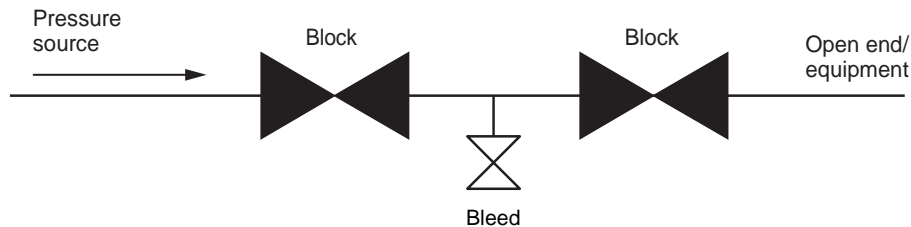
**Figure E.3—Double Block and Bleed—Type A**



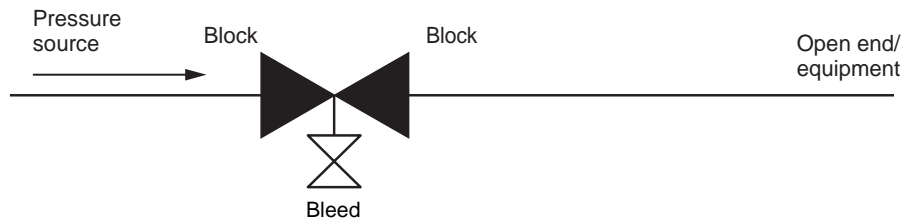
**Figure E.4—Double Block and Bleed—Type B**

## E.5 Double Isolation and Bleed (DIB)

The DIB feature of the valve or valves is the ability to provide two sealing elements to a single pressure source, and to bleed/vent between the two sealing elements. Note that some documents dealing with isolation of equipment may refer to this feature as double block and bleed. See Figure E.5 and Figure E.6.



**Figure E.5—Double Isolation and Bleed—Type A**



**Figure E.6—Double Isolation and Bleed—Type B**

## **Annex F** **(informative)**

### **Design Validation**

#### **F.1 General**

This annex provides one method of design validation procedures for equipment identified in this specification, which shall be applied if specified by the manufacturer or purchaser.

When this annex is applied, the design validation procedures in this annex shall be applied to the designs of products, including design changes. It is intended that this annex shall not apply to validation of components and or parts.

#### **F.2 Effect of Changes in Product**

A change in one of the following parameters shall require a new design validation:

- valve type;
- valve configuration;
- body style (e.g., two-piece versus three-piece, top entry versus side entry);
- type of sealing element (e.g., O-ring, lip-seals, chevrons, BX ring, RTJ);
- seat design and seat insert material;
- design criteria on pressure-containing parts, including pressure boundary bolting;
- design criteria of closure member and seats;
- design of seal mating parts;
- design criteria of seat/closure member interfaces;
- design criteria of the drive train;
- maximum speed of operation (e.g., a valve qualified for a 10-second operation would qualify all slower operating times).

Other changes (such as supplier of sealing element) shall not require new design validation if the manufacturer demonstrates that the performance of the product in the intended pressure, temperature, and service condition shall be maintained.

If a valve with DPE seats or with self-relieving seats has been previously validated, using a combination of DPE and self-relieving seats shall not need further validation.

## **F.3 Products for Design Validation**

### **F.3.1 General**

Design validation shall be performed on fully assembled valves.

Prior to performing any gas testing, the valve shall have successfully passed the body hydrostatic testing per F.17.1.

Prototype valves shall be manufactured to the same manufacturing methods and control used to manufacture production valves.

Valves or components that have undergone validation may be used for further testing or in a production unit.

If the valve is to be reassembled and used as a production valve after design validation is performed, the following minimum activities shall apply:

- all seals replaced;
- bearings and thrust washers replaced;
- seat springs replaced;
- dimensional inspection on pressure-containing and pressure-controlling parts and pressure-boundary bolting performed to verify continued conformance with the manufacturer's drawing dimensions and design acceptance criteria;
- sealing surface finishes on pressure-containing and pressure-controlling parts checked to verify continued conformance with the design acceptance criteria;
- nonconforming parts reworked or replaced;
- for reworked components, the manufacturer shall demonstrate that the rework does not affect any of the elements or parameters listed in F.2;
- reapply the same surface NDE already applied on the finished machined parts; and
- FAT/production testing is performed in accordance with Section 10.

### **F.3.2 Test Valve**

For products that are provided with multiple sealing sets, each seal set shall be independently verified at the beginning, at the minimum and maximum temperatures, and at the end of the design validation procedure.

Valves shall be tested with end caps or blind flanges fitted.

NOTE A chevron packing stack is considered to be a single sealing set.

## **F.4 External Paint or Coatings**

The product used in validation shall be free of paint or other coatings.

## **F.5 Safety**

The manufacturer shall identify and implement the actions needed to provide for the safety of personnel and equipment.

## **F.6 Test Orientation**

Validation shall be performed with the stem in vertical orientation with the horizontal bore, unless otherwise agreed.

Different installation between the prototype and production valve shall not require a new validation if the suitability of the orientation can be substantiated by other means.

## **F.7 Testing Medium**

### **F.7.1 General**

The testing medium shall be a fluid that remains in the liquid or gaseous state throughout the testing temperature range. Water with or without additives, gas, hydraulic fluid, or other mixtures of fluids may be used as the test medium.

### **F.7.2 Substitution of Gas**

The manufacturer may substitute gas for liquid if hydrostatic testing is specified, provided the testing method and acceptance criteria for gas testing are used.

## **F.8 Temperature Testing**

### **F.8.1 Location of Temperature Measurement**

The temperature shall be measured using one of the following methods:

Method 1—In contact with the external surface on two locations at a minimum:

- in the seat area; and
- on the bonnet adjacent to the stem seal.

Method 2—In contact with the equipment being tested and within 0.5 in. (13 mm) of the surface wetted by the retained fluid.

Method 3—For maximum-temperature measurement only, the temperature of the fluid used for heating can be employed if the part is not artificially cooled.

### **F.8.2 Application of Cooling for Minimum Temperature Testing**

The cooling for minimum temperature testing shall be applied on the external surface of the equipment and/or through the valve bore, per the manufacturer's design criteria.

## **F.9 Test Duration**

### **F.9.1 Start of Test Duration**

Test duration shall start after pressure and temperature stabilization has occurred and the equipment with a pressure-monitoring device has been isolated from the pressure source. The specified test duration shall be considered a minimum requirement.

### **F.9.2 Pressure Stabilization**

The stabilization criteria shall be documented in the manufacturer's pressure testing procedure.

### **F.9.3 Pressure Maintenance**

Pressure shall not vary by more than 10 % during the test duration.

Pressure shall not fall below the test pressure before the end of the test duration.

### **F.9.4 Temperature Stabilization**

The temperature shall be recognized as stabilized when the rate of change is less than 1 °F/min (0.5 °C/min).

The temperature shall remain at or beyond the extreme during the test duration, but should not go beyond the upper and lower temperatures by more than 20 °F (11 °C).

## **F.10 Scaling**

### **F.10.1 General**

Design validation of a valve shall be independent of the type of actuation used during the validation.

**NOTE** Scaling may be used to validate members of a product family in conformance with the requirement of this paragraph.

### **F.10.2 Product Family**

A product family shall meet the following design criteria:

- All parameters listed in F.2 are the same.
- Principles of functional operation are the same (e.g., non-return, linear, quarter-turn, etc.).
- Design requirements are the same, resulting in a comparable safety factor in relation to material properties.

**NOTE** If finite element analysis (FEA) is available, the design stress levels in relation to material mechanical properties may be based on these same criteria.

## **F.11 Limitations of Scaling**

### **F.11.1 General Design Validation**

Testing a valve with any type of end connector shall validate the same valve with any other end connector type.



NOTE Validation testing of this annex is for valve designs; validation of end connectors is outside the scope.

A bolted bonnet valve qualifies a welded bonnet valve.

### **F.11.2 Design Validation by Pressure Rating**

Product family validation range is as follows:

- ASME Class 150 validates only Class 150.
- ASME Class 300 validates Class 300 and Class 150.
- ASME Class 600 validates Class 600, Class 300, and Class 150.
- ASME Class 900 validates only Class 900.
- ASME Class 1500 validates Class 1500 and Class 900.
- ASME Class 2500 validates only Class 2500.

Intermediate rated valves shall be validated by itself or the next higher Class rated valve.

### **F.11.3 Design Validation by Size**

For circular opening valves, the size used for the scaling criteria described in F.11.3 shall be the bore size of the closure member.

For noncircular opening valves, the size used for the scaling criteria described in F.11.3 shall be the nominal size of the end connector.

The tested valve shall qualify the following:

Valves ranging in size from NPS ½ (DN 15) up to and including NPS 2 (DN 50) shall qualify the full range, e.g., a successful testing of a NPS 1 (DN 25) valve size qualifies NPS ½ (DN 15) through to NPS 2 (DN 50).

Sizes from NPS 3 (DN80) up to NPS 24 (DN600) shall qualify nominal valve sizes three sizes smaller and two sizes larger.

Sizes above NPS 24 (DN600) shall qualify nominal valve sizes one size smaller and two sizes larger.

### **F.11.4 Design Validation by Temperature**

The temperature range validated by the tested valve shall validate all temperatures that fall entirely within that range.

## **F.12 Documentation**

### **F.12.1 Design Validation Files**

The manufacturer shall maintain a file on each design validation.

### **F.12.2 Contents of Design Validation Files**

Design validation files shall contain or reference the following information:

- a) test number and revision level, or test procedure;
- b) complete identification of the product being tested;
- c) date of test completion;
- d) test results and post-test examination conclusions (see F.16);
- e) model numbers and other pertinent identifying data on all other sizes, rated pressure-temperature ranges, and standard test fluid ratings of products of the same product family that are validated by the validation of this specific product;
- f) detailed dimensional drawings and material specifications applicable to the tested product, including seals and non-extrusion devices;
- g) sketch of test rig, product, and seal or sample, temperature and pressure measurement locations;
- h) sealing-surface dimensions;
- i) test data specified in this annex, including actual test conditions (pressure, temperature, etc.) and observed leakages or other acceptance parameters, and identification of testing media used;
- j) test equipment identification and calibration status;
- k) certification of manufacturer report, including the supplier of test seals.

### **F.13 Test Equipment Calibration Requirements**

Measuring and test equipment shall be identified, controlled, calibrated, and adjusted as per 9.1.

### **F.14 Design Validation Procedure**

The procedure to validate a valve design shall be as identified in Table F.1.

For valves with two unidirectional seats, each seat shall be tested in accordance with 10.4.3.1.

For valves with two bidirectional seats, the upstream seat shall be tested per L.10 with half the cycles in F.19 and F.20, and the downstream seat shall be tested per L.10 with half the cycles in F.19 and F.20.

For valves with one seat unidirectional and one seat bidirectional, the unidirectional seat shall be tested per 10.4.3.1 with half the cycles in F.19 and F.20 and the bidirectional seat shall be tested per L.11 with half the cycles in F.19 and F.20.

### **F.15 Structural Integrity**

Product that deforms to an extent that any other performance requirement cannot be achieved shall be considered not acceptable and the product shall be rejected (see F.16).

### **F.16 Post-test Examination**

The tested prototype shall be disassembled and inspected, and all critical parts shall be photographed.

The examination shall be performed to ensure that neither the product nor the component design contains defects to the extent that any performance requirement cannot be met. The results of the examination shall be documented.

**Table F.1—Design Validation for Valves**

<b>Design Validation</b>	<b>Reference Section</b>
Hydrostatic body pressure test	F.17.1
Hydrostatic seat pressure test	F.17.2
Force or torque measurement (initial test)	F.18
Dynamic (open/close cycling) pressure test at ambient temperature	160 cycles per F.19
Dynamic (open/close cycling) pressure gas test at maximum temperature	20 cycles per F.20
Gas body test at maximum rated temperature	F.21
Gas seat test at maximum rated temperature	F.22
Low-pressure seat test at maximum rated temperature	F.23
Dynamic (open/close cycling) pressure gas test at minimum temperature	20 cycles per F.20
Gas body test at minimum rated temperature	F.21
Gas seat test at minimum rated temperature	F.22
Low-pressure gas seat test at minimum rated temperature	F.23
Gas body shell gas pressure and temperature cycling	F.24
Gas body test at ambient temperature	F.25
High-pressure gas seat test at ambient temperature	F.26
Low-pressure gas seat test at ambient temperature	F.27
Final force or torque measurement (final test)	F.18
Post-test examination	F.16

## **F.17 Pressure Testing at Ambient Temperature**

### **F.17.1 Hydrostatic Body Pressure Test**

Hydrostatic body testing shall conform to 10.3.

Test duration shall be a minimum of 1 hour.

### **F.17.2 Hydrostatic Seat Pressure Test**

Hydrostatic seat testing shall conform to 10.4.

Test duration shall be a minimum of 1 hour.

When a valve is provided with self-relieving function, a test according to I.7 shall be performed.

## **F.18 Force or Torque Measurement**

The breakaway and running torques or forces shall be measured at the MAWP.

This shall be applicable to all valves, including check valves provided with an external operator if no differential pressure is applied across the closure member.

NOTE The force/torque may be determined by direct or indirect measurement (i.e., pressure applied to an area).

The manufacturer shall prepare a procedure to measure breakaway and running torques or forces.

The operating forces or torques shall be within the manufacturer's specifications.

## F.19 Dynamic (Open/Close Cycling) Pressure Test at Ambient Temperature

### F.19.1 Speed of Operation

The speed of operation shall be recorded.

### F.19.2 Procedure for Valves Except Check Valves

The valves shall be tested as follows:

- a) Fill the downstream end of the valve with the test medium at 1 % or less of test pressure.
- b) Apply pressure equal to the ambient working pressure against the upstream side of the valve. All subsequent seat tests shall be as specified in F.14.
- c) Open the valve fully, starting against the full differential pressure. Pressure shall be maintained at the percentage of the initial test pressure after the BTO as per Table F.2.

NOTE The opening stroke may be interrupted to adjust the pressure within the above limits of Table F.2.

**Table F.2—Minimum Percentage of Pressure During Opening Phase**

Valve Type	Minimum Percentage of Initial Pressure
Rising stem valves	50 %
All other valve types	30 %

- d) Close the valve fully while pressure is maintained within the limits of the preceding step.
- e) Bleed the downstream pressure to 1 % or less of test pressure after the valve is fully closed.
- f) Repeat until a minimum of 160 pressure cycles has been carried out.

### F.19.3 Procedure for Check Valves

The manufacturer shall maintain a documented procedure for check valve testing.

Check valves shall be tested as follows:

- a) Apply pressure equal to the ambient working pressure to the downstream side of the valve.
- b) Relieve the pressure on the downstream side and apply 1 % or less of test pressure on the upstream side, and unseat the valve.
- c) Repeat until a minimum of 160 pressure cycles have been carried out.

For check valves provided with an external operator, 160 opening/closing cycles shall be performed on the external operator without differential pressure across the closure member.

## **F.20 Dynamic (Open/Close Cycling) Pressure Gas Test at Maximum/Minimum Rated Temperature**

At the maximum/minimum allowable temperature, the procedure of F.19 shall be followed with the exception that the number of cycles shall be 20 and the test medium shall be gas.

## **F.21 Gas Body Test at Maximum/Minimum Rated Temperature**

The gas body test shall be performed as follows:

- a) The valves shall be in the partially open position during testing. Check valves shall be tested from the upstream side.
- b) The test pressure shall be the maximum rating pressure at test temperature.
- c) The test duration shall be 1 hour.

A gas body test at maximum/minimum temperature shall be acceptable if the pressure change observed on the pressure-measuring device is less than 5 % of the test pressure or 500 psi (3.45 MPa), whichever is less.

## **F.22 Gas Seat Test at Maximum/Minimum Rated Temperature**

The maximum rating pressure at test temperature shall be applied on the upstream side of the valves and released on the downstream side. Check valves shall be tested from the downstream side.

The test duration shall be a minimum of 1 hour.

The pressure shall be released after the test duration.

A gas seat test at maximum/minimum temperature shall be acceptable if the leakage rate is less than the acceptance criteria specified in F.26.

## **F.23 Low-pressure Gas Seat Test at Maximum/Minimum Rated Temperature**

The valves shall be subjected to a differential pressure between 5 % and no more than 10 % of the rated working pressure, with a minimum of 80 psi (5.5 bar). The pressure shall be applied on the upstream side of the valves and released on the downstream side. For check valves, the low-pressure seat test pressure shall be applied on the downstream end of the valve, with the opposite end vented to the atmosphere.

The test duration shall be a minimum of 1 hour.

A gas seat test at maximum/minimum temperature shall be acceptable if the leakage rate is less than the acceptance criteria specified in F.27.

## **F.24 Gas Body Shell Pressure and Temperature Cycling**

### **F.24.1 General**

Pressure/temperature cycles of the body shell shall be performed as specified in Figure F.1.

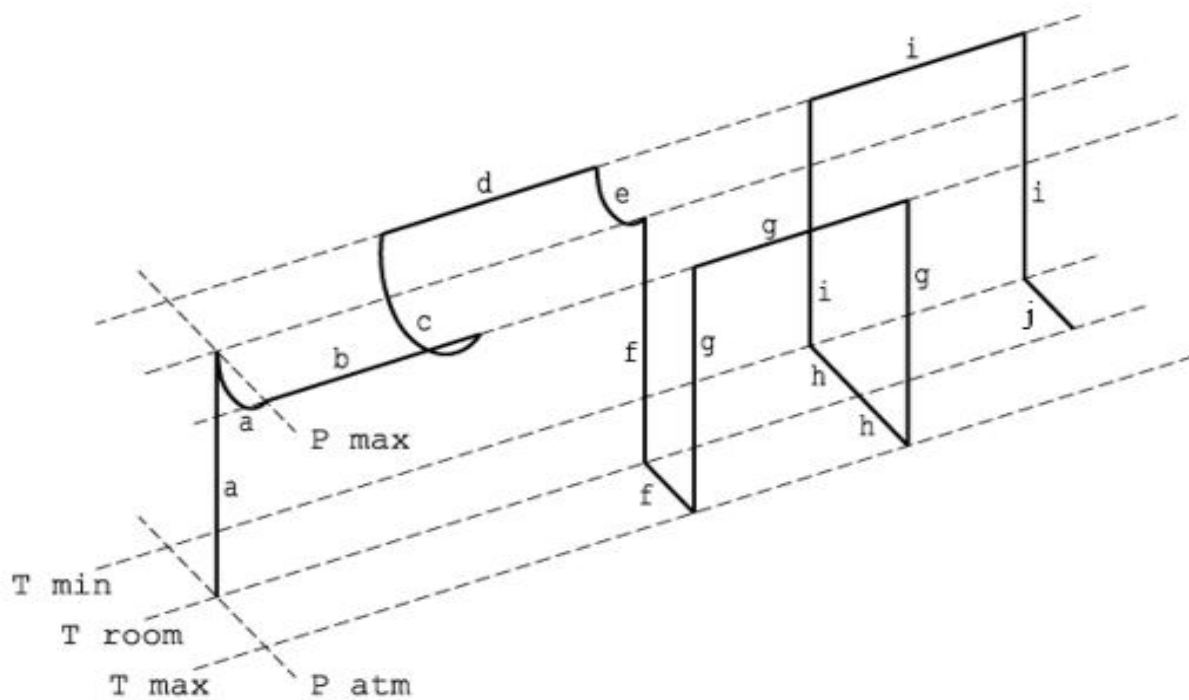


Figure F.1—Test Procedure for Pressure Temperature Cycle

### F.24.2 Test Pressure and Temperature

The test pressure and temperature extremes shall be as specified in a validation procedure.

### F.24.3 Test Procedure

Pressure shall be monitored and controlled during temperature change. The following procedure shall be performed.

NOTE The item letters of the steps of the procedure correspond to the letters shown in Figure F.1.

- a) Apply the test pressure to the body shell at ambient temperature and maintain at 50 % to 100 % of test pressure while raising the temperature to the maximum.
- b) Hold for a duration of 1 hour minimum at test pressure.
- c) Reduce the temperature to the minimum while maintaining 50 % to 100 % of test pressure.
- d) Hold for a minimum duration of 1 hour at test pressure.
- e) Raise the temperature to ambient temperature while maintaining 50 % to 100 % of test pressure.
- f) Release the pressure, then raise the temperature to the maximum.
- g) Apply the test pressure to the body shell, hold for a minimum duration of 1 hour, and then release the pressure.
- h) Reduce the temperature to the minimum.

- i) Apply the test pressure to the body shell, hold for a minimum duration of 1 hour, then release the pressure.
- j) Raise the temperature to ambient temperature.

## **F.25 Gas Body Test at Ambient Temperature**

### **F.25.1 General**

Gas shell testing at ambient temperature shall be conducted using the methodology indicated in I.8.2.

### **F.25.2 Leak Detection**

Gas testing at ambient temperature shall be conducted with a method for leak detection.

NOTE 1 The product may be completely submerged in a liquid, or the product may be flooded in the seal areas being validated, such that all possible leak paths are covered.

NOTE 2 The product may be assembled with one end of a tube connected to a blind connector enclosing all possible leak paths being validated.

When one end of the tube is connected to a blind connector, the other end of the tube shall be immersed in a liquid or attached to a leakage measurement device.

NOTE 3 Other methods that can detect leakage accurately are acceptable.

### **F.25.3 Acceptance Criteria**

Acceptance criteria shall be per I.8.2.2.

## **F.26 High-pressure Gas Seat Test at Ambient Temperature**

Valves shall undergo a seat test that conforms to I.8.3.

Leakage for soft-seated valves shall not exceed ISO 5208, Rate B.

Leakage for lubricated plug valves shall not exceed ISO 5208, Rate A.

For metal-seated valves, the leakage rate shall not exceed ISO 5208, Rate D.

For metal-seated check valves, the leakage rate shall not exceed ISO 5208, Rate F.

Actual leakage shall be recorded for all seat tests.

## **F.27 Low-pressure Gas Seat Test at Ambient Temperature**

Valves shall undergo a seat test that conforms to I.9.

Leakage for soft-seated valves shall not exceed ISO 5208, Rate B.

Leakage for lubricated plug valves shall not exceed ISO 5208, Rate A.

For metal-seated valves, the leakage rate shall not exceed ISO 5208, Rate D.

For metal-seated check valves, the leakage rate shall not exceed ISO 5208, Rate F.

Actual leakage shall be recorded for all seat tests.

## **Annex G** (normative)

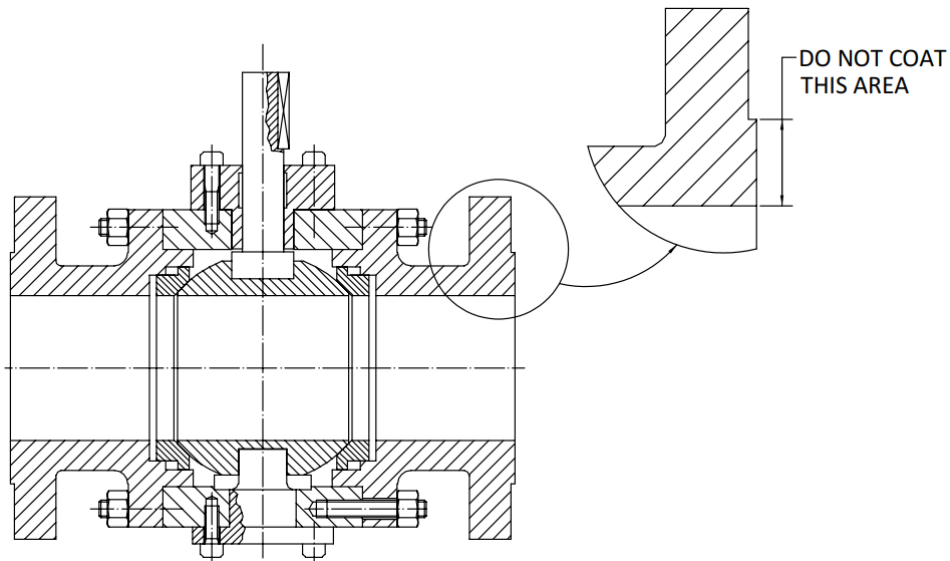
### **External Coating for End Connectors**

#### **G.1 General**

This annex provides coating requirements for flanges, weld end connectors, and pipe pups that shall be performed after all testing is complete.

#### **G.2 Uncoated Areas**

For valves with raised-face end connectors, the area identified in Figure G.1 shall remain uncoated.

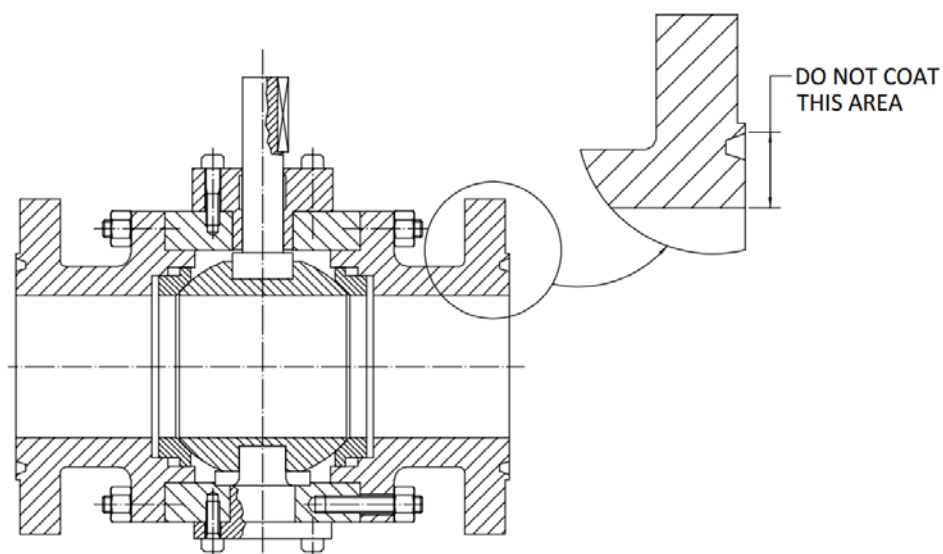


**Figure G.1—Raised Face**

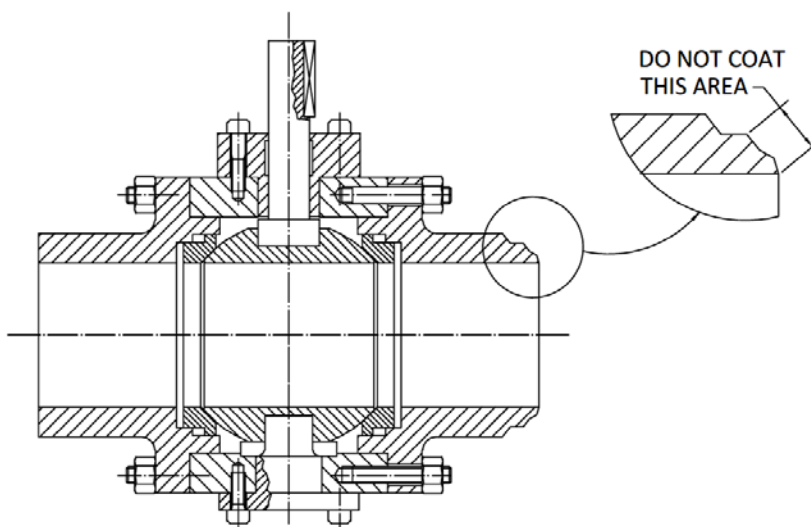
Valves with ring type joints or raised-face ring type joint end connectors shall have the area identified uncoated (see Figure G.2).

Valves with weld end connectors shall have the area identified uncoated (see Figure G.3).



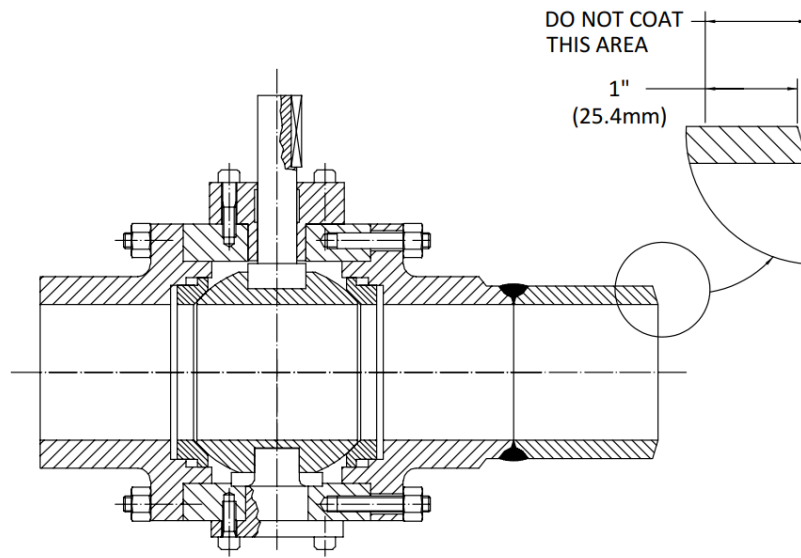


**Figure G.2—Ring Type Joint or Raised-face Ring Type Joint**



**Figure G.3—Weld End**

Valves with the pup pipe welded to end connectors shall have the area identified uncoated (see Figure G.4).



**Figure G.4—Pipe Pup Weld Ends**

## Annex H (normative)

### Heat-treat Equipment Qualification

#### H.1 Temperature Survey for Batch-type Furnaces

##### H.1.1 Method

The furnace working zone shall be defined by the manufacturer. A temperature survey within the furnace working zone(s) shall be performed on each furnace at the maximum and minimum temperatures for which each furnace is being used.

For furnaces with a working zone less than or equal to 10 ft<sup>3</sup> (0.3 m<sup>3</sup>), a minimum of three temperature sensors located either at the front, center, and rear, or at the top, center, and bottom of the furnace working zone shall be used.

For furnaces having a working zone greater than 10 ft<sup>3</sup> (0.3 m<sup>3</sup>) and not greater than 1125 ft<sup>3</sup> (31.8 m<sup>3</sup>), a minimum of nine temperature sensors shall be used. For each additional 125 ft<sup>3</sup> (3.5 m<sup>3</sup>) beyond 1125 ft<sup>3</sup> (31.8 m<sup>3</sup>) of furnace working zone surveyed, at least one additional temperature sensor shall be used, up to 40 temperature sensors. The first nine thermocouples shall be located as per Figure H.1 and Figure H.2. Each additional temperature sensor location shall be equally spaced in the central additional working zone volume.

NOTE Alternative recognized industry standards, such as SAE AMS 2750 or SAE AMS-H-6875, may be used if the furnace thermal uniformity survey (TUS) and furnace instrument calibration requirements in 6.8 are satisfied.

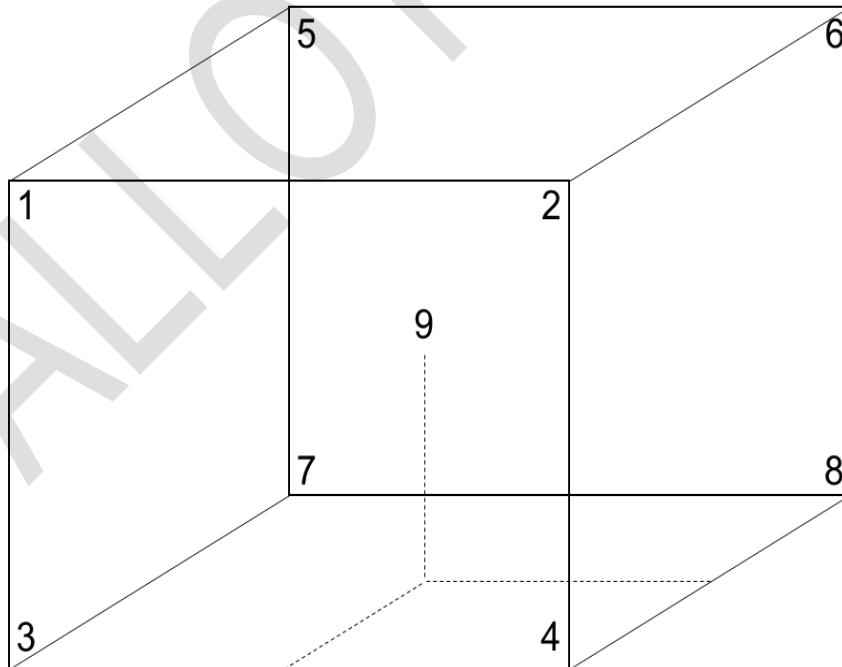
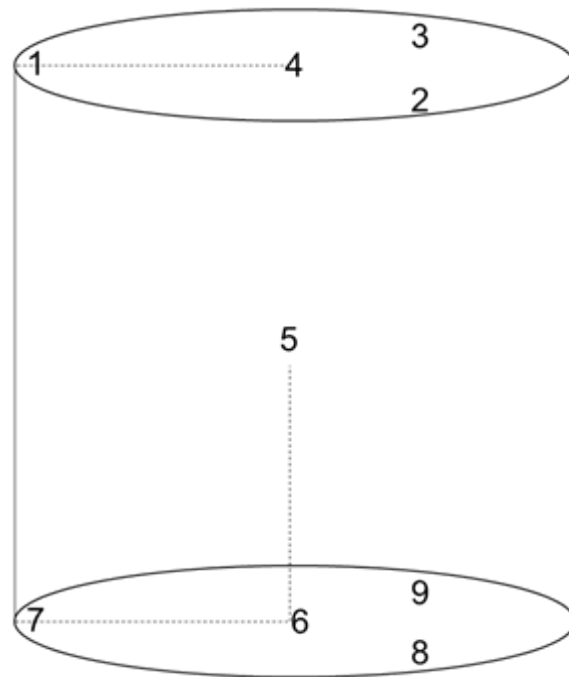


Figure H.1—Thermocouple Locations—Rectangular Furnace (Working Zone)



**Figure H.2—Thermocouple Locations—Cylindrical Furnace (Working Zone)**

After insertion of the temperature-sensing devices, readings shall be taken at least once every three minutes to determine when the temperature of the furnace working zone approaches the bottom of the temperature range being surveyed.

Once the furnace has reached the set-point temperature, the temperature of all test locations shall be recorded at two-minute intervals, maximum, for at least 10 minutes. Then, readings shall be taken at five-minute intervals, maximum, for enough time (at least 30 minutes) to determine the recurrent temperature pattern of the furnace working zone.

## H.1.2 Furnace Survey Temperature Tolerance

### H.1.2.1 Austenitizing, Normalizing, Annealing, or Solution Annealing Furnaces

The temperature at any point in the working zone of a furnace used for austenitizing, normalizing, annealing, or solution annealing shall not vary by more than  $\pm 25$  °F ( $\pm 14$  °C) from the furnace set-point temperature after the furnace working zone has been brought up to temperature. Before the furnace set-point temperature is reached, none of the temperature readings shall exceed the set-point temperature by more than the temperature tolerance.

### H.1.2.2 Tempering, Aging, or Stress-relieving Furnaces

Furnaces that are used for tempering, aging (sometimes called “precipitation hardening”), and/or stress-relieving shall not vary by more than  $\pm 15$  °F ( $\pm 8$  °C) from the furnace set-point temperature after the furnace working zone has been brought up to temperature. Before the furnace set-point temperature is reached, none of the temperature readings shall exceed the set-point temperature by more than the temperature tolerance.

## **H.2 Temperature Survey for Continuous-type Furnaces**

Furnaces used for continuous heat treatment shall be temperature surveyed in conformance with procedures specified in SAE AMS 2750 or SAE AMS-H-6875.

## **Annex I** **(normative)**

### **Quality Specification Level (QSL) and Supplemental Testing**

#### **I.1 General**

This annex shall apply to requirements for QSL in accordance with I.1 through I.4 and supplemental testing in I.5 through I.10, when QSL2, QSL3, QSL3G, QSL4, or QSL4G is specified. If any of the QSLs are specified, all requirements of a specific QSL shall apply.

NOTE 1 The QSLs increase in stringency of requirements with the QSL numbers 2, 3, 3G, 4, and 4G.

NOTE 2 In earlier editions of this specification, QSL1 was required to be applied to valves that conformed to the requirements of Sections 4–14 only. For this edition, reference to QSL1 has been removed entirely, and therefore is no longer a designation for valves, even for valves that only conform to the requirements of Sections 4–14.

This annex specifies the requirements for NDE, documentation, and pressure testing, and other supplemental requirements that shall be performed by the manufacturer if specified for a given QSL.

The results of testing or other requirements performed to satisfy requirements in Sections 4–14 shall also satisfy all or part of identical requirements of this annex.

If the valve was not previously tested, the QSL pressure testing and documentation requirements of this annex shall apply in lieu of the related requirements of Sections 4–14. When NDE is performed as part of Section 7 and Section 9, repeating of identical tests shall not be required per this annex.

#### **I.2 NDE Requirements for Quality Specification Levels**

The requirements of Table I.1 shall apply for NDE requirements for metallic parts for QSL2, QSL3/3G, and QSL4/4G.

NOTE 1 The requirements of Table I.1 vary by the type of raw material for the item being inspected.

The requirements of Table I.2 shall apply to the extent, method, and acceptance criteria for the various inspection codes used in Table I.1.

NDE personnel shall be qualified in conformance with the manufacturer's documented training program that is based on the requirements specified in ASNT SNT-TC-1A or ISO 9712.

NOTE 2 Certification under ASNT ACCP-CP-1A can satisfy this requirement.

A qualified Level III examiner that conforms to the requirements of ASNT SNT-TC-1A or ISO 9712 shall approve all NDE procedures.

NDE personnel qualified to Level II or Level III shall perform all NDE inspections.

NOTE 3 For guidance on qualification of nondestructive examination (NDE) service providers, see API 20D.

**Table I.1—NDE Requirements**

NOTE See Table I.2 for specification of the examinations referred to in this table.

Part	QSL2		QSL3/3G		QSL4/4G	
	Cast	Wrought <sup>g</sup>	Cast	Wrought <sup>g</sup>	Cast	Wrought <sup>g</sup>
Body or end connectors or bonnet or cover or gland housing <sup>f</sup>	VT1	VT2	VT1	VT2	VT1	VT2
	MT2 or PT2	MT1 or PT1	MT2 or PT2	MT1 or PT1	MT2 or PT2	MT1 or PT1
	—	—	RT1 <sup>a</sup>	UT2	RT3 or UT4	UT2
Weld ends <sup>b,f</sup>	MT2 or PT2	MT1 or PT1	MT2 or PT2	MT1 or PT1	MT2 or PT2	MT1 or PT1
	RT3 or UT4	UT2	RT3 or UT4	UT2	RT3 or UT4	UT2
Stem or shaft <sup>c</sup>	—	VT5	—	MT1 or PT1	—	MT1 or PT1
	—	—	—	—	—	UT2
Trunnion <sup>d</sup> or Trunnion/bearing plates	VT1 and VT5	VT2 and VT5	VT1	VT2	VT1	—
	—	—	MT2 or PT2	MT1 or PT1	MT2 or PT2	MT1 or PT1
	—	—	—	—	UT1	UT2
Pressure-boundary bolting	—	—	—	Table I.3	—	Table I.3
Closure member <sup>c</sup> Seat rings <sup>c</sup>	VT1 and VT5	VT2 and VT5	VT1	VT2	VT1	-
	—	—	MT2 or PT2	MT1 or PT1	MT2 or PT2	MT1 or PT1
Corrosion-resistant overlay in final supplied condition	VT3	VT3	VT3	VT3	VT3	VT3
	PT1	PT1	PT1	PT1	PT1	PT1
	—	—	—	—	UT3	UT3
Welds <sup>e</sup> to pressure-containing parts	VT3	VT3	VT3	VT3	VT3	VT3
	—	—	MT1 or PT1	MT1 or PT1	MT1 or PT1	MT1 or PT1
Hard facing	VT4	VT4	PT1	PT1	PT1	PT1
Sealing surfaces	—	—	MT3 or PT3	MT3 or PT3	MT3 or PT3	MT3 or PT3
Seals gaskets and seat springs	VT4					
Pressure-containing welds	VT3 and MT1 or PT1 and RT2 or UT3					
Plating	VT4					

<sup>a</sup> RT1 may be replaced by UT4 by agreement.

<sup>b</sup> A band around each weld end extending back from the body end a distance equal to the greater of 3tm or 2.75 in. (70 mm). See ASME B16.34 for verification of wall thickness "tm".

<sup>c</sup> MT or PT to be performed prior to coating, plating, or overlay.

<sup>d</sup> Trunnion designs may be pressure-containing or pressure-controlling. If the trunnion is a pressure-containing part, the requirements for body apply.

<sup>e</sup> These include fillet, attachment, reinforcing, stiffening welds, etc.

<sup>f</sup> RT1 plus UT1 may be replaced by RT3.

<sup>g</sup> Wrought material applies to bar, forgings, and plate.

**Table I.2—Extent, Method, and Acceptance Criteria of NDE/Item Examination Code**

NOTE See Table I.1 for application of the examinations referred to in this table.

Exam	Extent	Method	Acceptance
RT1	Critical areas per ASME B16.34 or as defined by manufacturer	ASME BPVC, Section V, Article 2	ASME BPVC, Section VIII, Division 1, Appendix 7
RT2	100 % where practicable	ASME BPVC, Section V, Article 2	ASME BPVC, Section VIII, Division 1, UW-51 for linear indications and ASME BPVC, Section VIII, Division 1, Appendix 4 for rounded indications
RT3	100 %	ASME BPVC, Section V, Article 2	ASME BPVC, Section VIII, Division 1, Appendix 7
UT1	Remaining areas not covered by RT1	ASME BPVC, Section V, Article 5	ASTM A609/A609M, Table 2, Quality Level 2
UT2	All surfaces	ASME BPVC, Section V, Article 5	Forgings: ASME BPVC, Section VIII, Div. 1, UF-55 for angle beam and ASME B16.34 for straight beam Plate: ASTM A578/A578M
UT3	Weldments: all surfaces	ASME BPVC, Section V, Article 4	ASME BPVC, Section VIII, Division 1, Appendix 12
	Overlay: all accessible machined surfaces	ASME BPVC, Section V, Article 4 straight beam method	ASTM A578A/A578M standard Level C
UT4	100 %	ASME BPVC, Section V, Article 5	ASTM A609/A609M, Table 2, Quality Level 1
MT1	All accessible surfaces	ASME BPVC, Section V, Article 7	ASME BPVC, Section VIII, Division 1, Appendix 6
MT2	All accessible surfaces	ASME BPVC, Section V, Article 7	ASME BPVC, Section VIII, Division 1, Appendix 7
MT3	All sealing surfaces	ASME BPVC, Section V, Article 7	No relevant rounded or relevant linear indications in pressure-contact sealing surfaces shall be permitted <sup>a</sup>
PT1	All accessible surfaces	ASME BPVC, Section V, Article 6	ASME BPVC, Section VIII, Division 1, Appendix 8
PT2	All accessible surfaces	ASME BPVC, Section V, Article 6	ASME BPVC, Section VIII, Division 1, Appendix 7
PT3	All sealing surfaces	ASME BPVC, Section V, Article 6	No relevant rounded or relevant linear indications in pressure-contact sealing surfaces shall be permitted <sup>a</sup>
VT1	100 % accessible as cast surfaces	9.4.2	9.4.2
VT2	100 % accessible as forged surfaces	9.4.3	9.4.3
VT3	100 % accessible as welded surfaces	7.5.3.2 or 7.8 or 7.9	7.5.3.2 or 7.8 or 7.9
VT4	100 % accessible surfaces	Per manufacturer requirements	Per manufacturer requirements
VT5	100 % accessible machined surfaces	9.4.4	9.4.4

<sup>a</sup> A relevant indication is defined as a surface NDE indication with major dimensions greater than  $1/16$  in. (1.6 mm). An indication not associated with a surface rupture is not considered to be a relevant indication.



### I.3 Production Material Requirements

Production material requirements shall conform to Table I.3 for the specified QSLs and the use of the following:

- API 20A for castings;
- API 20B for open die shaped forgings;
- API 20C for closed-die forging;
- API 20E for alloy and carbon steel bolting or API 20F for corrosion-resistant bolting when the specified bolting materials are listed therein;
- The manufacturer’s documented material specification, design code listed in 5.1, and Section 5 of API 20E for alloy and carbon steel bolting or API 20F for corrosion-resistant bolting when the specified bolting materials are not listed in API 20E or API 20F, respectively.

NOTE 1 Use of materials or services that conform to API 20A, API 20B, API 20C, API 20E, or API 20F does not require the material or service to be provided by a facility that is specifically licensed to API 20A, API 20B, API 20C, API 20E, or API 20F, respectively.

NOTE 2 Use of materials or services that conform to API 20A, API 20B, API 20C, API 20E, or API 20F includes identification of resulting products in accordance with the specified marking requirements of the API standard used.

**Table I.3—Production Materials Requirements**

Level	Applicable Reference	Applicable BSL-CSL-FSL
<b>QSL 2</b>	Section 6 Section 8.1	N/A (see 8.1 for details)
<b>QSL3/3G</b>	API 20A	CSL 2
	API 20B	FSL 2
	API 20C	FSL 2
	API 20E <sup>a,b, c</sup>	BSL 2
	API 20F <sup>a,b, c</sup>	BSL 2
<b>QSL4/4G</b>	API 20A	CSL 3
	API 20B	FSL 3
	API 20C	FSL3
	API 20E <sup>a,b, c</sup>	BSL 3
	API 20F <sup>a,b, c</sup>	BSL 3
<b>FOOTNOTES</b> <sup>a</sup> When materials listed in API 20E or API 20F are used, the bolts shall conform fully to the BSL and be marked in accordance with API 20E or API 20F. <sup>b</sup> When non-listed materials are used, requirements per BSL level in Section 5 of API 20E or Section 5 of API 20F shall apply. <sup>c</sup> Bolts used from materials not listed in the API 20E or API 20F bolting specification cannot be marked 20E or 20F.		

### I.4 Testing Requirements

Testing for QSL2, QSL3, QSL3G, QSL4, and QSL4G shall conform to the sequence shown in Table I.4.

**Table I.4—Testing Sequence for Quality Specification Levels**

Sequence	Test Activity	QSL2	QSL3 <sup>a, b</sup>	QSL3G <sup>a, b</sup>	QSL4 <sup>a, b, c</sup>	QSL4G <sup>a, b, c</sup>
1	Hydrostatic backseat (if provided) test per 10.2	One test	One test	One test	One test	One test
2	Hydrostatic shell test per 10.3 or I.5	One test	Two tests	Two tests	Three tests	Three tests
3	Torque or thrust test per I.6	N/R	All	All	All	All
4	Hydrostatic seat test per 10.4 or I.5	One test	Two tests	N/R <sup>d</sup>	Three tests	N/R <sup>d</sup>
5	Seat cavity relief test per I.7	1 valve per lot <sup>e</sup>	All	All	All	All
6	High-pressure gas shell test per I.8.2	N/R	N/R	Two tests	N/R	Three tests
7	High-pressure gas seat test per I.8.3	N/R	N/R	Two tests	N/R	Three tests
8	Low-pressure gas seat test per I.9.1	One test	Two tests	Two tests	Three tests	Three tests

<sup>a</sup> For all QSL3, QSL3G, QSL4, and QSL4G shell tests: After each test, the pressure shall be reduced to zero.  
<sup>b</sup> For all QSL3, QSL3G, QSL4, and QSL4G seat tests: After each test, the pressure shall be reduced to zero and the valve closure member shall be moved off the seat and returned.  
<sup>c</sup> For all QSL4 and QSL4G tests, the second pressure test shall have an extended duration of four times (4x).  
<sup>d</sup> As per the manufacturer's requirement, a hydrostatic seat test per 10.4 may be performed.  
<sup>e</sup> One lot refers to valves of the same purchase order and design, manufactured in the same manufacturing location.

N/R = not required

## I.5 Hydrostatic Testing

By agreement, hydrostatic testing shall be performed at a pressure higher than that specified in 10.3 or 10.4.

When specified, hydrostatic testing shall be performed for a duration longer than that required by Table 9 or Table 10.

## I.6 Torque/Thrust Functional Testing

### I.6.1 Method

The maximum torque or thrust required to operate axial, ball, gate, or plug valves shall be measured at the pressure specified by the purchaser for the following valve operations:

- a) open-to-closed with the bore pressurized and
  - 1) the cavity at atmospheric pressure for valves with no pressure balance hole, for valves with an upstream seat; or
  - 2) cavity at test pressure for valves with pressure balance hole, or downstream seated valve;
- b) closed-to-open with both sides of the closure member pressurized and the cavity at atmospheric pressure, for valves with an upstream seat;
- c) closed-to-open with one side of the closure member pressurized and the cavity at atmospheric pressure for upstream seated valves and the cavity at upstream pressure for valves with a downstream seat;
- d) as in item c), but with the other side of the closure member pressurized;

- e) closed-to-open and open-to-closed without pressure.

Torque or thrust values shall be measured with seats free of sealant, except for valve designs that require sealant as the primary means of sealing (e.g., lubricated plug valves). When used for the assembly of pressure-controlling parts, the lubricant shall not exceed the viscosity range of SAE 10W motor oil or equivalent.

### **I.6.2 Measuring Device Calibration**

Calibration of torque/thrust-measuring devices shall be as follows:

- Torque/thrust measuring devices shall be accurate to within  $\pm 2.0\%$  of the full scale.
- Torque/thrust measuring devices shall be calibrated with a master device to at least three equidistant points of full scale (excluding zero and full scale as required points of calibration).

### **I.6.3 Acceptance Criteria**

The measured thrust or torque shall not exceed the design thrust or torque (see 5.3.2). The results shall be recorded.

## **I.7 Cavity Relief Testing**

### **I.7.1 General**

A cavity relief test shall be performed if the valve has one or more self-relieving seats or a relief system that connects the valve cavity to one side of the valve. The procedure used for the cavity relief test shall be documented.

Cavity relief testing shall be performed on all valves except for those valves designed to not trap pressure in the cavity.

Valves with cavity relief functionality shall be tested by one of the methods specified in I.7.2, I.7.3, or I.7.4.

### **I.7.2 Trunnion-mounted Ball Valves**

#### **I.7.2.1 Procedure 1—Self-relieving Seats**

The procedure for cavity-relief testing of trunnion-mounted ball valves with self-relieving seats shall be as follows:

- a) Fill the valve in the half-open position with hydrostatic test fluid and purge trapped air.
- b) Close the valve.
- c) Close the branch vents.
- d) Apply pressure to the valve cavity until one branch pressure starts to rise and the seat relieves the cavity pressure into the valve end; record this relief pressure and port location.

For valve types with two self-relieving seats, continue to increase the pressure to the cavity until the second branch pressure starts to rise and the second seat relieves; record the relief pressure of the second seat.

The valve shall relieve at a differential pressure no greater than 33 % of the valve pressure rating.

EXAMPLE 1      Class 150, 275 psi (19.0 bar): The maximum differential pressure relief is 90 psi (6.2 bar).

EXAMPLE 2 Class 2500, 6250 psi (430.9 bar): The maximum differential pressure relief is 2060 psi (142.1 bar).

Pressure-temperature ratings for class-rated valves shall conform to the applicable rating table for the appropriate material group in ASME B16.34 or per MSS SP-44 for material not listed in ASME B16.34.

### **I.7.2.2 Optional Procedure 2—One or More Self-relieving Seats**

The procedure for cavity-relief testing of trunnion-mounted ball valves with one or more self-relieving seats shall be as follows:

- a) Fill the valve in the half-open position with hydrostatic test fluid.
- b) Close the valve.
- c) Pressurize both sides of the valve and the valve cavity simultaneously, up to 1.0 times MAWP.
- d) Isolate both sides of the valve and the valve cavity from the pressure source.
- e) Slowly decrease pressure on one side while monitoring the valve cavity pressure. Record pressure on that side required to activate SPE seat seal relief (point at which the valve cavity pressure decreases).
- f) Repeat steps a) to d) for the other side if it has a self-relieving seat.

The valve shall relieve at a differential pressure no greater than 33 % of the valve pressure rating.

Pressure-temperature ratings for class-rated valves shall conform to the applicable rating table for the appropriate material group in ASME B16.34 per MSS SP-44 for material not listed in ASME B16.34.

### **I.7.2.3 Procedure 3—Relief System Connecting Valve Cavity to One Valve Side**

The procedure for cavity-relief testing of trunnion-mounted ball valves with a relief system that connects the valve cavity to one side of the valve shall be as follows:

- a) Fill the valve in the half-open position with hydrostatic test fluid and purge trapped air.
- b) Close the valve.
- c) Close the branch vents.
- d) Apply pressure to the valve cavity until one branch pressure starts to rise; record this relief pressure and port location.

The valve shall relieve at a differential pressure no greater than 33 % of the valve pressure rating.

EXAMPLE 1 Class 150, 275 psi (19.0 bar): The maximum differential pressure relief is 90 psi (6.2 bar).

EXAMPLE 2 Class 2500, 6250 psi (430.9 bar): The maximum differential pressure relief is 2060 psi (142.1 bar).

### **I.7.3 Through-conduit Slab Gate Valves with Self-relieving Seats**

NOTE 1 For downstream sealing through-conduit gate valves, a center cavity pressure port is required.

Slab gate valves with one or more self-relieving seats that are upstream and/or downstream shall internally relieve the excess cavity pressure.

The procedure for cavity-relief testing of through-conduit slab gate valves with internal-relieving seats shall be as follows:

- a) Fill the valve in the half-open position with hydrostatic test fluid and purge any trapped air.
- b) Close the valve (see NOTE 2).

NOTE 2 For through-conduit gate valves with rising stem hydrostatic test fluid, volume may need to be adjusted during the closing stroke.

- c) Close both branch vents.
- d) Apply MAWP (or other pressure agreed with the purchaser) via one of the valve branches, with the opposite branch vented to atmosphere.
- e) Apply pressure to the valve cavity until the pressure in the pressurized branch starts to rise and the seat relieves the cavity pressure into the valve end; record this relief pressure.

The valve shall relieve at a differential pressure no greater than 33 % of the valve pressure rating.

#### **I.7.4 Floating Ball Valves**

##### **I.7.4.1 Procedure 1**

NOTE This procedure requires a test port in the valve body to have access to body cavity.

The test shall be performed with a hydrostatic test fluid.

The procedure shall be as follows:

- a) Fill the valve in the half-open position with hydrostatic test fluid and purge trapped air.
- b) Close the valve.
- c) Apply pressure to the valve cavity until one branch pressure starts to release and the seat relieves the cavity pressure into the valve end; record this relief pressure and port location.

The valve shall relieve at a differential pressure no greater than 33 % of the valve pressure rating.

##### **I.7.4.2 Procedure 2**

NOTE This procedure does not require a test port in the valve body.

The test shall be performed with nitrogen.

The procedure shall be as follows:

- a) With the valve in half-open position, pressurize the valve to the valve pressure rating plus the maximum theoretical cavity relief pressure.
- b) Isolate the valve from the pressure source.
- c) Close the ball.
- d) Vent each end to atmospheric pressure.

- e) Close each end of the valve.
- f) Open the valve to the half-open position for the release of trapped pressure in the body cavity.
- g) Monitor the release pressure into the valve bore (only one pressure gauge can be used and installed).

Acceptance criteria shall be as follows:

- Acceptance criteria of the release pressure shall be defined and calculated considering variation of initial pressure at volume of the valve body cavity (closed position) and final pressure at volume (volume of whole valve body + volume of the isolated test rig portion).
- Monitored release pressure above the calculated criteria shall be cause for rejection.

## I.8 High-pressure Gas Testing

### I.8.1 Valve Preparation for Testing

The valve shall be drained of hydrostatic test fluid and the inner parts shall be fully purged with air prior to the start of the high-pressure gas testing.

### I.8.2 High-pressure Gas Shell Test

#### I.8.2.1 Method

**Warning—High-pressure gas testing involves potential hazards. Safety precautions must be taken.**

All gas shell tests specified shall be performed with the valve unseated and partially open, and may be performed with the valve fully open, provided the body cavity is simultaneously filled and pressurized through a cavity connection. Test methods used shall be one of the following:

- Method 1: Valves shall have a high-pressure gas shell test performed using air or nitrogen, with the valve submerged in a water bath during testing.
- Method 2: Valves shall have a high-pressure gas shell test performed using nitrogen, with a minimum of 1 % helium tracer measured using a mass spectrometer.

The minimum test pressure shall be 1.1 times the pressure rating determined in conformance with 4.3 for the material at 100 °F (38 °C).

The test duration shall conform to Table I.5.

**Table I.5—Minimum Duration of Gas Shell Tests**

Valve Size		Test Duration (minutes)
NPS	DN	
≤ 18	≤ 450	15
20 and larger	500 and larger	30

#### I.8.2.2 Acceptance Criteria

Acceptance criteria shall satisfy one of the following:

- Method 1: When the valve is tested by submerged method, no visible leakage shall be permitted.

- Method 2: When using a mass spectrometer, a maximum of 0.27 cc/min of nitrogen + helium gas mixture per 1 % of helium shall be permitted when measured at each mechanical joint.

EXAMPLE For 1 % helium gas mixture, the allowable leakage is 0.27 cc/min. For 3 % helium gas mixture, the allowable leakage is 0.81 cc/min. For 10 % helium gas mixture, the allowable leakage is 2.7 cc/min.

### **I.8.3 High-pressure Gas Seat Test**

#### **I.8.3.1 Method**

Valves shall have a high-pressure gas seat test performed using inert gas (such as nitrogen, helium, etc.) as the test medium. The minimum test pressure shall be 1.1 times the pressure rating determined in conformance with 4.3 for the material at 100 °F (38 °C).

The test duration shall conform to Table 10.

#### **I.8.3.2 Acceptance Criteria**

Leakage for soft-seated valves and lubricated plug valves shall not exceed ISO 5208; Rate A (no visible leakage).

For metal-seated valves, except check valves, the leakage rate shall not be more than two times ISO 5208, Rate C.

For metal-seated check valves, the leakage rate shall not exceed ISO 5208, Rate E.

## **I.9 Low-pressure Gas Seat Testing**

### **I.9.1 Low-pressure Gas Seat Testing—Type II**

The seat shall be tested as specified in 10.4 at a test pressure between 80 psi and 100 psi (5.5 bar and 6.9 bar) using air or nitrogen as the test medium. The valve shall be drained of hydrostatic test fluid and the inner parts shall be fully purged with air prior to the start of the low-pressure gas testing. Pressure shall be identified as stabilized when the rate of change is no more than 5 % of the test pressure within 5 minutes.

#### **I.9.2 Acceptance Criteria**

The acceptable leakage rate for low-pressure gas seat testing shall be:

- ISO 5208, Rate A (no visible leakage) for soft-seated valves and lubricated-plug valves;
- ISO 5208, two times Rate C for metal-seated valves, except metal-seated check valves;
- ISO 5208, Rate E for metal-seated check valves.

## **I.10 Documentation**

The manufacturer shall maintain documentation as specified in Table I.6 for equipment that satisfies QSL2, QSL3/3G, and QSL4/4G.

**Table I.6—Documentation Requirements for Each QSL**

Item	Documentation	QSL2	QSL3/3G	QSL4/4G
1	Certificate of conformance to this annex and QSL	X	X	X
2	Pressure test report (including pressure, test duration, test medium, and acceptance criteria) used on pressure test	X	X	X
3	Calibration certificates on pressure test equipment used (e.g., pressure gauges, transducers, and chart recorders)	N/R	X	X
4	Heat-treatment records on all pressure-containing and pressure-controlling parts, including times and temperatures, e.g., charts	N/R	X	X
5	Material test reports on all pressure-containing and pressure-controlling parts	X	X	X
6	For sour service valves, certificate of conformance to NACE MR0175/ISO 15156	X	X	X
7	General arrangement drawings	X	X	X
8	NDE records	X	X	X
9	Cross-sectional assembly drawings with parts list and materials list, including design code for pressure-containing parts and pressure-boundary bolting	X	X	X
10	Installation, operation, and maintenance instructions/manuals	X	X	X
X = required documentation to be maintained by the manufacturer N/R = not required				



## **Annex J** (informative)

### **Requirements for Extended Hydrostatic Shell Test Duration and Records Retention for Valves in Jurisdictional Pipeline Systems**

#### **J.1 General**

This annex specifies the requirements for extended hydrostatic shell testing that shall be performed by the manufacturer if specified by the purchaser. This annex also specifies the test records to be provided to the purchaser and record retention requirements.

#### **J.2 Hydrostatic Shell Testing Requirements**

##### **J.2.1 General**

The hydrostatic shell test shall conform to 10.3 with test duration of at least 4 hours.

##### **J.2.2 Test Record Requirements**

Test records shall contain the following at a minimum and be provided to the purchaser.

- a) Name of the manufacturer, name of the organization that performs testing (if other than the valve manufacturer), identification of the individual responsible for performing the test, date, time, and location of test.
- b) Serial number, size, class, and end connector.
- c) Test medium (fluid) used.
- d) Beginning, ending, and actual test pressure and temperature readings, unless otherwise agreed.
- e) Test duration.
- f) A chart recording or digital record of the pressure showing the raise from zero to pressure at the beginning of the test and return to zero at the end.
- g) Any significant variations in pressure or temperature for the specific test.
- h) Any leaks or failures and their disposition.
- i) Certificates of calibration for all instrumentations used in the test, such as pressure transducers, pressure gauges, temperature devices, and chart recorders.

##### **J.2.3 Minimum Requirements for Pressure Transducers, Pressure Gauges, Temperature Devices, and Chart Recorders**

Calibration of pressure transducers, pressure gauges, temperature devices, and chart recorders shall conform to 9.1, but at an interval not greater than 12 months.

**J.2.4 Record Retention Requirement**

Test records in J.2.2 shall be provided to the purchaser and maintained by the manufacturer in conformance with Section 14.

## **Annex K** (normative)

### **Purchaser-specified Customization—Permissible Deviations to Specified Design and Manufacturing Requirements**

#### **K.1 General**

This annex identifies permissible deviations to specified design and manufacturing requirements allowing for customized valves conforming to this document, when specified by the purchaser.

#### **K.2 Intermediate Pressures and Temperature Ratings**

When intermediate pressures and temperature ratings that do not conform to 4.3.1 are required, the pressure-temperature rating may be determined using an industry-accepted design standard as per 5.1.

Valves with ASME flanged ends shall not be designed to an intermediate rating due to the risk of the valve being transferred to a different application, which may use the full flange rating.

When the purchaser specifies an intermediate pressure rating, the valve shall be marked with the agreed intermediate pressure rating on the body and nameplate (see Table 11 and Table 13).

Valves with an intermediate pressure-temperature rating shall have a bore size by agreement.

NOTE Conformance to Table 1 is not required.

The nameplate shall be marked with the agreed bore size.

#### **K.3 Valve Bore**

##### **K.3.1 Nominal Size**

When specified by the purchaser, a valve bore size not identified in Table 1 (see 4.4.1) shall be permitted.

##### **K.3.2 Non-standard Opening and Reduced-opening Valves**

When specified by the purchaser, non-standard opening or reduced-opening valve sizes that do not conform to 4.4.3 or 4.4.4 shall be permitted.

#### **K.4 Non-standard Face-to-face and End-to-end Dimensions**

When specified by the purchaser, face-to-face and end-to-end dimensions that are not shown or do not conform to 5.2.1 shall be permitted.

#### **K.5 End Connectors**

When specified by the purchaser, end connectors that do not conform to 5.2.3.1.1 shall be permitted.

When specified by the purchaser, weld end connectors that do not conform to 5.2.3.2 shall be permitted.

When specified by the purchaser, any other end connector that does not conform to 5.2.3 shall be permitted.

EXAMPLE Clamp, compact flange, hub, swivel, special weld ends, etc.

## **K.6 Flange Bolting for Studded-outlet End Connectors**

When specified by the purchaser, bolting for studded-outlet end connectors in metric dimensions shall be permitted.

When specified by the purchaser, valve end flanges shall be provided with tapped holes for engaging flange bolting.

Tapped bolt hole sizes shall be equal to bolt sizes used for the flange.

## **K.7 Other Drain Connectors**

When specified by the purchaser, other sizes in accordance with 5.6.1 shall be permitted.

Plugs, fittings, and blinds shall have a MAWP not less than the valve rated pressure and shall be capable of withstanding the valve hydrostatic shell test pressure (150 % of valve rated pressure).

Flange connections shall be supplied, complete with a blind flange, gasket, and bolting installed and pressure tested.

Flange, gasket, and bolting connection pressure-temperature ratings shall be the same as for the valve.

For studded flange connections, the thread depth in the valve body shall be a minimum of one stud diameter.

For flange connections, engagement of the threaded part shall comply with industry-accepted code or standard requirements.

Gaskets shall meet the requirements of ASME B16.20.

## **K.8 Lifting**

When specified by the purchaser, any design, manufacturing, and/or certification requirements for lifting points that do not conform to 5.9 shall be permitted.

When specified by the purchaser, lifting points on the valve shall not be required per 5.9.

When specified by the purchaser, valves shall be marked to indicate the SWL of each lifting point.

## **K.9 Chemical Composition**

When specified by the purchaser, the chemical composition of pressure-containing and pressure-controlling materials that do not conform to 6.3 shall be permitted.

## **K.10 Welding Overlay Iron Dilution**

When specified by the purchaser, an iron dilution Class Fe 5 (iron mass fraction 5.0 % maximum) shall be used as part of the CRA weld overlay with nickel-based alloy UNS N06625 as an alternative to 7.5.3.1.

### **K.11 Weld Repair of Forgings and Plate Material**

When specified by the purchaser, weld repair of forgings and plates shall be acceptable to correct material defects, in conformance with 7.11.3.

### **K.12 Use of Assembly Lubricant**

When specified, no lubricant shall be used on valves during assembly.

### **K.13 Hydrostatic Shell Testing of One-piece Bodies**

Hydrostatic shell testing shall be performed in the non-assembled condition for one-piece bodies with no body penetrations if specified.

### **K.14 Alternate Seat Test**

When specified by the purchaser, performing a high-pressure gas seat test conforming to I.8.3 as an alternative to the hydrostatic seat test of 10.4 shall be permitted.

### **K.15 Method of Operation**

When specified by the purchaser, manual gearbox output torque/thrust of at least 1.5 times the maximum required operating torque/thrust shall be based on a temperature other than the minimum temperature specified.

## **Annex L** (informative)

### **Specified Customization—Supplemental Options to Specified Design and Manufacturing Requirements**

#### **L.1 General**

This annex specifies supplemental requirements that shall be performed by the manufacturer when specified by the purchaser.

#### **L.2 Reduced-opening Valves with Circular Openings**

Reduced-opening valve sizes less than NPS 4 (DN 100) or greater than NPS 24 (DN 600) shall be specified.

#### **L.3 Valve Operational Data**

The maximum pressure differential (MPD) at which the valve is required to be opened shall be specified if different from the design parameters specified by the manufacturer.

The manufacturer shall provide the following data to the purchaser, when requested:

- a) flow coefficient  $C_v$  or  $K_v$ ;

NOTE  $K_v$  is related to the flow coefficient  $C_v$ , expressed in USC units of U.S. gallons of water per minute at 60 °F (15.6 °C), resulting in a 1 psi pressure drop as given by Equation (2):

$$K_v = C_v / 1.156 \quad (2)$$

- b) valve top works dimensions;
- c) break-to-open torque or thrust (BTO);
- d) break-to-close torque or thrust (BTC);
- e) run-to-open torque or thrust (RTO);
- f) run-to-close (reseat) torque or thrust (RTC);
- g) end-to-open torque or thrust (ETO);
- h) end-to-close (reseat) torque or thrust (ETC);
- i) valve drive train MAST;
- j) valve characteristics:
  - length and direction of stroke to open and close for linear valves; or

- angle and direction of rotation for part-turn or check valves; or
  - direction of rotation and number of turns for multi-turn valves;
- k) thrust necessary to enable the valve to maintain position, if applicable;
- l) valve breakaway angle or breakaway percent of stroke;

NOTE The breakaway angle or percent of stroke can be significant to actuator sizing when more than 5° or 5 %, respectively.

- m) number of turns for manually operated valves.

Corrosion-protection measures for long-term storage or unusual/harsh conditions shall be provided if specified by the purchaser.

#### **L.4 Extended Stem and Shaft Assemblies**

A valve with an extended stem shall be specified. Extended stems and shaft assembly service shall conform to 5.3 and 5.4.5. Extended stem and shaft assemblies shall be protected by an extension casing (housing).

#### **L.5 Antistatic Testing**

When specified, antistatic testing shall be performed.

The electrical resistance shall be tested with a power source not exceeding 12 V to have continuity between the parts listed in 5.8 when tested on a dry valve before pressure testing.

#### **L.6 Service Compatibility**

When specified, metallic and nonmetallic parts exposed directly to the pipeline fluid and lubricants shall be compatible with the commissioning fluids and service. Metallic material parts shall be selected to have a galling threshold stress above the design compressive load.

Qualification testing of elastomers and thermoplastics shall be performed in accordance with one of the following.

- NORSOK M-710; or
- ISO 23936 Parts 1 and 2; or
- a purchaser-agreed specification.

#### **L.7 Bolting for Sour Service**

When specified, the use of bolting for buried or insulated application shall conform to NACE MR0175/ISO 15156 per 6.6.

#### **L.8 NDE of Weld End Connector**

When specified, weld end connectors shall be subjected to surface and/or volumetric NDE.

Volumetric NDE examination of weld end connectors shall be performed for a minimum length equal to 1.5 times the mating pipe wall thickness or 2 in. (50 mm), whichever is greater, using one of the following:

- Radiographic testing on weld end connectors of castings shall conform to ASME B16.34, Appendix I. Acceptance shall conform to ASME B16.34, Appendix I.
- Ultrasonic testing on weld end connectors of castings shall conform to ASME B16.34, Appendix IV. Acceptance shall conform to ASME B16.34, Appendix IV.
- Ultrasonic testing on weld end connectors of forgings and plates shall conform to ASME B16.34, Appendix IV. Acceptance shall conform to ASME B16.34, Appendix IV.

Surface NDE shall be performed on the machined ends of the valve-weld bevel using one of the following:

- Magnetic particle testing on weld bevels of weld ends after machining shall conform to ASME BPVC, Section V, Article 7. Acceptance shall conform to ASME BPVC, Section VIII, Division 1, Appendix 6.
- Penetrant testing on weld bevels of weld ends after machining shall conform to ASME BPVC, Section V, Article 6. Acceptance shall conform to ASME BPVC, Section VIII, Division 1, Appendix 8.

### **L.9 Double Block and Bleed (DBB) Valves**

When specified, double block and bleed (DBB) valves shall undergo additional testing. The testing shall be performed as follows:

- With the valve unseated and partially open, the valve and its cavity shall be filled with test fluid.
- The valve shall then be closed, and the valve body vent valve opened to allow excess test fluid to overflow from the valve-cavity test connection.
- The test pressure shall be applied simultaneously from both valve ends.
- Seat tightness shall be monitored via overflow through the valve cavity connection.
- Acceptance criteria shall be per the requirements of 10.4.1, except that for the metal-to-metal seat test, the leakage rate shall not be more than two times ISO 5208, Rate C.

Requirements of L.9 shall be performed by the manufacturer and shall not be outsourced.

### **L.10 Double Isolation and Bleed DIB-1 (Both Seats Bidirectional)**

When specified, each seat in a double isolation and bleed (DIB-1) valve shall be tested in both directions. The testing shall be performed as follows:

- Cavity-relief valves shall be removed, if fitted.
- The valve and cavity shall be filled with test fluid, with the valve unseated and partially open, until the test fluid overflows through the cavity-relief connectors.
- To test for seat leakage in the direction of the cavity, the valve shall be closed.
- The test pressure shall be applied successively to each valve end to test each seat separately from the upstream side. Leakage shall be monitored via the valve cavity pressure-relief connectors.
- Thereafter, each seat shall be tested as a downstream seat. Both ends of the valve shall have the ends open to atmosphere and the valve cavity filled with test fluid.
- Pressure shall then be applied while monitoring leakage through each seat at both ends of the valve.



NOTE Some valve types (e.g., slab gate valves) can require the balancing of the upstream and valve cavity pressure during the downstream seat test, in which case only one end of the valve shall be open to atmosphere.

- Acceptance criteria shall be per the requirements of 10.4.1, except that for the metal-to-metal seat test, the leakage rate shall not be more than two times ISO 5208, Rate C.

Requirements of L.10 shall be performed by the manufacturer and shall not be outsourced.

### **L.11 Double Isolation and Bleed DIB-2 (One Unidirectional and One Bidirectional Seat)**

When specified, the bidirectional seat in a double isolation and bleed (DIB-2) valve shall be tested in both directions. The testing shall be performed as follows:

- Cavity-relief valves shall be removed, if fitted.
- The valve and cavity shall be filled with test fluid, with the valve unseated and partially half-open, until the test fluid overflows through the cavity-relief connectors.
- To test for seat leakage in the direction of the cavity, the valve shall be closed.
- The test pressure shall be applied successively to each valve end to test each seat separately from the upstream side. Leakage shall be monitored via the valve cavity pressure-relief connectors.
- To test the bidirectional seat from the cavity test, pressure shall be applied simultaneously to the valve cavity and upstream end. Monitor leakage at the downstream end of the valve.
- Acceptance criteria shall be per the requirements of 10.4.1, except that for the metal-to-metal seat test, the leakage rate shall not be more than two times ISO 5208, Rate C.

Requirements of L.11 shall be performed by the manufacturer and shall not be outsourced.

### **L.12 Operations Testing—Valves Required for Double Isolation and Bleed (DIB-1 or DIB-2)**

When specified, valves required for double isolation and bleed (DIB) operations shall be tested. The testing shall be performed as follows:

- a) Test fluid shall be hydrostatic test fluid that conforms to 10.1.2 or nitrogen gas, as specified.
- b) The following steps shall be performed. For DIB-1 valves, follow steps 1 through 9. For DIB-2 valves, follow steps 1 through 8.
  - 1) With the valve partly open, fill the valve with test medium and pressurize to valve MAWP.
  - 2) Close the valve.
  - 3) Reduce pressure on the downstream side of the valve to zero and monitor cavity pressure.
  - 4) Monitor leakage between the cavity and downstream side.
  - 5) Reduce pressure in the cavity to zero and monitor upstream pressure and monitor leakage to the downstream side.

NOTE For steps 5, 6, and 7, the pressure changes are done at a rate that minimizes the likelihood of rapid seat movement.

- 6) Reintroduce pressure into the cavity up to 145 psi (10 bar) and monitor leakage to the downstream side.
  - 7) Reduce pressure in the cavity to zero and monitor leakage to the downstream side.
  - 8) With the cavity and downstream side vented to zero, measure upstream seat performance by monitoring leakage at the cavity port.
  - 9) Repeat steps 1 through 8 on the opposite side of the valve.
- c) Leakage for soft-seated valves shall not exceed ISO 5208, Rate A (no visible detectable leakage for the duration of the test at test pressure).
- d) For metal-seated valves, the leakage rate shall not exceed ISO 5208, Rate C; however, for valves tested with gas, the leakage rate shall not exceed ISO 5208, Rate D.

Requirements of L.12 shall be performed by the manufacturer and shall not be outsourced.

### **L.13 External Coating or Painting of Corrosion-resistant Valves**

When specified, corrosion-resistant valves shall have an external coating or paint system applied.

### **L.14 Drive Train Strength Test**

When specified, the drive train strength test for axial, ball, gate, or plug valves shall be performed and the results recorded. The test torque shall be the greater of:

- two times the manufacturer's predicted breakaway torque/thrust; or
- two times the measured breakaway torque/thrust.

The test torque shall be applied with the closure member blocked for a minimum time of 1 minute.

NOTE For gate valves, the thrust can be tensile or compressive, whichever is the most stringent condition.

The test shall not cause any permanent visible deformation of the drive train.

For ball and plug valves, the total torsional deflection of the extended drive train when delivering the design torque shall not exceed the overlap contact angle between the seat and closure member.

### **L.15 Drain, Vent, and Injection Lines**

When specified, valves shall be provided with drain, vent, or injection lines. When provided, drain, vent, and injection lines shall be composed of rigid pipework. For valves with extended stems, the lines shall be fastened to the valve and/or extensions.

When provided, drain and vent lines shall:

- have a MAWP not less than the rated pressure of the valve on which they are installed;
- be capable of withstanding the hydrostatic shell test pressure of the valve;

- be designed in conformance with an industry-accepted design code;
- be suitable for blow-down operation, if applicable.

When provided, injection lines shall be rated to the same criteria as injection fittings in 5.6.

The manufacturer shall recommend the maximum injection pressure for the system.

The size of the injection lines and the termination location for all lines shall be by agreement.

## **L.16 Drain, Vent, and Injection Valves**

When specified, valves shall be provided with drain, vent, or injection valves. When provided, the drain and block valves shall have a rated pressure not less than the valve on which they are installed and be suitable for blow-down operation. Block and non-return valves fitted to injection lines shall be rated for the greater of the piping valve rated pressure and the injection pressure defined in 5.6.

## **L.17 Corrosion-resistant Metallic Surfaces**

When specified, corrosion-resistant metallic surfaces shall be required on lip seal or V-packing sealing surfaces.

## **L.18 Hardness Testing—Production Parts for Sour Service**

When specified, a production material hardness test on all metallic pressure-containing and pressure-controlling parts for sour service shall be required. The maximum hardness shall be per NACE MR0175/ISO 15156 requirements.

The method of hardness testing shall be performed in accordance with the following:

- For HBW hardness measurements, testing shall be performed in accordance with ASTM E10 or ISO 6506-1.
- For HRC hardness measurements, testing shall be performed in accordance with ASTM E18 or ISO 6508-1.
- Portable hardness measurements shall be performed in accordance with ASTM E110.

Hardness testing shall not be performed on the sealing surfaces of finished machined parts.

Results of the production hardness testing shall be reported and records maintained (see 14.1).

NOTE This hardness test may be performed by the supplier on the material provided and reported on the material test report.

## **L.19 Low-pressure Gas Seat Testing**

### **L.19.1 Low-pressure Gas Seat Testing—Type I**

#### **L.19.1.1 Method**

When specified, the valve shall be seat tested as specified in 10.4 and repeated at a test pressure between 5 psi and 14.5 psi (0.34 barg and 1 bar), using air or nitrogen as the test medium.

The closure member and leakage measurement connection port shall be purged with air with the valve half open.

Following pressurization and prior to commencing seat leakage measurement, the valve shall be fully stabilized. The valve stabilization period shall not begin until the test pressure in the valve remains constant for at least 2 minutes.

During the stabilization period, the outlet port from where leakage is to be measured shall remain connected to the leak detection device (e.g., flow meter or water-filled bubble counter vessel) and shall be monitored for the duration.

The stabilization period duration shall not be less than as specified in Table L.1. The duration can be extended in case stabilization is not achieved.

**Table L.1—Stabilization Period Duration**

Nominal Pipe Size	Duration (minutes)
4 (DN 100) and below	5
6 (DN 150) to 10 (DN 250)	10
12 (DN 300) to 18 (DN 450)	15
20 (DN 500) and above	30

Following stabilization, the seat leakage test shall begin.

#### **L.19.1.2 Acceptance Criteria**

The acceptable leakage rate for low-pressure gas seat testing shall be:

- ISO 5208, Rate A (no visible leakage) for soft-seated valves and lubricated-plug valves;
- ISO 5208, two times Rate C for metal-seated valves, except metal-seated check valves;
- ISO 5208, Rate E for metal-seated check valves.

### **L.19.2 Low Pressure Gas Seat Testing—Type II**

#### **L.19.2.1 Method**

When specified, the valve shall be seat tested as specified in 10.4 and repeated at a test pressure between 80 psi and 100 psi (5.5 bar and 6.9 bar) using air or nitrogen as the test medium.

The valve shall be drained of hydrostatic test fluid and the inner parts shall be fully purged with air prior to the start of the low-pressure gas testing. Pressure shall be identified as stabilized when the rate of change is no more than 5 % of the test pressure within 5 minutes.

#### **L.19.2.2 Acceptance Criteria**

The acceptable leakage rate for low-pressure gas seat testing shall be:

- ISO 5208, Rate A (no visible leakage) for soft-seated valves and lubricated-plug valves;

- ISO 5208, two times Rate C for metal-seated valves, except metal-seated check valves;
- ISO 5208, Rate E for metal-seated check valves.

## L.20 High-pressure Gas Testing

### L.20.1 General

When specified, high-pressure gas testing shall be performed.

The valve shall be drained of hydrostatic test fluid and the inner parts shall be fully purged with air prior to the start of the high-pressure gas testing.

### L.20.2 High-pressure Gas Shell Test

#### L.20.2.1 Method

**Warning—High-pressure gas testing involves potential hazards. Safety precautions must be taken.**

All gas shell tests specified shall be performed with the valve unseated and partially open, and may be performed with the valve fully open, provided the body cavity is simultaneously filled and pressurized through a cavity connection. Test methods used shall be one of the following:

- Method 1: Valves shall have a high-pressure gas shell test performed using air or nitrogen, with the valve submerged in a water bath during testing.
- Method 2: Valves shall have a high-pressure gas shell test performed using nitrogen with a minimum of 1 % helium tracer measured using a mass spectrometer.

**NOTE** By agreement, when the appropriate safety precautions are taken, the high-pressure gas shell test may be performed in a test cell and not submerged in a water bath.

The minimum test pressure shall be 1.1 times the pressure rating determined in conformance with 4.3 for the material at 100 °F (38 °C).

The test duration shall conform to Table L.2.

**Table L.2—Minimum Duration of Gas Shell Tests**

Valve Size		Test Duration (minutes)
NPS	DN	
≤ 18	≤ 450	15
20 and larger	500 and larger	30

#### L.20.2.2 Acceptance Criteria

Acceptance criteria shall satisfy one of the following:

- Method 1: When the valve is tested by submerged method, no visible leakage shall be permitted.
- Method 2: When using a mass spectrometer, a maximum of 0.27 cc/min of nitrogen + helium gas mixture shall be permitted when measured at each mechanical joint.

EXAMPLE For 1 % helium gas mixture, the allowable leakage is 0.27 cc/min. For 3 % helium gas mixture, the allowable leakage is 0.81 cc/min. For 10 % helium gas mixture, the allowable leakage is 2.7 cc/min.

### **L.20.3 High-pressure Gas Seat Test**

#### **L.20.3.1 Method**

Valves shall have a high-pressure gas seat test performed using inert gas (such as nitrogen, helium, etc.) as the test medium. The minimum test pressure shall be 1.1 times the pressure rating determined in conformance with 4.3 for the material at 100 °F (38 °C).

The test duration shall conform to Table 10.

#### **L.20.3.2 Acceptance Criteria**

Leakage for soft-seated valves and lubricated plug valves shall not exceed ISO 5208, Rate A (no visible leakage).

For metal-seated valves, except check valves, the leakage rate shall not be more than two times ISO 5208, Rate C.

For metal-seated check valves, the leakage rate shall not exceed ISO 5208, Rate E.

### **L.21 Valve Orientation**

The required operating orientation of the valve shall be specified when other than stem-vertical, pipeline-horizontal. When the operating orientation has been specified, the manufacturer shall provide installation, operation, and maintenance instructions for the valve.

Pressure testing per Section 10 shall be performed on one valve at the specified orientation unless otherwise specified by the purchaser.

### **L.22 Disassembly/Maintenance Tools**

The manufacturer shall inform the purchaser when special (designed by the manufacturer) tools are required for disassembly or maintenance.

When specified, special tools shall be supplied with the valves. The manufacturer shall provide instructions for use of the special tools.

When specified, special tools shall be tested to demonstrate functionality.

### **L.23 Pressure Balance Hole**

When specified, the closure member in ball or gate valves shall be provided with or without a pressure balance hole; see 14.2.1.

NOTE 1 Typical locations of pressure balance holes are shown in Figure L.1 and Figure L.2.

NOTE 2 Plugging the hole in fouling service may increase the risk of not being able to start or complete the valve stroke when a small-sized operator is used. The absence of a pressure balance hole can allow the body cavity to be vented from the main pipe in the open position and restrict outflow of potential stem leakage or body leakage.

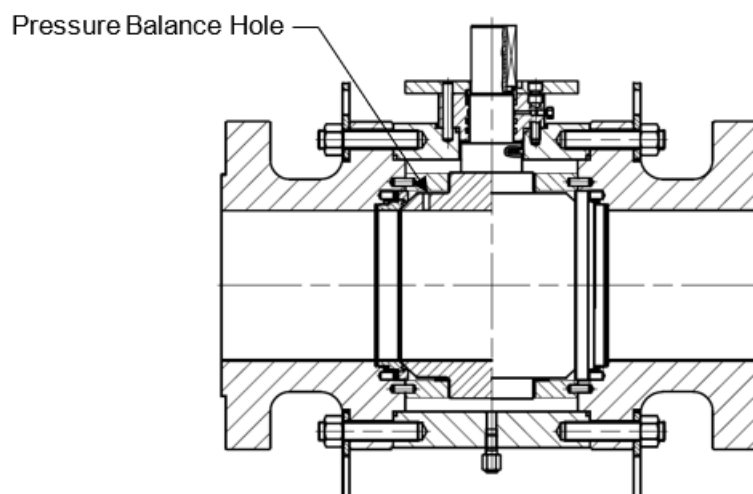


Figure L.1—Pressure Balance Hole for Ball Valve (Typical)

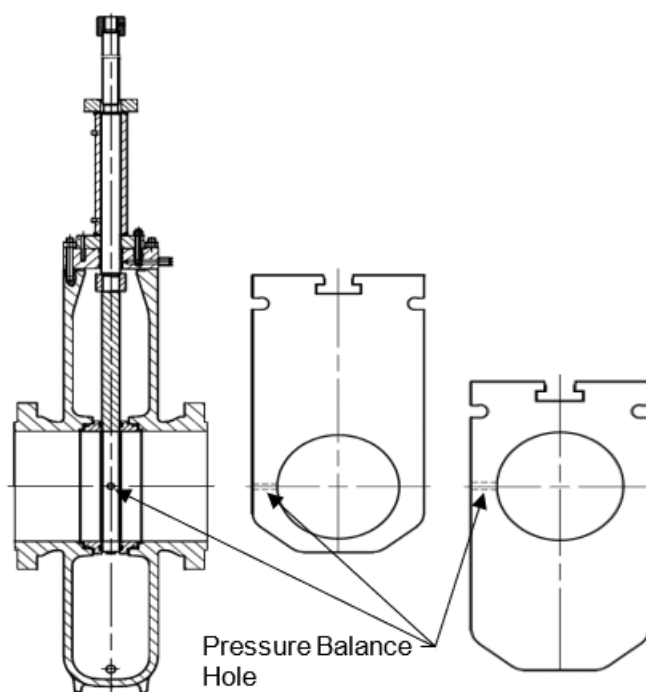


Figure L.2—Pressure Balance Hole for Gate Valve (Typical)

## L.24 Fugitive Emissions

### L.24.1 Valve Qualification Testing

When specified, valves shall undergo fugitive emission qualification testing. If specified, qualification testing of valves shall be performed in conformance to a national or international standard such as:

- API 624 for rising stem valves;
- API 641 for quarter-turn valves;

— ISO 15848-1 for Industrial valves .

NOTE Another methodology may be used to satisfy regulatory or contractual requirements.

### **L.24.2 Valve Production Testing**

When specified, valves shall be fugitive emission production tested.

The production fugitive emission testing of valves shall conform to ISO 15848-2.

NOTE Another methodology may be used to satisfy regulatory or contractual requirements.

### **L.25 Gauge/Drift Test**

When specified, gauge or drift testing of the valves shall be performed.

NOTE 1 Venturi or reduced-bore valves, and valve designs where any component obstructs the bore in the otherwise fully open position, are not suitable for most gauge/drift test operations.

NOTE 2 Certain full-opening valves with pockets can allow bypass of fluid around a short pipeline inspection gauge or sphere.

### **L.26 Locking Provision**

When specified, a provision for locking shall be provided for the valve. When specified, the locking feature for check valves shall be designed to lock the valve in the open position only. Locking features for other types of valves shall be designed to lock the valve in the open and/or closed position.

### **L.27 Fire Testing**

When specified, valves shall be qualified by fire testing. If specified, fire-tested valves shall be qualified by testing that conforms to any of the following standards:

- API 6FA;
- API 607;
- ISO 10497.

All ancillary components and valves (e.g., cavity relief) with soft gaskets or seals shall be qualified by fire testing, either separately or included in valve qualification.

NOTE Tests to API 607, 4<sup>th</sup> Edition, for soft seated valves up to Class 600 do not meet the current edition of API 607, since both the operational and external leakage tests were required to be carried out at only 29 psig (2 bar), compared to 75 % of the rated pressure for other procedures.

### **L.28 Pressure Testing Valves with Hydrostatic End Load**

When specified, valves shall be pressure tested with connectors that subject the valve to hydrostatic end load to the requirements of 10.2, 10.3, and 10.4.

NOTE Visible marks left on the sealing area by the test gasket are acceptable, provided the sealing integrity has been demonstrated.



## **L.29 External Loads**

When specified, the valve design shall accommodate the effects of external loads. The purchaser shall define the external loads. The manufacturer shall demonstrate, by calculation or test, that under loads resulting from MAWP and any defined pipe or external loads, distortion of the valve does not impair functionality or sealing.

EXAMPLE External loads can include piping, thermal, seismic, environmental, and installation.

## **Annex M** (informative)

### **Valves in Hydrogen (H<sub>2</sub>) Gas Service**

#### **M.1 General**

A valve designated for use in hydrogen gas (H<sub>2</sub>) service shall conform to both the applicable requirements from Section 4 through Section 14 and Annex M. Modifications or supplements to some of the requirements in Section 4 through Section 14 may be necessary for hydrogen service valves but shall be limited to those specified in Annex M only.

#### **M.2 Specification Level for Hydrogen**

The specification level for hydrogen (SLH) for valves for hydrogen service shall be specified. The requirements of Table M.1 shall apply to the specified SLH and shall be performed in the order of the sequence (A–D for validation and 1–5 for FAT) listed therein.

NOTE The following can influence the determination of the desired SLH:

- 1) location of valve (confined space, buried, open air, rural/remote);
- 2) percentage H<sub>2</sub> in gas;
- 3) chemical elements in gas that could impact materials;
- 4) design pressure;
- 5) cyclic pressure service.

**Table M.1—Summary of Specification Level Requirements for Hydrogen**

Item	Sequence	Requirement	SLH1	SLH2	SLH3	SLH4
1	—	Minimum QSL level	a	QSL2	QSL3G	QSL4G
2	—	Validation	5.10.4	5.10.4	M.3.3.4	M.3.3.4
3	A	Validation: High-pressure gas shell test	M.3.3.2	M.3.3.2	M.3.3.4	M.3.3.4
4	B	Validation: High-pressure gas seat test	M.3.3.3	M.3.3.3	M.3.3.4	M.3.3.4
5	C	Validation: Dynamic gas pressure test	N/R	M.3.3.5	M.3.3.4	M.3.3.4
6	D	Validation: Antistatic test	N/R	M.3.3.7	M.3.3.7	M.3.3.7
7	—	Validation: Fugitive emission test (ISO 15848-1)	N/R	M.3.3.6	M.3.3.6	M.3.3.6
8	—	Validation: Fire safe design	M.3.3.8	M.3.3.8	M.3.3.8	M.3.3.8
9	1	Supplemental Acceptance Testing: Antistatic test	M.8.6	M.8.6	M.8.6	M.8.6
10	2	Supplemental Acceptance Testing: Pressure tests with hydrostatic end load	N/R	N/R	N/R	M.8.5
11	3	Supplemental Acceptance Testing: High-pressure gas shell test	N/R	M.8.2	per QSL and M.8.2	per QSL and M.8.2
12	4	Supplemental Acceptance Testing: High-pressure gas seat test	N/R	M.8.3	per QSL and M.8.3	per QSL and M.8.3
13	5	Supplemental Acceptance Testing: Fugitive emissions production test	N/R	N/R	M.8.4	M.8.4
14	-	SLH marking (see M.9)	SLH1	SLH2	SLH3	SLH4
FOOTNOTES <sup>a</sup> For SLH1, the applicable quality requirements of Sections 4-14 apply. N/R = not required						

## M.3 Design

### M.3.1 Plug Valve Sealant/Lubricant

Lubricated plug valves shall be furnished with sealant/lubricant validated for the rated design temperature range of the valve in hydrogen service.

The sealant/lubricant shall be capable of maintaining viscosity for tight sealing and lubricity for ease of operation in hydrogen service.

### M.3.2 Body Penetrations

If specified, body penetrations (see 5.6), including ports provided for test purposes, shall be blocked by plug, weld, flange, or as otherwise specified.

If the body penetration is blocked and cavity venting is no longer possible, the valve shall not be marked DBB or DIB-1 or DIB-2.

### M.3.3 Design Validation

#### M.3.3.1 General

Design validation shall be performed as specified in Table M.1 for all valves conforming to Annex M.

NOTE Valve designs validated in conformance with Annex F may not satisfy the requirements of Table M.1. Additional validation may be required for those designs to qualify for conformance to Annex M.

#### M.3.3.2 High-pressure Gas Shell Test

For SLH1 and SLH2, a high-pressure gas shell test shall conform to I.8.2, with the following exceptions:

- a) Valves NPS 24 and smaller shall be tested with and satisfy the acceptance criteria of Method 1 only.
- b) Valves larger than NPS 24 shall be tested and satisfy the acceptance criteria of either Method 1 or Method 2.
- c) The test duration shall be two times the minimum duration that is specified in Table I.5.

#### M.3.3.3 High-pressure Gas Seat Test

For SLH1 and SLH2, a high-pressure gas seat test shall conform to I.8.3, with the following exceptions:

- a) The test duration shall be two times the minimum duration that is specified in Table 10.
- b) The acceptance criteria for metal-seated valves, except metal-seated check valves, shall not exceed ISO 5208 Rate C.
- c) The acceptance criteria for metal seated check valves shall not exceed five times ISO 5208 Rate D.

NOTE See I.8.3.2 for the acceptance criteria for other valve types not identified in M.3.3.3.

#### M.3.3.4 SLH3 and SLH4 Requirements

If SLH3 or SLH4 is specified, design validation shall be performed conforming to the requirements specified in Annex F, using nitrogen as the test medium, and with the following exceptions:

- a) Duration for tests shall be as follows:
  - 1) Body pressure tests as per F.17.1, F.21, and F.24.3: minimum of two hours.  
NOTE In F.24.3, the change to two hours applies to four different test stages.
  - 2) Body pressure tests as per F.25: two times the minimum duration of Table I.5.
  - 3) Seat tests as per F.17.2, F.22, and F.23: minimum of two hours.
  - 4) Seat tests as per F.26 and F.27: two times the minimum duration of Table 10.
- b) Acceptance criteria for seat test per F.17.2, F.22, and F.23 shall be in accordance with M.8.3.
- c) Acceptance criteria for seat test per F.26 and F.27 shall be as follows:
  - 1) For metal-seated valves, the leakage shall not exceed ISO 5208, five times Rate C.

- 2) For metal-seated check valves, the leakage shall not exceed ISO 5208, five times Rate E.

Actual leakage shall be recorded for all seat tests.

#### **M.3.3.5 Dynamic Pressure Test**

For SLH2, cycle testing shall be performed in conformance with F.19 followed by seat testing in conformance with F.26 and F.27. The test medium shall conform to F.7.

#### **M.3.3.6 Fugitive Emissions Test**

For valves with a potential external leak path to the environment and without an external stem or shaft, the fugitive emissions test shall:

- 1) include thermal cycles required by ISO 15848-1; and
- 2) not include the mechanical cycles required by ISO 15848-1.

For SLH2, valves with an external stem or shaft (e.g., ball valves, check valves with external shaft, gate valves, or plug valves) shall conform to ISO 15848-1, minimum tightness of Class CH, and endurance class CO1 for the design temperature range of the valve.

For SLH3, valves with an external stem or shaft (e.g., ball valves, check valves with external shaft, gate valves, or plug valves) shall conform to ISO 15848-1, minimum tightness of Class BH, and endurance class CO1 for the design temperature range of the valve.

For SLH4, valves with an external stem or shaft (e.g., ball valves, check valves with external shaft, gate valves, or plug valves) shall conform to ISO 15848-1, minimum tightness of Class AH, and endurance class CO1 for the design temperature range of the valve.

For valves with ancillary valves (e.g., vent valve, drain valve, relief valve), fugitive emissions testing shall be performed on the ancillary valve separately or shall be included in the valve's fugitive emissions testing.

For valves without external stem or shaft and with no external leak path to the environment (e.g., mono-block axial check valve), fugitive emissions testing shall not be required.

#### **M.3.3.7 Antistatic Test**

For SLH2, SLH3, and SLH4, antistatic testing shall conform to L.5.

#### **M.3.3.8 Fire Safe Design**

Valves shall be fire safe tested in conformance with L.27.

#### **M.3.3.9 Scaling**

The scaling per Annex F shall be permitted.

The scaling of fire tests and fugitive emission tests shall be permitted in conformance with the relevant fire test or fugitive emission test standard used.

#### **M.3.3.10 Revalidation of Gaskets/Seals**

A change in the material (including material grade), design or construction of the following seals; independent of the size, shall require revalidation to M.3.3.2 through M.3.3.6, as applicable:

- a) lip seal;
- b) v-pack/chevron type;
- c) delta seal;
- d) bellows seal;
- e) die formed graphite seal.

## **M.4 Materials**

### **M.4.1 Requirements for Metallic Materials**

#### **M.4.1.1 General**

The materials requirements shall conform to Annex M for a valve with a maximum allowable temperature up to 347 °F (175 °C). For valves requiring a maximum allowable temperature greater than 347 °F (175 °C), material requirements shall conform to Annex M and the additional requirements of API 941.

All metallic materials shall conform with one of the following:

- a) NACE MR0175/ISO 15156 materials groups, which are listed in M.4.1.2; or
- b) NACE MR0175/ISO 15156 and the requirements of M.4.1.3, including the results of performance testing required therein.

NOTE The material groups of Annex M are as defined by NACE MR0175/ISO 15156.

#### **M.4.1.2 Materials Permitted**

The following materials shall be permitted for pressure-containing parts, pressure-controlling parts, and drive train parts in hydrogen service:

- a) carbon steel per M.4.1.4; or
- b) low-alloy carbon steel; or
- c) austenitic stainless steel.

The following materials shall be permitted for pressure-controlling parts and drive train parts in hydrogen service:

- a) solution annealed or annealed nickel-based alloys; or
- b) precipitation hardened nickel-based alloys in conformance with API 6ACRA.

#### **M.4.1.3 Material Permitted with Additional Testing**

**CAUTION—Materials listed in M.4.1.3 may be susceptible to failure mechanisms under some service conditions. Use of materials for manufacture that are suitable for the intended service of the valve is critical.**

If materials are acceptable based on testing protocols and acceptance criteria as agreed between the manufacturer and the purchaser, materials permitted for pressure-containing parts in hydrogen service shall include but not be limited to the following:

- a) solution annealed or annealed nickel-based alloys;
- b) precipitation hardened nickel-based alloys in conformance to API 6ACRA.

NOTE Guidance on material testing in hydrogen service can be found in ASTM G142; NACE TM0198; ASTM G129; ASTM G148; ASME BPVC VIII, Division 3, Section KD-10; ASME B31.12; and/or NACE MR0175/ISO 15156.

#### **M.4.1.4 Carbon Steel**

In addition to weld ends, the chemical composition and carbon equivalent of carbon steel pressure-containing parts shall conform to 6.3.

#### **M.4.1.5 Springs**

Unless otherwise specified by the purchaser, materials used for springs shall be limited to the following alloy designations:

- a) UNS R30003; or
- b) UNS R30035.

If specified by the purchaser, the following materials shall be permitted:

- a) UNS N06625 (alloy 625) per API 6ACRA; or
- b) UNS N07718 (alloy 718) per API 6ACRA; or
- c) UNS N07750 (alloy X750).

### **M.4.2 Non-metallic Seals**

#### **M.4.2.1 General**

The requirements of M.4.2 shall apply to all non-metallic seals used in valves for hydrogen service.

#### **M.4.2.2 Rapid Gas Decompression**

Rapid gas decompression testing of elastomeric materials shall be performed in conformance with L.6, except that the testing medium shall be per the following:

- a) 100% hydrogen gas; or
- b) 100% CO<sub>2</sub>.

NOTE 1 Testing of elastomeric seals may be required using representative groove geometries at agreed test conditions.

NOTE 2 Optional blister resistance testing under high-pressure 100 % hydrogen gas for thermoplastics may be performed for applications with elevated pressures, and temperatures at the upper and lower limits of the material. Test conditions are typically representative of the valve application. Refer to API 17J and API 17B for guidance on blister resistance testing of thermoplastics.

#### **M.4.2.3 Compatibility/Aging**

Elastomeric seal material shall be tested using the procedures and acceptance criteria specified in ISO 23936-2, using 100 % hydrogen as the test gas, with minimum total test duration of 28 days.

A test temperature and test pressure shall be specified, based on the capabilities of the material and intended use.

Aging samples shall be taken at 2, 7, 14, and 28 days, and properties evaluated for acceptance.

Thermoplastic seal material shall be tested using the procedures and acceptance criteria described in ISO 23936-1, "Level 2 – Material Stability (short term)" using 100 % hydrogen as the test gas. Temperature classification per ISO 23936-2 shall be specified.

### **M.4.3 Surface Treatments—Plating, Coating, and Lining**

Use of a metallic coating (electroplated or electroless plated), HVOF, conversion coatings, plastic coating, and/or linings shall not be permitted to prevent hydrogen degradation of the base material or protect the base material from hydrogen exposure.

## **M.5 Welding**

### **M.5.1 General**

The following materials shall not be used for pressure-containing welds in hydrogen service:

- a) solid-solution nickel-based alloys; or
- b) precipitation hardened nickel-based alloys.

The hardness of weld metal and HAZ shall conform to NACE MR0175/ISO 15156.

For austenitic stainless steel, filler metal shall have a maximum carbon content of 0.03 % mass fraction.

### **M.5.2 Overlay and Cladding**

Use of overlay and cladding shall not be permitted for the purpose of prevention of hydrogen degradation of the base material or to protect the base material from hydrogen exposure.

After application of the overlay or cladding material, the base materials shall conform to NACE MR0175/ISO 15156.

### **M.5.3 Non-destructive Examination (NDE)**

For all pressure-containing welds, surface NDE shall be performed using one of the following methods:

- a) Magnetic particle testing on pressure-containing welds shall conform to ASME BPVC, Section V, Article 7, and acceptance shall conform to ASME BPVC, Section VIII, Division 1, Appendix 6.
- b) Penetrant testing on pressure-containing welds shall conform to ASME BPVC, Section V, Article 6, and acceptance shall conform to ASME BPVC, Section VIII, Division 1, Appendix 8.

For all pressure-containing welds, volumetric NDE examination shall be performed using one of the following methods:

- a) Radiographic testing on 100 % of the welds in accordance with ASME BPVC, Section V, Article 2, and acceptance shall conform to ASME BPVC, Section VIII, Division 1, UW-51 for linear indications, and ASME BPVC, Section VIII, Division 1, Appendix 4 for rounded indications.



- b) Ultrasonic testing on 100 % of the welds in accordance with ASME BPVC, Section V, Article 4, and acceptance shall conform to ASME BPVC, Section VIII, Division 1, Appendix 12.

## **M.6 Bolting**

All bolting (see 8.1 and 8.2) shall conform to NACE MR0175/ISO 15156.

Material for bolting shall be limited to one of the following:

- a) carbon steel; or
- b) low-alloy steel; or
- c) austenitic stainless steel; or
- d) precipitation hardened nickel-based alloys per API 6ACRA; or
- e) other materials per M.4.1.3.

## **M.7 Quality Control**

If SLH1 is specified, the applicable quality requirements of Section 4 through Section 14 shall apply.

If SLH2 is specified, QSL2 shall be applied at a minimum.

If SLH3 is specified, QSL3G shall be applied at a minimum.

If SLH4 is specified, QSL4G shall be applied.

## **M.8 Supplemental Acceptance Testing**

### **M.8.1 General**

Factory acceptance testing shall be performed in conformance with Table M.1.

NOTE Tests already completed in conformance with Section 10 are not required to be repeated per Table M.1.

### **M.8.2 High-pressure Gas Shell Test**

If required, a high-pressure gas shell test shall conform to I.8.2, with the following exceptions:

- a) Valves NPS 24 and smaller shall be tested with Method 1.
- b) Valves larger than NPS 24 shall be tested using Method 1 or Method 2 .
- c) The test duration shall be two times the minimum duration of Table I.5.

The sampling size for SLH2 shall be a minimum of one valve per type, per size, and per pressure class in the purchase order, and shall be randomly selected and tested.

### **M.8.3 High-pressure Gas Seat Test**

If required, a high-pressure gas seat test shall conform to I.8.3, with the following exceptions:

- a) The test duration shall be two times the minimum duration of Table 10.
- b) The leakage for metal-seated valves, except metal-seated check valves, shall not exceed ISO 5208 Rate C.
- c) The leakage for metal-seated check valves shall not exceed five times ISO 5208 Rate D.

The sampling size for SLH2 shall be a minimum of one valve per type, per size, and per pressure class in the purchase order, and shall be randomly selected and tested.

## **M.8.4 Fugitive Emission Production Testing**

### **M.8.4.1 Test Methods**

For SLH3 and SLH4, all valves shall be subjected to a fugitive emission production test that shall:

- a) conform to L.24.2 with acceptance criteria conforming to M.8.4.3; or
- b) be tested using the method of ISO 15848-2 performed using forming gas (5 % hydrogen/95 % nitrogen) as the test medium.

When testing with forming gas, the requirements of M.8.4.2 shall apply.

### **M.8.4.2 Alternative Method Using Forming Gas**

#### **M.8.4.2.1 General**

The test fluid for the fugitive emissions test shall be forming gas.

The test shall be conducted using the helium sniffing method per ISO 15848-1, except as modified in M.8.4.2.2.2.

At the beginning of each test, a calibrated leak, using forming gas, shall be measured to demonstrate that the sensitivity of the instrument is calibrated correctly.

#### **M.8.4.2.2 Test Equipment**

##### **M.8.4.2.2.1 General**

Fugitive emissions shall be measured with a mass spectrometer (see M.8.4.2.2.2) or with a hydrogen leak detector (see M.8.4.2.2.3).

Measuring equipment shall be capable of detecting a calibrated hydrogen leak in the magnitude of  $10^{-6}$  mbar-l/s.

##### **M.8.4.2.2.2 Mass Spectrometers**

Mass spectrometers shall have a nominal minimal sensitivity of  $1 \times 10^{-7}$  mbar-l/s for hydrogen in sniffer mode and be calibrated for use with hydrogen as the test medium.

Mass spectrometers shall:

- a) not be used in vacuum mode;
- b) not be used if the ratio between the maximum allowable leak rate and the hydrogen content measured in the atmosphere of the test area is smaller than 10;

c) be calibrated using an external calibrated leakage.

#### **M.8.4.2.2.3 Hydrogen Leak Detectors**

Hydrogen leak detectors shall have a nominal sensitivity of at least  $5 \times 10^{-7}$  mbar-l/s and be calibrated for use with forming gas as the test medium.

Quantification of leakages shall be performed by placing the tracer probe tip against the point of leakage until a stable reading is shown. This shall be repeated three times, where the highest measured value shall be documented as the test result. Tracer probes shall be removed from the testing surface and allowed to stabilize to a reading of zero (0) before repeating.

After connecting the detector probe to the instrument, the system shall be verified by passing the detector probe tip across the orifice of a calibrated leak. The probe tip shall be kept within 1/8 in. (3 mm) of the orifice of the calibrated leak. The speed of movement of the probe tip shall not exceed the speed at which the calibrated leak can be detected.

#### **M.8.4.2.3 Calibration**

Mass spectrometers and hydrogen leak detectors shall be calibrated the day of the test, prior to testing, and per the spectrometer or detector operation and maintenance manual, using a permeation type leak or a micro-capillary leak.

Calibration shall be performed prior to the first leakage measurement being performed and be repeated until it is accepted by the instrument.

The maximum deviation factor between current and previous calibrations shall be equal to or less than 1.1.

Mass spectrometer calibration shall be accepted only if the background and calibrated leak rate are stabilized as per the device manufacturer's specification.

If a micro-capillary leak detector is used, the setup shall:

- a) be free of leakage to the atmosphere;
- b) be flushed with the test medium to eliminate air from the setup;
- c) be allowed to stabilize under pressure for a period of 10 minutes before calibration;
- d) be measured using a calibrated pressure gauge or sensor;
- e) not contain any fluoropolymer material.

#### **M.8.4.3 Acceptance Criteria**

##### **M.8.4.3.1 General**

Depending on the test gas used, the acceptance criteria of M.8.4.3.2 or M.8.4.3.3 shall apply.

##### **M.8.4.3.2 Acceptance Criteria Helium**

Maximum leakage when testing with helium gas with a minimum purity of 97 % by volume shall be in accordance with Table M.2.

**Table M.2—Fugitive Emission Test Acceptance Criteria—Helium Gas<sup>a</sup>**

Emission Tightness Class	Allowable Leakage Rate Stem Seal <sup>b, d</sup>	Allowable Leakage Rate Body Seal <sup>c, d</sup>
	mbar-l/s per mm diameter	mbar-l/s per mm diameter
A <sup>e</sup>	$\leq 1.78 \times 10^{-7}$	$\leq 1.78 \times 10^{-8}$
B <sup>f</sup>	$\leq 1.78 \times 10^{-6}$	$\leq 1.78 \times 10^{-7}$

FOOTNOTES

<sup>a</sup> Helium gas shall have a minimum purity of 97 % by volume.

<sup>b</sup> For stem seals; diameter shall be the stem diameter in millimeters at the point of measurement.

<sup>c</sup> For body-to-bonnet or body-to-cover seals; mm diameter shall be the outer diameter of the gasket in millimeters at the point of measurement. For non-circular gaskets, the equivalent diameter shall be taken as the perimeter divided by (pi).

<sup>d</sup> To be measured with helium tracer gas in mbar-l/s per mm diameter using the sniffer technique.

<sup>e</sup> Due to the constraints of the sniffer technique, for stem seal diameters equal or smaller than 12 mm, the maximum leakage shall be  $2.1 \times 10^{-6}$  mbar-l/s, and for body seal diameters equal or smaller than 120 mm, the maximum leakage shall be  $2.1 \times 10^{-6}$  mbar-l/s.

<sup>f</sup> Due to the constraints of the sniffer technique, for stem seal diameters equal or smaller than 2 mm, the maximum leakage shall be  $2.0 \times 10^{-6}$  mbar-l/s, and body seal diameters equal or smaller than 12 mm, the maximum leakage shall be  $2.1 \times 10^{-6}$  mbar-l/s.

**M.8.4.3.3 Acceptance Criteria Forming Gas**

Maximum leakage when testing with forming gas shall be in accordance with Table M.3.

**Table M.3—Fugitive Emission Test Acceptance Criteria—Forming Gas**

Emission Tightness Class	Allowable leakage rate stem seal <sup>a, c</sup>	Allowable leakage rate body seal <sup>b, c</sup>
	mbar-l/s per mm diameter	mbar-l/s per mm diameter
A <sup>d</sup>	$\leq 5.93 \times 10^{-8}$	$\leq 5.93 \times 10^{-9}$
B <sup>e</sup>	$\leq 5.93 \times 10^{-7}$	$\leq 5.93 \times 10^{-8}$

FOOTNOTES

<sup>a</sup> For stem seals; diameter shall be the stem diameter in millimeters at the point of measurement.

<sup>b</sup> For body-to-bonnet or body-to-cover seals; diameter shall be the outer diameter of the gasket in millimeters at the point of measurement. For non-circular gaskets, the equivalent diameter shall be taken as the perimeter divided by (pi).

<sup>c</sup> To be measured with forming gas tracer gas in mbar-l/s per mm diameter.

<sup>d</sup> Due to the constraints of the sniffer technique, for stem seal diameters equal to or smaller than 34 mm, the maximum leakage shall be  $2.1 \times 10^{-6}$  mbar-l/s, and for body seal diameters equal or smaller than 340 mm, the maximum leakage shall be  $2.1 \times 10^{-6}$  mbar-l/s.

<sup>e</sup> Due to the constraints of the sniffer technique, for stem seal diameters equal or smaller than 4 mm, the maximum leakage shall be  $2.4 \times 10^{-6}$  mbar-l/s, and for body seal diameters equal or smaller than 40 mm, the maximum leakage shall be  $2.1 \times 10^{-6}$  mbar-l/s.

**M.8.5 Pressure Testing Valves with Hydrostatic End Load**

For SLH4, the valve shall be pressure tested with connectors that subject the valve to hydrostatic end loads in conformance with L.28.

### **M.8.6 Antistatic Test**

The valve shall undergo antistatic testing in conformance with L.5 to validate the criteria specified in 5.8.

### **M.9 Marking**

The valve nameplate shall identify the SLH (see M.2) in addition to the applicable QSL and other marking required by Section 4 through Section 14 in conformance with the requirements of Section 12.

### **M.10 Minimum Documentation and Retention**

In addition to the requirements of Section 14, the following documents shall be maintained by the manufacturer for a minimum of 10 years following the date of manufacture (see 3.1.12):

- a) certificate of conformance to NACE MR0175/ISO 15156 for applicable metallic materials and welds;
- b) statement of conformance to fugitive emissions certificate as per ISO 15848-1;
- c) documented evidence of compliance with local directives and regulations (e.g., including but not limited to PED, ATEX, ASME, CRN certification) when applicable to the specific design;
- d) fire safe certificate;
- e) RGD certificate for non-metallic materials;
- f) compatibility/aging certificate of non-metallic materials;
- g) statement of conformance to antistatic requirements;
- h) validation records;
- i) certificates and/or material test records for material permitted with additional testing (see M.4.1.3);
- j) fugitive emissions production test report.

NOTE Purchaser or regulatory requirements can specify additional records or a longer record retention period.

*This document is not an API Standard; it is under consideration within an API technical committee but has not received all approvals required to become an API Standard. It shall not be reproduced or circulated or quoted, in whole or in part, outside of API committee activities except with the approval of the Chairman of the committee having jurisdiction and staff of the API Standards Dept. Copyright API. All rights reserved.*

## Bibliography

- [1] ASNT ACCP-CP-1, ASNT Central Certification Program
- [2] API Specification Q1, *Specification for Quality Management System Requirements for Manufacturing Organizations for the Petroleum and Natural Gas Industry*
- [3] API Specification 6FD, *Specification for Fire Test for Check Valves*
- [4] API Specification 17D, *Specification for Subsea Wellhead and Tree Equipment*
- [5] API Standard 20D, *Qualification of Nondestructive Examination Services for Equipment Used in the Petroleum and Natural Gas Industry*
- [6] API Standard 20G, *Qualification of Suppliers of Welding Services for Use in the Petroleum and Natural Gas Industry*
- [7] API Standard 20H, *Heat Treatment Services-Batch Type for Equipment Used in the Petroleum and Natural Gas Industry*
- [8] API Standard 20J, *Qualification of Distributors of Metallic Materials for Use in the Petroleum and Natural Gas Industry*
- [9] API Standard 20L, *Qualification of Polymeric Seal Manufacturers for Use in the Petroleum and Natural Gas Industry*
- [10] API Standard 20M, *Qualification of Suppliers of Machining Services for Use in the Petroleum and Natural Gas Industry*
- [11] API Standard 20N, *Heat Treatment Services –Continuous Line for Equipment Used in the Petroleum and Natural Gas Industry*
- [12] API Standard 600, *Steel Gate Valves—Flanged and Butt-welding Ends, Bolted Bonnets*
- [13] API Technical Report 21TR1, *Selection for Bolting Materials*
- [14] ASTM E8, *Standard Test Methods for Tension Testing of Metallic Materials*
- [15] ASTM E29, *Standard Practice for Using Significant Digits in Test Data to Determine Conformance with Specifications*
- [16] ASTM A577, *Standard Specification for Ultrasonic Angle-Beam Examination of Steel Plates*
- [17] ASME BTH-1, *Design of Below-the-Hook Lifting Devices*
- [18] EN 12516-1, *Industrial valves—Shell design strength—Part 1: Tabulation method for steel valve shells*
- [19] EN 12516-2, *Industrial valves—Shell design strength—Part 2: Calculation method for steel valve shells*
- [20] EN 13445-3, *Unfired pressure vessels—Part 1: General*

- 
- [21] EN 13445-3, *Unfired pressure vessels—Part 3: Design*
- [22] ISO 5210, *Industrial valves—Multi-turn valve actuator attachments*
- [23] ISO 5211, *Industrial valves—Part-turn actuator attachments*
- [24] ISO 6892-1, *Metallic materials—Tensile testing—Part 1: Method of test at room temperature*
- [25] ISO 9001, *Quality management systems—Requirements*
- [26] ISO 80000-1:2009, *Quantities and units—General principles*
- [27] MSS SP61, *Pressure Testing of Valves*
- [28] MSS SP101, *Part-Turn Valve Actuator Attachment—Flange and Driving Component Dimensions and Performance Characteristics*
- [29] MSS SP102, *Multi-Turn Valve Actuator Attachment—Flange and Driving Component Dimensions and Performance Characteristics*
- [30] ASME STP-PT-003, *Hydrogen Standardization Interim Report for Tanks, Piping, and Pipelines*
- [31] Trautmann, Anton, et al. "Hydrogen Embrittlement of steels in High pressure H<sub>2</sub> Gas and Acidified H<sub>2</sub>S Saturated Aqueous Brine Solution"
- [32] ASM International, *Corrosion in the Petrochemical Industry*, 2nd Edition (Section 17.8.2.6, Hydrogen embrittlement)
- [33] CEN/TR 17797: 2022, *Gas infrastructure – Consequences of hydrogen in the gas infrastructure and identification of related standardisation need in the scope of CEN/TC 234*
- [34] NASA/TM 2016-218602, *Hydrogen Embrittlement*
- [35] API RP 941, *Steels for Hydrogen Service at Elevated Temperatures and Pressures in Petroleum Refineries and Petrochemical Plants*
- [36] API 21TR1, *Materials Selection for Bolting*
- [37] ASME B31.12, *Hydrogen Piping and Pipelines*
- [38] API 6J, *Testing of Oilfield Elastomers*
- [39] API 17B, *Recommended Practice for Flexible Pipe*